

RTX 600 /V DOMINO ZERO

Devices used to control remote counters and cold rooms with pulse electronic expansion valve management

User Manual

02/20

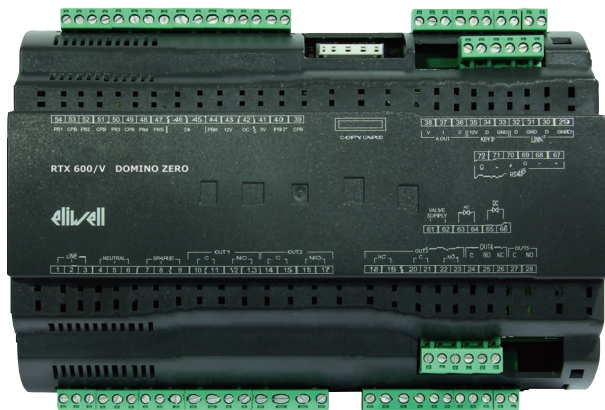

The information given in this document contains general descriptions and/or technical characteristics concerning the performance of the products found in it. This document is not intended to replace these products nor must it be used to determine their suitability and reliability for any users' specific applications. Each user or integrator is responsible for performing the risk analysis, evaluation and appropriate and complete testing of the products according to the specific application or use in question. Neither Schneider Electric, nor its sister companies nor subsidiaries shall be legally or financially liable for any potentially incorrect use of the information contained in this documentation. If you have any suggestions for improvement or modification, or find any errors in this publication, please contact us.

The user hereby accepts not to reproduce, other than for his/her own personal, non-commercial use, all or part of this document in any form without the written permission of Schneider Electric or Eliwell. The user also agrees to not create any hypertext links to this document or its content. Schneider Electric and Eliwell shall not grant any rights or license for personal and non-commercial use of the document and its content, with the exception of a non-exclusive license to consult it "as-is", at your own risk. All other rights are reserved.

The installation and use of this product must comply with all applicable state, regional and local safety regulations. For safety reasons and to ensure greater compliance with the data of the documented system, component repairs must be performed exclusively by the manufacturer.

When using devices for applications with technical safety requirements, comply with the relevant instructions. Failure to use Eliwell software or other approved software with our hardware products can result in injury, damage or incorrect operating results.

Failure to comply with this information can result in injury or damage to the equipment.

© 2020 Eliwell. All rights reserved.



Safety information	7
Important information	7
Information about...	9
Introduction	9
Overview of the range	12
Introduction	13
Box contents	13
Models	14
List of valves	14
Accessories	15
Main features	16
Main components	18
Preliminary configurations	19
Introduction	20
Available applications	21
Application AP1	22
Application AP2	23
Application AP3	24
Application AP4	25
Application AP5	26
Application AP6	27
Application AP7	28
Application AP8	29
Mechanical installation	30
Before starting	31
Power supply disconnection	31
Considerations concerning programming	31
Operating environment	32
Comments concerning installation	32
Installation	33
Electrical connections	35
Best wiring practices	36
Wiring guidelines	37
Serial connections	42
Connectors	43
Wiring diagrams	45
Technical characteristics	49
Introduction	50
Environmental and electrical characteristics	50
Input characteristics	51
Output characteristics	52
Serial ports	52
Power supply	53
Auxiliary EEV power supply	53
User interface and operation	54

KDEPlus Terminal	55
KDWPlus Terminal	56
KDT Terminal (Vertical and Horizontal)	57
KDX Terminal	59
Device connection with terminal and/or viewer	61
Using the device	63
"Machine Status" Menu	66
`Programming" menu	67
Setting and calibrating the probes	68
Setting the displayed values	68
Tools	70
MFK (Multi Function Key)	71
UNICARD	71
Copy parameters (UNICARD/MFK)	72
Boot Loader Firmware	73
Terminal shared on Link2	73
Electronic Expansion Valve (EEV)	74
Introduction	75
List of valves	76
Valve type	77
Refrigerant type	78
Local pressure transducer (4..20 mA)	79
Local ratiometric transducer	79
Pressure/ratiometric transducer shared via Link2	80
Ratiometric transducer shared via hardware	81
Remote backup saturation probe	81
Overheating probe	81
Protection fuse	82
Valve regulation parameters	84
EEV driver description	85
Manual EEV management	86
EEV driver regulation	87
Local Network	89
Introduction	90
Supervision gateway	90
Temperature probe sharing	91
Synchronized Defrost	92
Simultaneous Defrost	93
Sequential Defrost	95
Display shared on Link2	97
Setpoint value sharing	97
Sharing commands	97
Defrost	98
Defrost/Dripping	99
Display and alarm operation	100
Automatic Defrost	101
Manual defrost	102

RTC Defrost	104
Electric heater defrost	106
Inversion defrost	108
Hot gas defrost for plug-in systems	110
Hot gas defrost for systems with remote group	111
Modulating electric heater defrost: Smart Defrost	112
Dual evaporator defrost	113
Regulators	114
Regulation	115
Evaporator Fans	121
Modulated Fans	127
Condenser Fans	130
Preheating	131
Energy Saving	132
Deep Cooling Cycle (DCC)	133
Auxiliary Output (AUX)	135
Auxiliary Output (Light)	136
Stand-by	137
Soft Start	138
Pump down (Pump out)	139
Compressor oil heater	140
Counter Cleaning Function	141
Practical examples	142
Floating suction for positive overheating ≥ 4 K)	143
Floating suction with low overheating (~ 0 K)	144
Diagnostics	146
Alarms and indications	147
Probe alarms	150
Minimum and maximum temperature alarm	151
Defrost ended due to timeout alarm	153
External alarm	154
Door open alarm	155
Parameters	156
Parametri utente RTX 600 /V	157
Parametri installatore RTX 600 /V	169
Modbus MSK 756 functions and resources	193
Setting parameters via Modbus	194
Modbus table content	195
Table of Modbus Parameters	197
Folder Visibility Table	297
Table of Modbus Resources	301



Important information

Notices

Read these instructions carefully and visually inspect the equipment to familiarize yourself with the device before attempting to install it and/or put it into operation, or before servicing it. The following warning messages may appear anywhere in this documentation or on the equipment to warn of potential dangers or to call attention to information that can clarify or simplify a procedure.



The addition of this symbol to a danger warning label indicates the existence of an electrical hazard that could result in personal injury should the user fail to follow the instructions.



This is the safety warning symbol. It is used to warn the user of the potential dangers of personal injury. Observe all the safety warnings that follow this symbol to avoid the risk of serious injury or death.

DANGER

DANGER indicates a dangerous situation which, if not avoided, **will result in** death or serious injury.

WARNING

WARNING indicates a dangerous situation which, if not avoided, **could result in** death or serious injury.

CAUTION

CAUTION indicates a potentially dangerous situation which, if not avoided, **could result in** minor or moderate injury.

NOTICE

NOTICE used in reference to procedures not associated with physical injuries.

Note

Electrical equipment must only be installed, used and repaired by qualified technicians. Schneider Electric and Eliwell do not accept any liability for any consequences arising from the use of this material. An authorized person is someone in possession of the skills and knowledge applicable to the structure, to the operation of the electrical equipment and to its installation, and who has received safety training in order to recognize and avoid the risks involved.

Personnel qualification

Only personnel with suitable training and an in-depth knowledge and understanding of the contents of this manual and any other documentation relevant to the product are authorized to work on and with this product. Qualified personnel must be capable of identifying any dangers which may arise from the parameterization or changing of parameter values, and from the use of mechanical, electric and electronic equipment in general. Plus, they must be familiar with the personal safety laws, provisions and regulations which must be observed during system planning and implementation.

Permitted use

This device is designed to control remote counters and cold rooms with pulse electronic expansion valve (EEV) in single or multiple evaporator configuration.

The device must be installed and used in accordance with the provided instructions and in particular, in normal conditions, dangerous energized parts must not be accessible.

The device should be suitably protected from water and dust. Access to the various product parts from the front should involve the use of a keyed or tooled locking mechanism.

The device is suited for integration into equipment for commercial use and/or similar for refrigeration purposes and has been verified on the basis of the harmonized European standards of reference.

Only use the product with the specified cables and accessories. Only use genuine accessories and spare parts.

Prohibited use

Any use other than that indicated in the above paragraph "Permitted use" is strictly prohibited.

The relay contacts supplied are electromechanical and are subject to wear. The functional safety protection devices, specified by international or local laws, must be installed outside this device.

Liability and residual risks

The liability of Schneider Electric and Eliwell is limited to the correct and professional use of the product according to the directives referred to herein and in the other supporting documents, and does not cover any damage (including but not limited to) the following causes:

- unspecified installation/use and, in particular, in contravention of the safety requirements of the legislation in force in the country of installation and/or specified in this document;
- use on equipment which does not provide adequate protection against electrocution, water and dust in the actual installation conditions;
- use on devices which allow access to dangerous parts without the aid of tools and/or which do not have a keyed locking mechanism;
- product tampering and/or alteration;
- installation/use on equipment that does not comply with the regulations in force in the country of installation.

Disposal



The equipment (or product) must be subjected to separate waste collection in compliance with local legislation regarding waste disposal.

Information about...

Introduction

Aim of the document

This document describes the devices **RTX 600 /V** used to control remote counters and cold rooms with pulse electronic expansion valve (EEV) management in single or multiple evaporator configuration, including information relating to installation and wiring.

Use this document to:

- Install and use your device
- Familiarize yourself with the functions of the device

Note: read this document and all related documents carefully before installing, operating or servicing the device.

Note regarding validity

The technical characteristics of the devices described in this manual are also available online, through the Eliwell website (www.eliwell.com).

The characteristics illustrated in this manual should be identical to those which can be found online. In accordance with our policy of continuous improvement, the content of the documentation may be revised from time to time in order to improve its clarity and accuracy. If there are any discrepancies between the manual and the information available online, use the latter as your point of reference.

Related documents

Publication title	Reference document code
Technical Sheet RTX 600 /V DOMINO ZERO	9IS24738 (EN-IT)

All available technical documentation and other technical information is available to download from the website: www.eliwell.com

Product related information

DANGER

RISK OF ELECTRIC SHOCK, EXPLOSION, FIRE OR ARC FLASH

- Disconnect all power from all equipment including connected devices prior to removing any covers or doors, or installing or removing any accessories, hardware, cables or wires except under the specific conditions specified in this user manual.
- Always use a properly rated voltage sensing device to confirm the power is off where and when indicated.
- Before restoring the power supply, replace and secure all covers, hardware components and cables.
- For all the devices requiring it, make sure there is an effective ground connection.
- Use only the specified voltage when operating this device and any associated products.
- Do not connect the device directly to the line voltage, unless expressly indicated.

Failure to follow these instructions will result in death or serious injury.

DANGER

LOOSE WIRING CAN RESULT IN ELECTRIC SHOCK AND/OR FIRE

- Tighten the connections in compliance with the technical specifications for torque values and make sure the wiring is correct.
- Do not insert more than one cable per terminal board connector unless you are using the ends of the cables (terminals).

Failure to follow these instructions will result in death or serious injury.

WARNING

LOSS OF CONTROL

- The system designer must consider the potential failure modes of the control circuit and, for some critical control functions, provide a means for reaching a safe condition during and after a circuit failure. Examples of critical control functions are the emergency stop and end of travel stop, power supply cut-off and restart.
- Separate or redundant control circuits must be provided for critical control functions.
- The system control circuits can include communication connections. Keep in mind the implications of transmission delays or sudden connection failures.
- Comply with all standards regarding accident prevention and local applicable safety directives.
- Every implementation of this equipment must be tested individually and completely in order to verify its proper operation before it is commissioned.

Failure to follow these instructions can result in death, serious injury, or equipment damage.

WARNING

UNINTENDED EQUIPMENT OPERATION

- Use appropriate safety interlocks where personnel and/or equipment hazards exist.
- Install and operate this equipment in an enclosure appropriately rated for its intended environment and secured by a keyed or tooled locking mechanism.
- Power line and output circuits must be wired and fused in compliance with local and national regulatory requirements for the rated current and voltage of the particular equipment.
- Do not use this equipment for safety-critical functions.
- Do not disassemble, repair, or modify this equipment.

Failure to follow these instructions can result in death, serious injury, or equipment damage.

⚠ WARNING

UNINTENDED EQUIPMENT OPERATION

- Use shielded wires for all analog I/O and communication signals.
- Ground the wire shields for all analog I/O and communication signals in a single point (1).
- The signal cables (probes, digital inputs, communication, and relative power supplies) must be laid separately from the device power cables.
- Reduce the length of the wires and cables as much as possible and avoid winding them around electrically connected parts.

Failure to follow these instructions can result in death, serious injury, or equipment damage.

(1) Grounding in several points is permitted if the connections are made to an equipotential ground surface that is sized to avoid damage to the cable shields in the event of a short circuit in the power supply.

When handling the equipment, take care to avoid damage caused by electrostatic discharge. In particular, the unshielded connectors are extremely vulnerable to electrostatic discharge.

⚠ WARNING

UNINTENDED EQUIPMENT OPERATION DUE TO ELECTROSTATIC DISCHARGE

- Keep the equipment in the protective packaging until ready for installation.
- The device must only be installed in type-approved cupboards and/or in points that prevent unauthorized access and provide protection from electrostatic discharge.
- When handling sensitive equipment, use a grounded device protecting against electrostatic discharge.
- Before handling the equipment, always discharge the static electricity from the body by touching an earthed surface or type-approved antistatic mat.

Failure to follow these instructions can result in death, serious injury, or equipment damage.

The procedure for loading one of the preset applications restores the original factory values, i.e. the default values shown in the parameters table, except for the parameters that are not present within the preset applications **AP1...AP8** which retain the value set previously. These values, left unaltered, may not be suitable and may therefore need to be changed.

NOTICE

INOPERABLE DEVICE

Verify the parameters after loading a preset application.

Failure to follow these instructions can result in equipment damage.

Flammable refrigerant gases

This equipment is designed to operate in non-hazardous areas and where applications which generate - or could potentially generate - hazardous atmospheres have been isolated. Install this equipment only in areas and with applications known to be constantly free from hazardous atmospheres.

⚠ DANGER

RISK OF EXPLOSION

- Install and use this equipment in non-hazardous locations only.
- Do not install or use this equipment in applications which could generate hazardous atmospheres, such as those using flammable refrigerants.

Failure to follow these instructions will result in death or serious injury.

For information regarding the use of control equipment in applications capable of generating hazardous materials, please contact the regulatory office or the local, regional or national certification authority.

Overview of the range

Contents

This section includes the following topics:

Introduction	13
Box contents	13
Models	14
List of valves	14
Accessories	15
Main features	16
Main components	18

Introduction

General Description

The **RTX 600 IV** family consists of devices used to control remote counters and cold rooms with pulse electronic expansion valve (EEV) management in single or multiple evaporator configuration.

The devices are available in a DIN rail-mounted version.

Every device has 8 preset applications: **AP1...AP8**, that pre-configure the device to work with 8 real usage situations, reducing installation time and only requiring precision changes to parameters.

Main features

The main features are as follows:

- Evaporator overheating regulation via an integrated driver
- 2 ON/OFF regulators for HEAT/COOL
- Single and dual evaporator defrost (heaters, inversion cycle, hot gas)
- Evaporator fans
- Anti-condensation heaters (Frame Heater)
- AUX
- Light
- Door switch
- ON / OFF
- Deep cooling cycle
- Dynamic setpoint
- Day / Night
- Diagnostics
- Preset applications
- Configurable inputs/outputs
- LINK² local network
- Modbus communication protocol via RS485
- Compatibility with Device Manager (DM)
- Compatibility with UNICARD and Multi Function Key (MFK)

In this manual, the photographs and diagrams are provided to illustrate the device (and other Eliwell devices) and are purely illustrative. The corresponding dimensions and proportions may not correspond to actual dimensions in terms of life-size or scale. Furthermore, all the wiring or electrical diagrams should be considered as simplified representations which may not exactly correspond to the reality.

Box contents

The figure below shows the contents of the box:

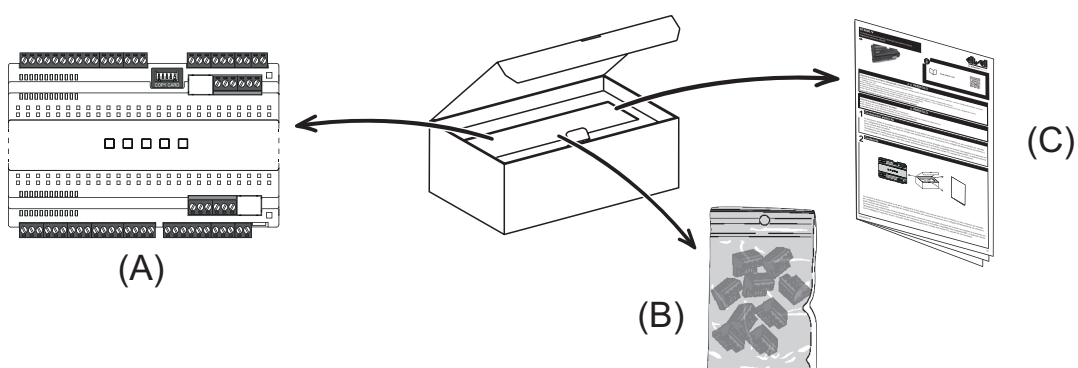



The box contains:

Label	Description
A	Device
B	Disconnectable screw terminals
C	Instruction sheet

Models

The following is a list of models:

Image	Description
	RTX 600 IV DOMINO ZERO
	RTX 600 IV DOMINO ZERO + KDEPlus

List of valves

Below is the list of electronic expansion valves (EEV) compatible with the device and selected via parameter **E00**:

⚠ WARNING
UNINTENDED EQUIPMENT OPERATION
Before using the valve, verify the parameters and the data provided by the valve manufacturer.
Failure to follow these instructions can result in death, serious injury, or equipment damage.

The following valves are **COMPATIBLE** with the **RTX 600 IV** device:

Manufacturer	Valve	Notes
Eliwell by Schneider Electric	PXV	Orifices from 0.5 to 2.7 mm

Accessories

⚡ ⚠ DANGER



RISK OF ELECTRIC SHOCK, FIRE OR ARC FLASH

Only connect compatible accessories to the instrument.

Failure to follow these instructions will result in death or serious injury.

Contact an Eliwell representative for further information regarding the accessories that can be used.

Accessory	Description
	KDX 500/5000
	KDEPlus
	KDWPlus
	Vertical KDT
	Horizontal KDT
	ECPlus
	Multi Function Key (MFK)
	UNICARD USB/TTL EXTENSION CABLE USB-A/A NETWORK POWER SUPPLY USB
	NTC, PTC, Pt1000

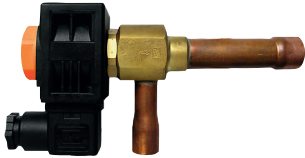
Accessory	Description
	PRESSURE TRANSDUCER (EWPA)
	RATIOMETRIC TRANSDUCER (EWPA)
	Pulse electronic expansion valves (EEV) PXV (with 0.5 to 2.7 mm orifices)

Main features

The devices are available in a DIN rail-mounted version.

The figure below shows a connection example for the device:

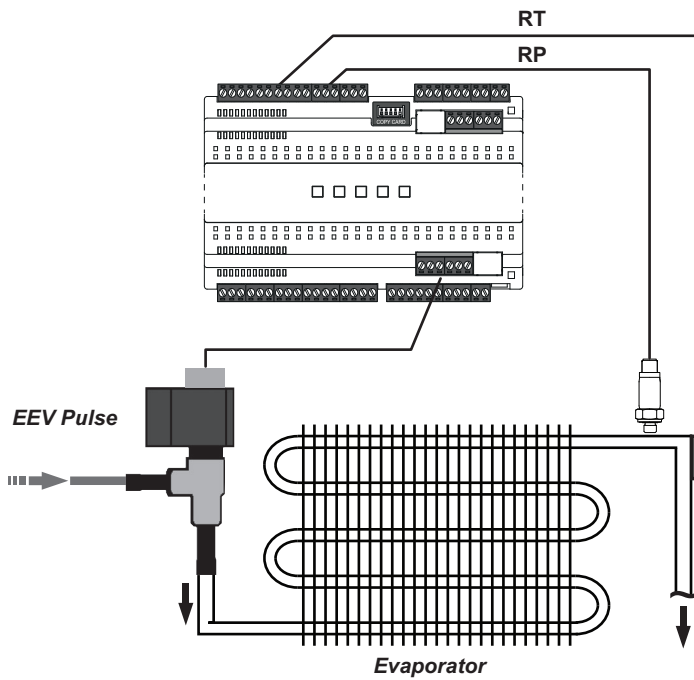

Legend: RT = Refrigerant Temperature; RP = Refrigerant Pressure; EEV Pulse = Pulse Valve; Evaporator = Evaporator.

The **RTX 600 IV** range consists of a base board and a top board.

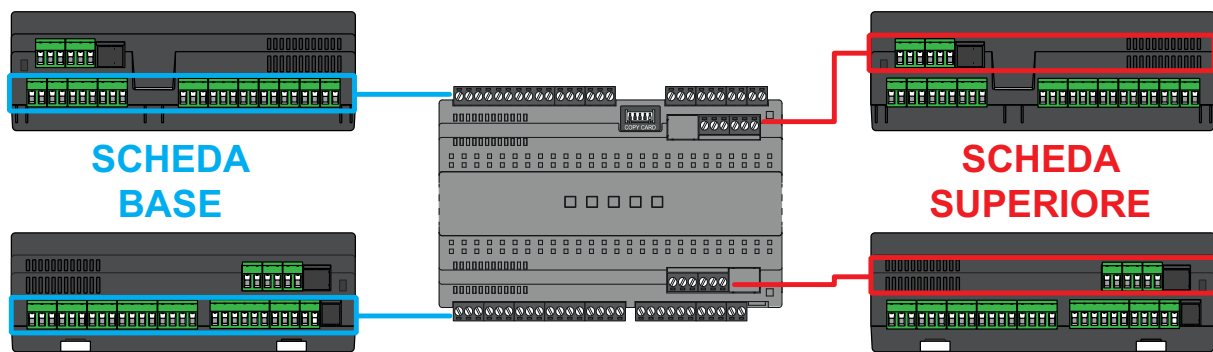

The table below shows the main features of the **RTX 600 IV**

Characteristics	Description
Power supply	SMPS 100...240 Vac ($\pm 10\%$), 50/60 Hz
Input type	<ul style="list-style-type: none"> • 5 configurable NTC/PTC/Pt1000/DI inputs (Pb1...Pb5) • 1 configurable 4...20 mA / DI input (Pb6) • 1 configurable ratiometric / DI input (Pb7) • 1 multifunctional voltage free digital input (DI)
Output type	<ul style="list-style-type: none"> • 5 relay digital outputs • 1 multifunctional OC (Open Collector) output • 1 multifunctional DAC output (0...10 Vdc / 4...20 mA) • 1 pulse EEV driver output on SSR relay with maximum current of 300 mA
Display	NO
Nut	YES
Communication port	<ul style="list-style-type: none"> • 1 TTL for UNICARD / Device Manager connection / Multi Function Key (maximum length 3 m / 9.84 ft.) • 1 opto-isolated RS485 serial port for supervision • 1 serial port for local Link² network connection • 1 serial port for terminal (KDEPlus, KDWPlus, KDT or KDX) or viewer (ECPlus) connection

Main components

The main components of the **RTX 600 IV** are:

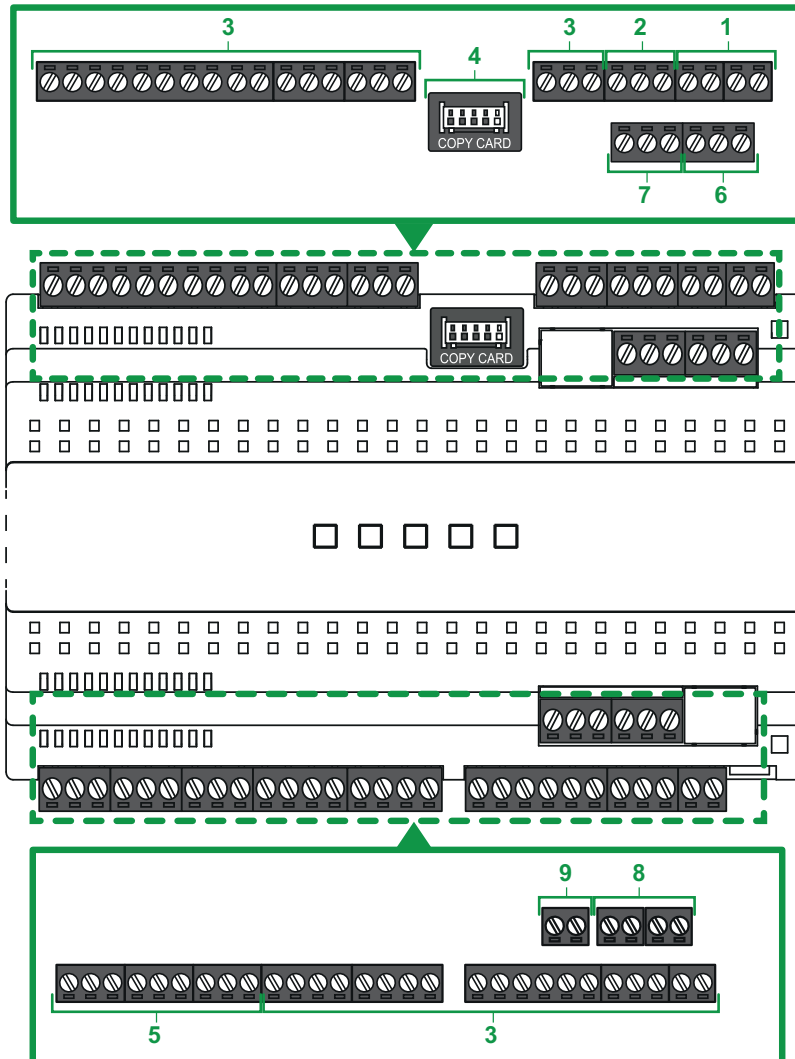

NOTE: in the figure the device has disconnectable screw terminals fitted.

Label	Description	Position	For further information, please refer to:
1	Link2	Base board	Serial connections and Serial ports
2	Terminal	Base board	Serial ports
3	Inputs/Outputs	Base board	Base board wiring diagrams
4	TTL	Base board	Serial ports
5	Power supply	Base board	Power supply
6	RS485-1 port	Top board	Serial connections and Serial ports
7	RS485-2 port	Top board	Serial connections and Serial ports
8	Pulse EEV power supply	Top board	Pulse EEV power supply
9	Pulse EEV output	Top board	Top board wiring diagram

Preliminary configurations

Contents

This section includes the following topics:

Introduction	20
Available applications	21
Application AP1	22
Application AP2	23
Application AP3	24
Application AP4	25
Application AP5	26
Application AP6	27
Application AP7	28
Application AP8	29

Introduction

Overview

The **RTX 600 IV** family consists of devices used to control remote counters and cold rooms with pulse electronic expansion valve (EEV) management in single or multiple evaporator configuration.

Every device has 8 preset applications: **AP1...AP8**, that pre-configure the device to work with 8 real usage situations, reducing installation time and only requiring precision changes to parameters.

Applications

Changing the controller operating parameters does not affect the preset application values. The first time the instrument is switched on, the operating parameters are the same (for value and visibility) as those for application **AP1**.

Applications **AP1...AP8** cannot be edited from the instrument but only via Device Manager, a software program available to download from the www.eliwell.com website.









Switching on for the first time

Once the electrical connections have been completed, simply power up the device for it to start working. At the first startup:

1. Select and load the preset application - **AP1...AP8** - that best reflects the usage requirements.
2. Verify and, if necessary, adjust the value of the main device parameters to adapt the selected application to your system.
3. Make sure there are no active alarms (see alarms section).

Loading Preset Applications

The procedure for loading one of the preset applications is:

1. Switch on the terminal connected to the device; press and hold  until label "AP1" appears.
Note: On the **KDT** terminal, within 30 seconds of switching the device on, press and hold any button for a least 1 second to unlock the terminal and then press and hold  and  simultaneously until label "AP1" appears.
Note: On the **KDX** terminal, within 30 seconds of switching the device on, press  and  simultaneously until label "AP1" appears.
2. Scroll through applications **AP1...AP8** using  and .
3. Confirm the selected preset application using .
Note: The process can be canceled by pressing  or letting a timeout occur (15 seconds)
4. If the procedure was completed successfully, the display will show "**yES**"; otherwise it will show "**Err**".
5. The device will restart and revert to showing the main display

The procedure for loading one of the preset applications restores the respective default values, with the exception of the parameters NON specific to the application that retain the value set previously. These values, left unaltered, may not be suitable and may therefore need to be changed.

NOTICE

INOPERABLE DEVICE

Verify the parameters after loading a preset application.

Failure to follow these instructions can result in equipment damage.

Available applications

Description

Below is a short description of the preset applications:

- **AP1:** NT "REFRIGERATED CABINETS" (0°C / 32°F) for the storage of Dairy products, Fruit/Vegetables and Frozen food.
- **AP2:** AT "REFRIGERATED CABINETS" (3°C / 37.4°F) for the storage of Dairy products, Fruit/Vegetables and Frozen food.
- **AP3:** LT "REFRIGERATED CABINETS" (-18°C / 0.4°F) for the storage of Frozen food.
- **AP4:** NT "COLD ROOMS" (0°C / 32°F) for the storage of Dairy products, Fruit/Vegetables and Frozen food.
- **AP5:** AT "COLD ROOMS" (3°C / 37.4°F) for the storage of Dairy products, Fruit/Vegetables and Frozen food.
- **AP6:** LT "COLD ROOMS" (-18°C / 0.4°F) for the storage of Frozen food.
- **AP7:** LT "HORIZONTAL ISLAND" (-18°C / 0.4°F) for the storage of Frozen food.
- **AP8:** LT "COMBINED UPRIGHT REFRIGERATED CABINETS" (-18°C / 0.4°F) for the storage of Frozen food.

Summary

FUNCTIONS/ APPLICATIONS		AP1	AP2	AP3	AP4	AP5	AP6	AP7	AP8
INPUTS									
Pb1	NTC	REG1/(●)	REG1/(●)	REG1/(●)	REG1/(●)	REG1/(●)	REG1/(●)	REG1/(●)	REG1/(●)
Pb2	NTC								REG2/(●)
Pb3	NTC	-	-	-	-	-	-	-	
Pb4	NTC	-	-	-	-	-	-	-	-
Pb5	NTC	EEV	EEV	EEV	EEV	EEV	EEV	EEV	EEV
Pb6	4...20 mA	EEV	EEV	EEV	EEV	EEV	EEV	EEV	EEV
Pb7	Ratiometric	-	-	-	-	-	-	-	-
DI	Digital Input	-	-	-				-	-
OUTPUTS									
Out 1	Relay								
Out 2	Relay								
Out 3	Relay								
Out 4	Relay								
Out 5	Relay	AUX	AUX	AUX	-	-	-	-	-
EEV	Output	EEV	EEV	EEV	EEV	EEV	EEV	EEV	EEV
A OUT	Output	-	-	-	-	-	-	-	-
OC	Output	-	-	-	-	-	-	-	-
INPUTS / OUTPUTS ONLY PRESENT ON KDX TERMINAL									
Pb8	4...20 mA	-	-	-	-	-	-	-	-
DI1	Digital Input	-	-	-	-	-	-	-	-
DI2	Digital Input	-	-	-	-	-	-	-	-

Legend:

REG1 = Regulator 1.	= Alarm regulator.
REG2 = Regulator 2.	= Defrost regulator.
EEV = EEV input or output.	= Compressor regulator.
AUX = Auxiliary output regulator.	= Fan regulator.
= Door switch regulator.	= Light regulator.

Regulation

Regulator 1 (**REG1**) will be activated when the temperature exceeds the value $T > SP1 + dF1$, and will be deactivated when $T < SP1$. For these applications, the regulation differential will work in relative mode.

Application AP1

Overview

The application is configured for NT “REFRIGERATED CABINETS” (0°C / 32°F) for the storage of Dairy products, Fruit/Vegetables and Frozen food. The set configuration is intended for:

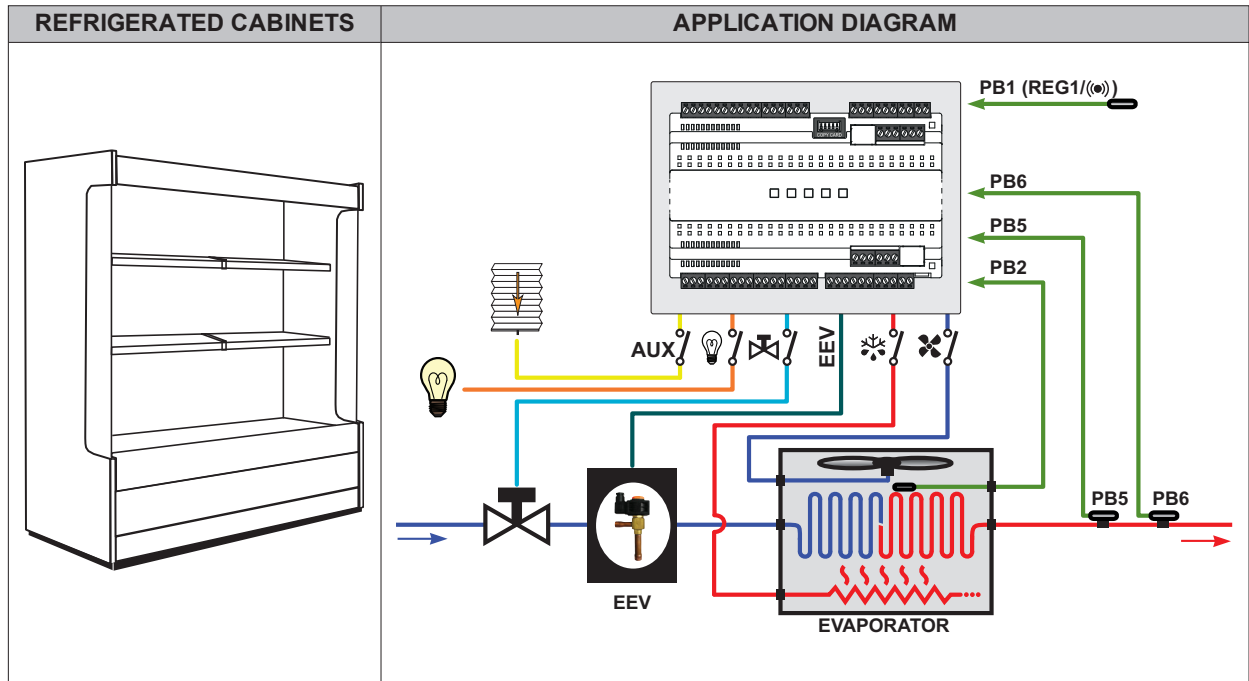

Legend: REG1 = Regulator 1; EEV = Electronic expansion valve; Evaporator = Evaporator.

Application details

Input configuration:

- Pb1 input = Regulation 1 / Alarm
- Pb2 input = Defrost / Evaporator fans
- Pb3 input = Not set
- Pb4 input = Not set
- Pb5 input = EEV temperature sensor
- Pb6 input = EEV pressure transducer
- Pb7 input = Not set
- DI input = Not set

Output configuration:

- OUT1 (relay) = Compressor
- OUT2 (relay) = Evaporator fans
- OUT3 (relay) = Defrost
- OUT4 (relay) = Light
- OUT5 (relay) = AUX
- EEV = EEV valve
- A OUT = Not set
- OC = Not set

Application AP2

Overview

The application is configured for AT “REFRIGERATED CABINETS” (3°C / 37.4°F) for the storage of Dairy products, Fruit/Vegetables and Frozen food. The set configuration is intended for:

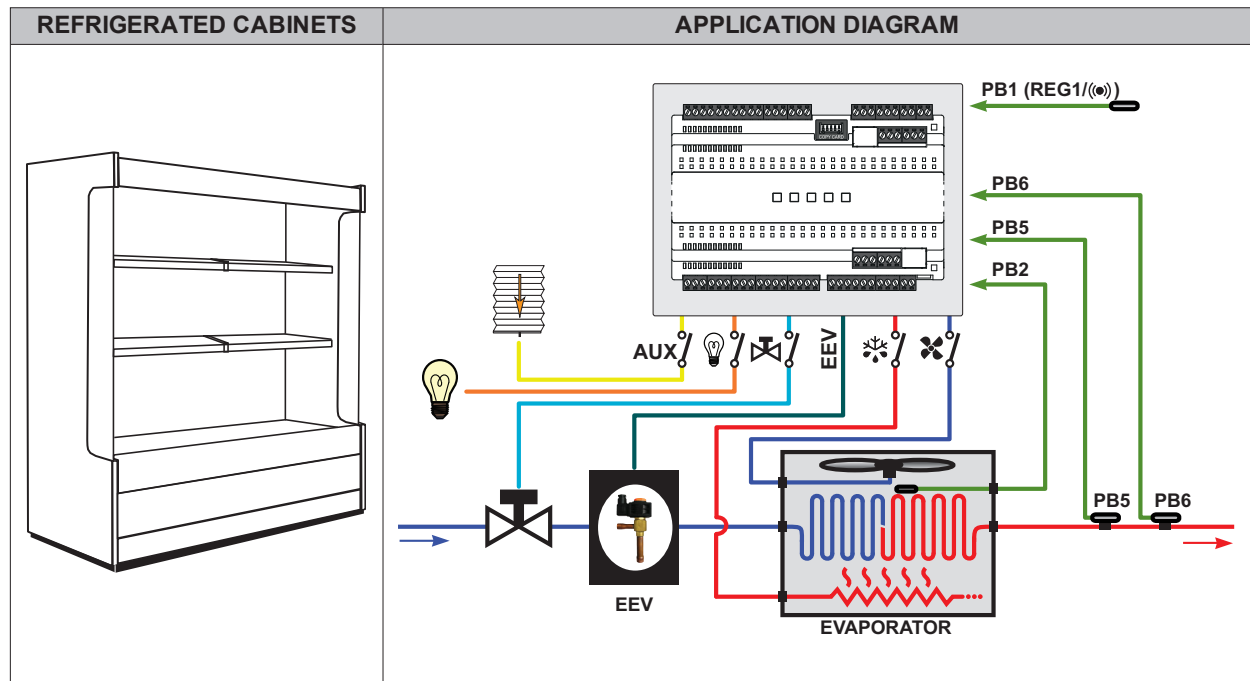

Legend: REG1 = Regulator 1; EEV = Electronic expansion valve; Evaporator = Evaporator.

Application details

Input configuration:

- Pb1 input = Regulation 1 / Alarm
- Pb2 input = Defrost / Evaporator fans
- Pb3 input = Not set
- Pb4 input = Not set
- Pb5 input = EEV temperature sensor
- Pb6 input = EEV pressure transducer
- Pb7 input = Not set
- DI input = Not set

Output configuration:

- OUT1 (relay) = Compressor
- OUT2 (relay) = Evaporator fans
- OUT3 (relay) = Defrost
- OUT4 (relay) = Light
- OUT5 (relay) = AUX
- EEV = EEV valve
- A OUT = Not set
- OC = Not set

Application AP3

Overview

The application is configured for LT "REFRIGERATED CABINETS" (-18°C / 0.4°F) for the storage of Frozen food. The set configuration is intended for:

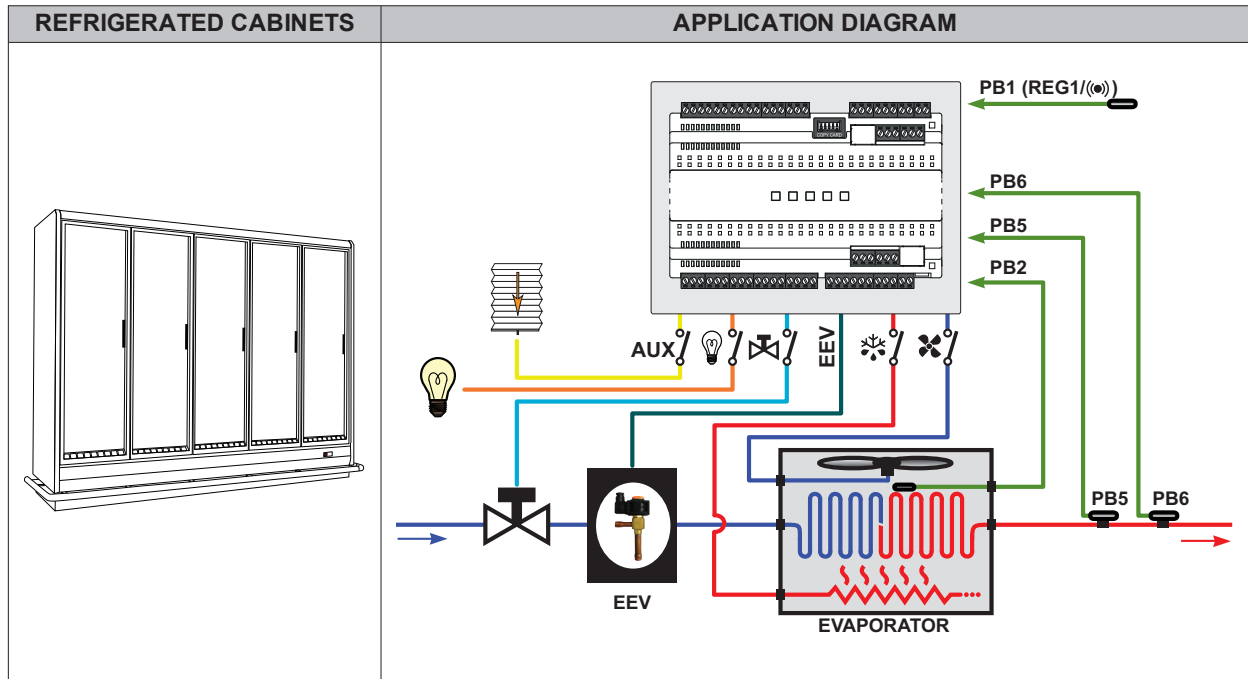

Legend: REG1 = Regulator 1; EEV = Electronic expansion valve; Evaporator = Evaporator.

Application details

Input configuration:

- Pb1 input = Regulation 1 / Alarm
- Pb2 input = Defrost / Evaporator fans
- Pb3 input = Not set
- Pb4 input = Not set
- Pb5 input = EEV temperature sensor
- Pb6 input = EEV pressure transducer
- Pb7 input = Not set
- DI input = Not set

Output configuration:

- OUT1 (relay) = Compressor
- OUT2 (relay) = Evaporator fans
- OUT3 (relay) = Defrost
- OUT4 (relay) = Light
- OUT5 (relay) = AUX
- EEV = EEV valve
- A OUT = Not set
- OC = Not set

Application AP4

Overview

The application is configured for NT “COLD ROOMS” (0°C / 32°F) for the storage of Dairy products, Fruit/Vegetables and Frozen food. The set configuration is intended for:

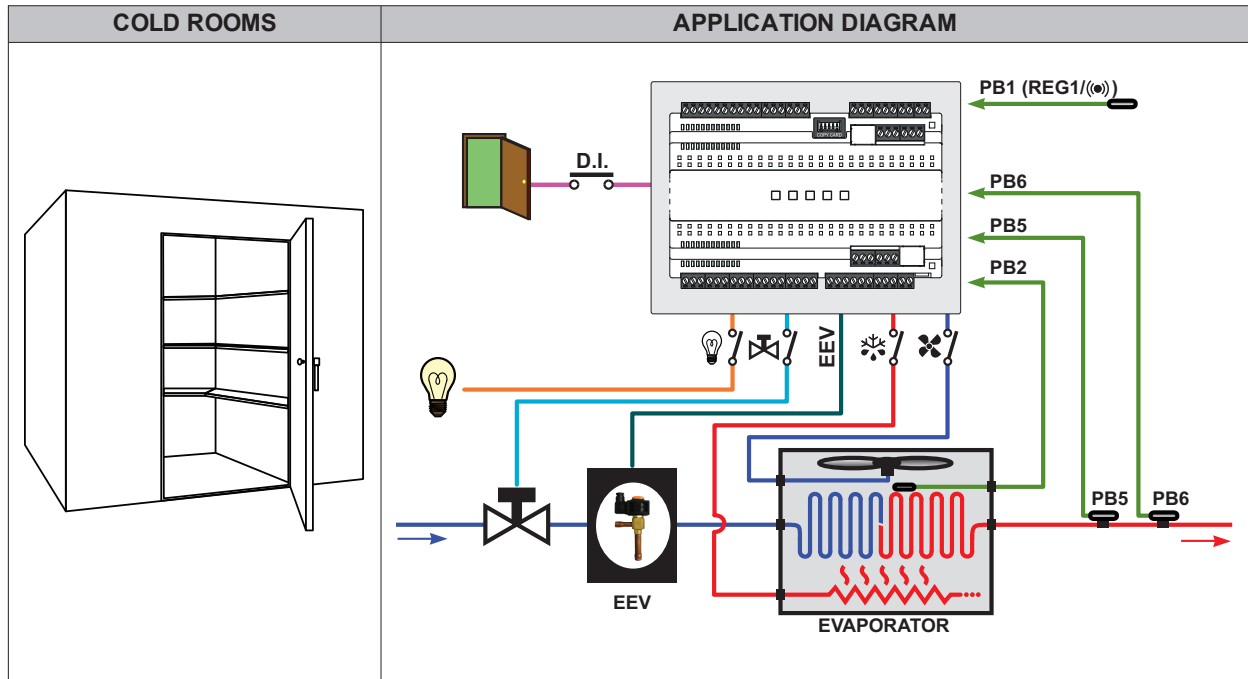

Legend: REG1 = Regulator 1; EEV = Electronic expansion valve; Evaporator = Evaporator.

Application details

Input configuration:

- Pb1 input = Regulation 1 / Alarm
- Pb2 input = Defrost / Evaporator fans
- Pb3 input = Not set
- Pb4 input = Not set
- Pb5 input = EEV temperature sensor
- Pb6 input = EEV pressure transducer
- Pb7 input = Not set
- Pb8 input = Not set (present on terminal KDX)
- DI input = Door switch

Output configuration:

- OUT1 (relay) = Compressor
- OUT2 (relay) = Evaporator fans
- OUT3 (relay) = Defrost
- OUT4 (relay) = Light
- OUT5 (relay) = Not set
- EEV = EEV valve
- A OUT = Not set
- OC = Not set

Application AP5

Overview

The application is configured for AT “**COLD ROOMS**” (3°C / 37.4°F) for the storage of Dairy products, Fruit/Vegetables and Frozen food. The set configuration is intended for:

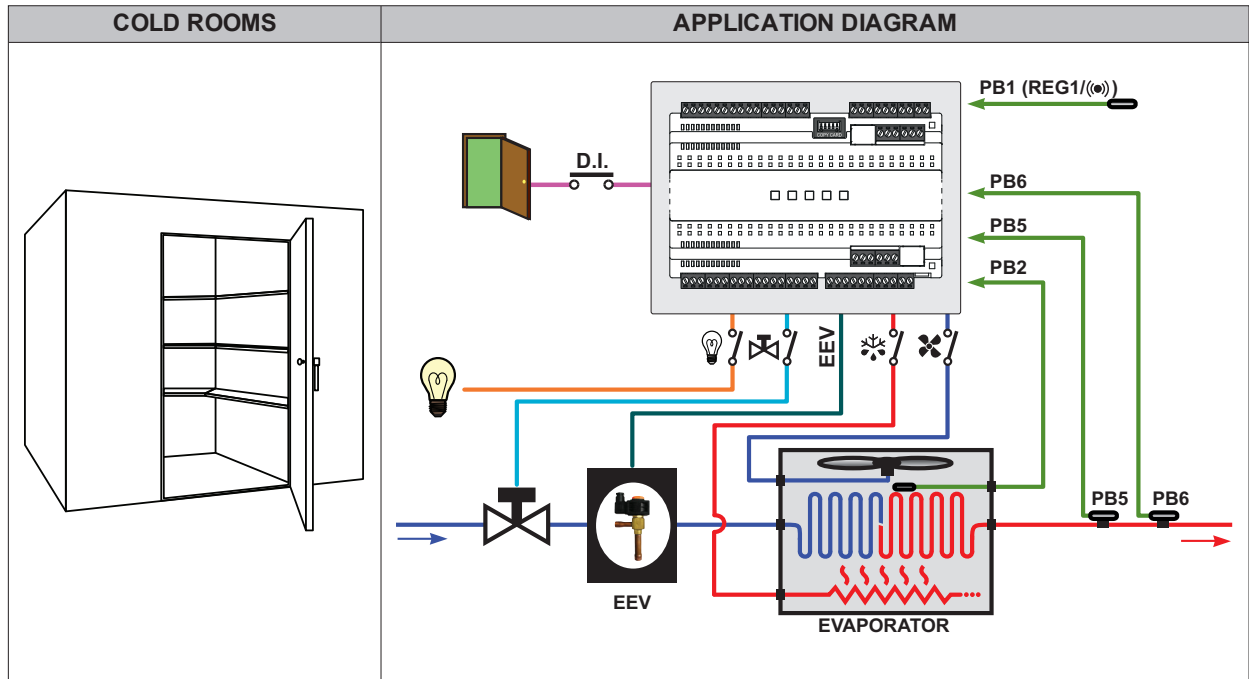

Legend: REG1 = Regulator 1; EEV = Electronic expansion valve; Evaporator = Evaporator.

Application details

Input configuration:

- Pb1 input = Regulation 1 / Alarm
- Pb2 input = Defrost / Evaporator fans
- Pb3 input = Not set
- Pb4 input = Not set
- Pb5 input = EEV temperature sensor
- Pb6 input = EEV pressure transducer
- Pb7 input = Not set
- Pb8 input = Not set (present on terminal KDX)
- DI input = Door switch

Output configuration:

- OUT1 (relay) = Compressor
- OUT2 (relay) = Evaporator fans
- OUT3 (relay) = Defrost
- OUT4 (relay) = Light
- OUT5 (relay) = Not set
- EEV = EEV valve
- A OUT = Not set
- OC = Not set

Application AP6

Overview

The application is configured for LT "COLD ROOMS" (-18°C / 0.4°F) for the storage of Frozen food. The set configuration is intended for:

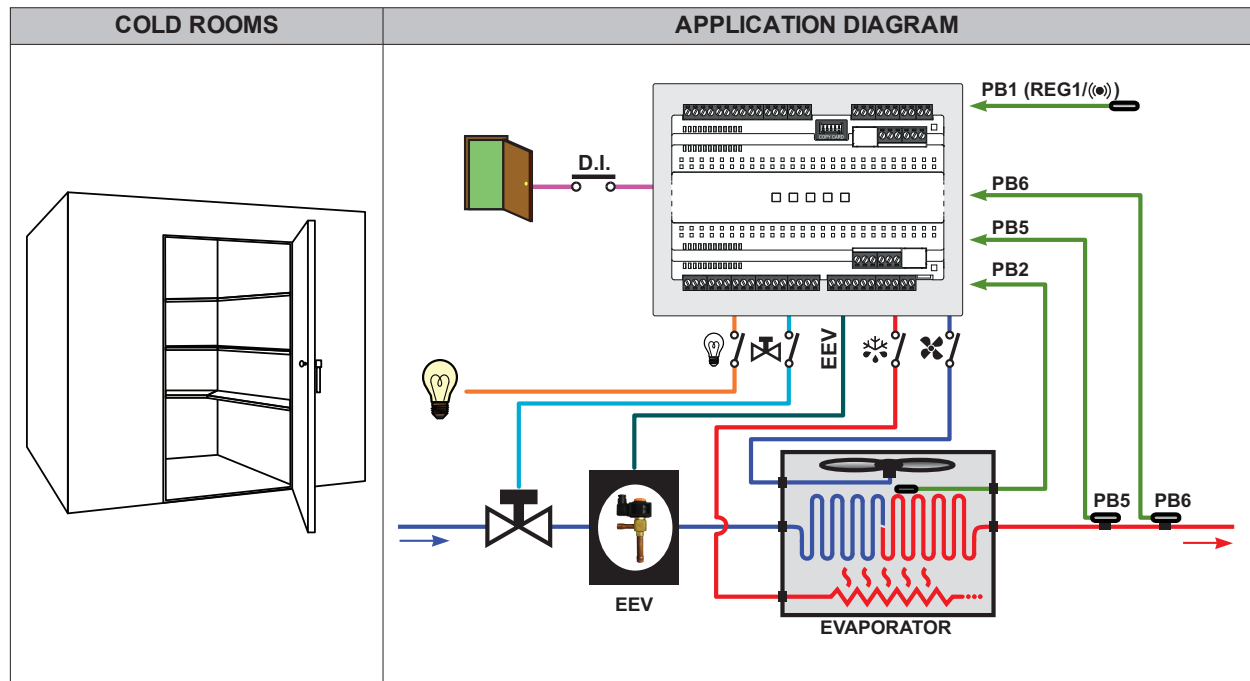

Legend: REG1 = Regulator 1; EEV = Electronic expansion valve; Evaporator = Evaporator.

Application details

Input configuration:

- Pb1 input = Regulation 1 / Alarm
- Pb2 input = Defrost / Evaporator fans
- Pb3 input = Not set
- Pb4 input = Not set
- Pb5 input = EEV temperature sensor
- Pb6 input = EEV pressure transducer
- Pb7 input = Not set
- Pb8 input = Not set (present on terminal KDX)
- DI input = Door switch

Output configuration:

- OUT1 (relay) = Compressor
- OUT2 (relay) = Evaporator fans
- OUT3 (relay) = Defrost
- OUT4 (relay) = Light
- OUT5 (relay) = Not set
- EEV = EEV valve
- A OUT = Not set
- OC = Not set

Application AP7

Overview

The application is configured for LT "HORIZONTAL ISLAND" (-18°C / 0.4°F) for the storage of Frozen food. The set configuration is intended for:

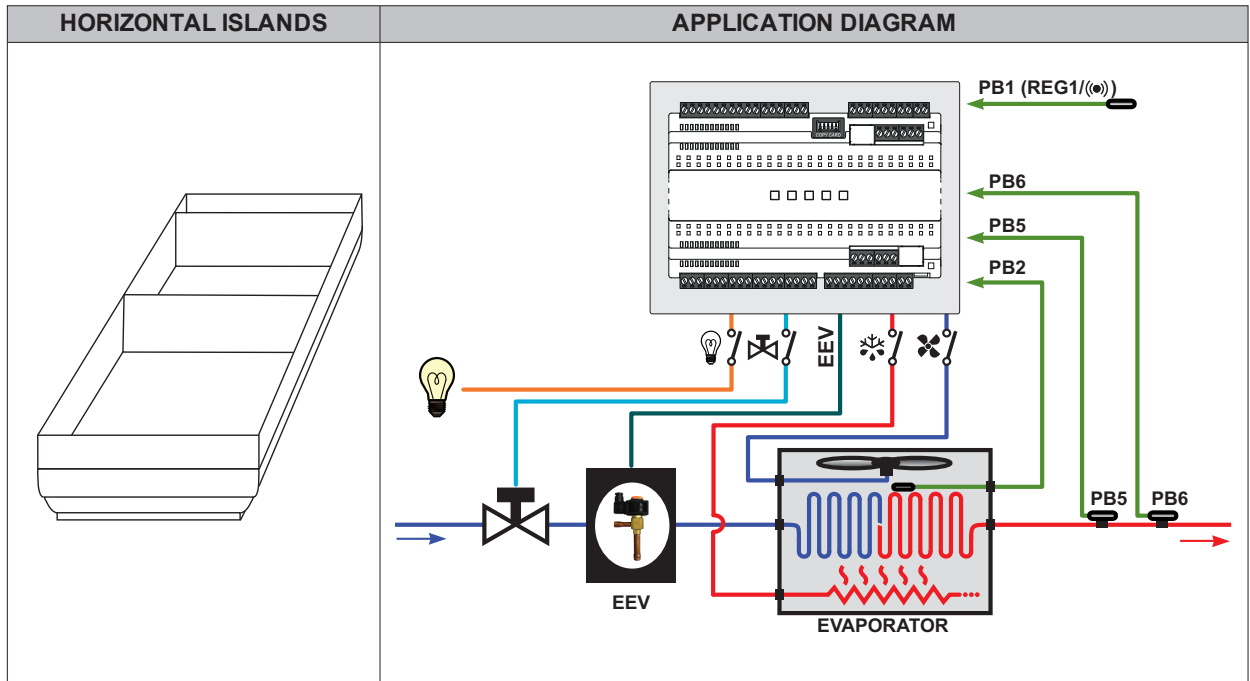

Legend: REG1 = Regulator 1; EEV = Electronic expansion valve; Evaporator = Evaporator.

Application details

Input configuration:

- Pb1 input = Regulation 1 / Alarm
- Pb2 input = Defrost / Evaporator fans
- Pb3 input = Not set
- Pb4 input = Not set
- Pb5 input = EEV temperature sensor
- Pb6 input = EEV pressure transducer
- Pb7 input = Not set
- DI input = Not set

Output configuration:

- OUT1 (relay) = Compressor
- OUT2 (relay) = Evaporator fans
- OUT3 (relay) = Defrost
- OUT4 (relay) = Light
- OUT5 (relay) = Not set
- EEV = EEV valve
- A OUT = Not set
- OC = Not set

Application AP8

Overview

The application is configured for LT “**COMBINED UPRIGHT REFRIGERATED CABINETS**” (-18°C / 0.4°F) for the storage of Frozen food. The set configuration is intended for:

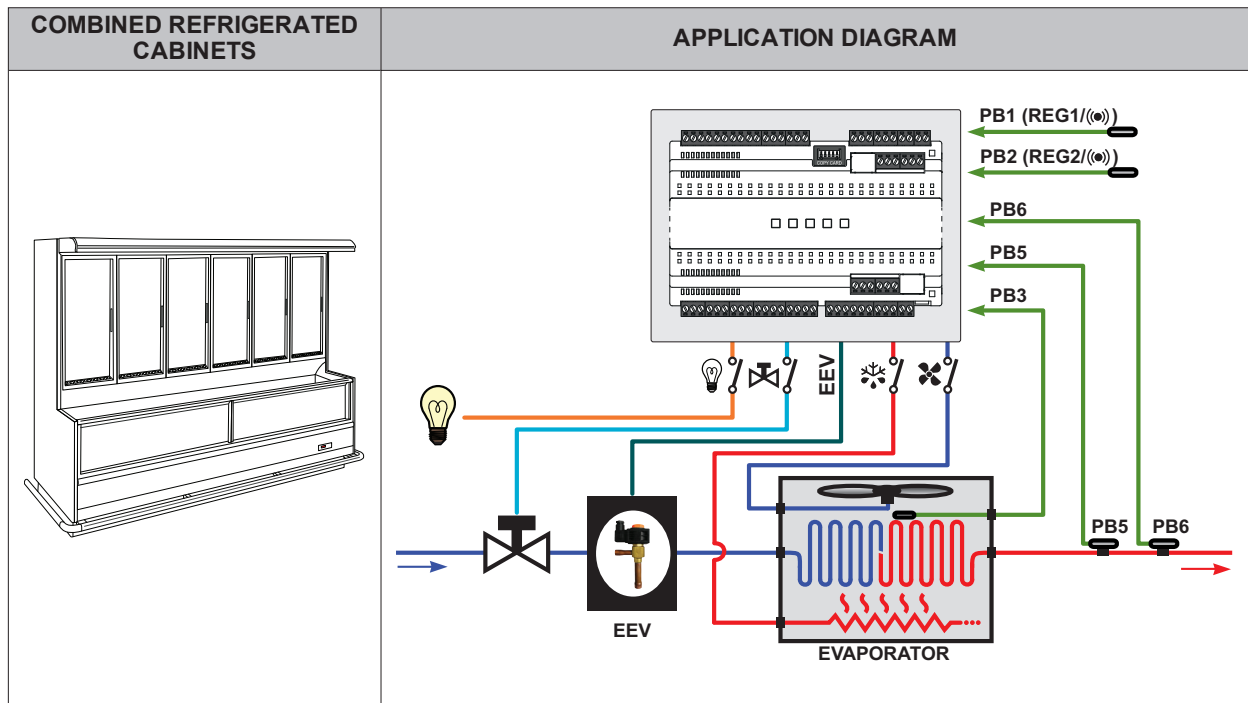

Legend: REG1 = Regulator 1; EEV = Electronic expansion valve; Evaporator = Evaporator.

Application details

Input configuration:

- Pb1 input = Regulation 1 / Alarm
- Pb2 input = Regulation 2 / Alarm
- Pb3 input = Defrost / Evaporator fans
- Pb4 input = Not set
- Pb5 input = EEV temperature sensor
- Pb6 input = EEV pressure transducer
- Pb7 input = Not set
- DI input = Not set

Output configuration:

- OUT1 (relay) = Compressor
- OUT2 (relay) = Evaporator fans
- OUT3 (relay) = Defrost
- OUT4 (relay) = Light
- OUT5 (relay) = Not set
- EEV = EEV valve
- A OUT = Not set
- OC = Not set

Mechanical installation

Contents

This section includes the following topics:

Before starting	31
Power supply disconnection	31
Considerations concerning programming	31
Operating environment	32
Comments concerning installation	32
Installation	33

Before starting

Read this manual carefully before installing the device and its accessories.

In particular, ensure conformity with all safety indications, electrical requirements and current legislation for the machine or the process used with this equipment.

The use and application of information contained herein requires experience in the design and programming of automated control systems. Only the machine user, integrator or manufacturer will be aware of all the conditions and factors affecting installation, configuration, operation and maintenance of the machine or process and can therefore identify the associated equipment and corresponding safety interlocks and systems that can be used appropriately and efficiently. When selecting automation and control equipment, other equipment and connected software for a particular application, all local, regional and national standards and/or legislation must be taken into account.

WARNING

REGULATORY INCOMPATIBILITY

Make sure that all equipment used and systems designed comply with all applicable local, regional and national laws.

Failure to follow these instructions can result in death, serious injury, or equipment damage.

Power supply disconnection

Assemble and install all optional extras and modules before installing the control system on an assembly rail, panel door or other assembly surface.

Before dismantling the equipment, remove the control systems from the assembly rail, plate or panel.

DANGER

RISK OF ELECTRIC SHOCK, EXPLOSION, FIRE OR ARC FLASH

- Disconnect all power from all equipment including connected devices prior to removing any covers or doors, or installing or removing any accessories, hardware, cables or wires except under the specific conditions specified in this user manual.
- Always use a properly rated voltage sensing device to confirm the power is off where and when indicated.
- Before restoring the power supply, replace and secure all covers, hardware components and cables.
- For all the devices requiring it, make sure there is an effective ground connection.
- Use only the specified voltage when operating this device and any associated products.
- Do not connect the device directly to the line voltage, unless expressly indicated.

Failure to follow these instructions will result in death or serious injury.

Considerations concerning programming

The devices described in this manual are designed and tested using Eliwell programming, configuration and maintenance software.

Operating environment

This equipment is designed to operate in non-hazardous areas and where applications which generate - or could potentially generate - hazardous atmospheres have been isolated. Install this equipment only in areas and with applications known to be constantly free from hazardous atmospheres.

⚠ DANGER
RISK OF EXPLOSION
<ul style="list-style-type: none"> • Install and use this equipment in non-hazardous locations only. • Do not install or use this equipment in applications which could generate hazardous atmospheres, such as those using flammable refrigerants.
Failure to follow these instructions will result in death or serious injury.

For information regarding the use of control equipment in applications capable of generating hazardous materials, please contact the regulatory office or the local, regional or national certification authority.

⚠ WARNING
UNINTENDED EQUIPMENT OPERATION
Install and use this equipment in compliance with the conditions described in the "Environmental and electrical characteristics" section of this document.
Failure to follow these instructions can result in death, serious injury, or equipment damage.

Comments concerning installation

Device

⚠ WARNING
UNINTENDED EQUIPMENT OPERATION
<ul style="list-style-type: none"> • Use appropriate safety interlocks where personnel and/or equipment hazards exist. • Install and operate this equipment in an enclosure appropriately rated for its intended environment and secured by a keyed or tooled locking mechanism. • Power line and output circuits must be wired and fused in compliance with local and national regulatory requirements for the rated current and voltage of the particular equipment. • Do not use this equipment for safety-critical functions. • Do not disassemble, repair, or modify this equipment.
Failure to follow these instructions can result in death, serious injury, or equipment damage.

For mechanical dimensions, refer to the **Mechanical Dimensions** section.

RTX 600 /V Devices are designed for DIN rail mounting on the "top hat" section.

Terminals and echo viewer

The end application must prevent access to hazardous live or moving parts through the hole used to mount the terminal (**KDEPlus**, **KDWPlus**, **KDT** or **KDX**) or the echo viewer (**ECPlus**) as the terminal and viewer do not offer protection from this scenario.

⚡ ⚠ DANGER
RISK OF ELECTRIC SHOCK OR ACCESS TO MOVING PARTS
Make sure the terminal or viewer is installed correctly.
Failure to follow these instructions will result in death or serious injury.

Mechanical dimensions

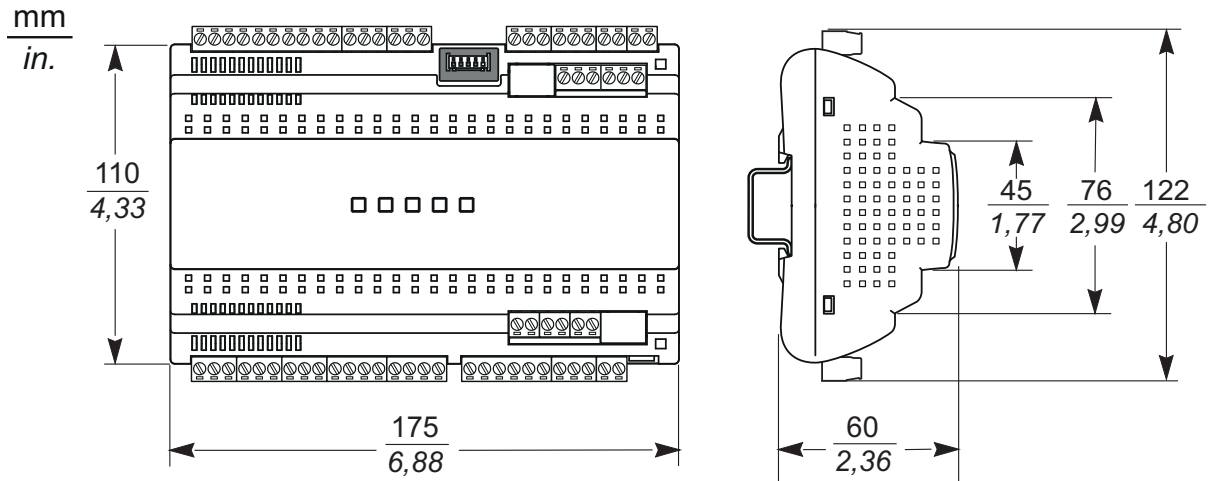

Installation

How to install the device

For installation, proceed as follows:

1. Shift the lower locking clip on the bottom part outwards, as shown in the diagram below (use a screwdriver or similar tool as a lever). Make sure the upper locking clip located on the top part remains fully in place
2. Fit the device onto the DIN rail
3. Press the clips inwards until you hear them click into place

Note: Once the device has been assembled on the DIN rail, make sure the spring docking devices are facing downwards.

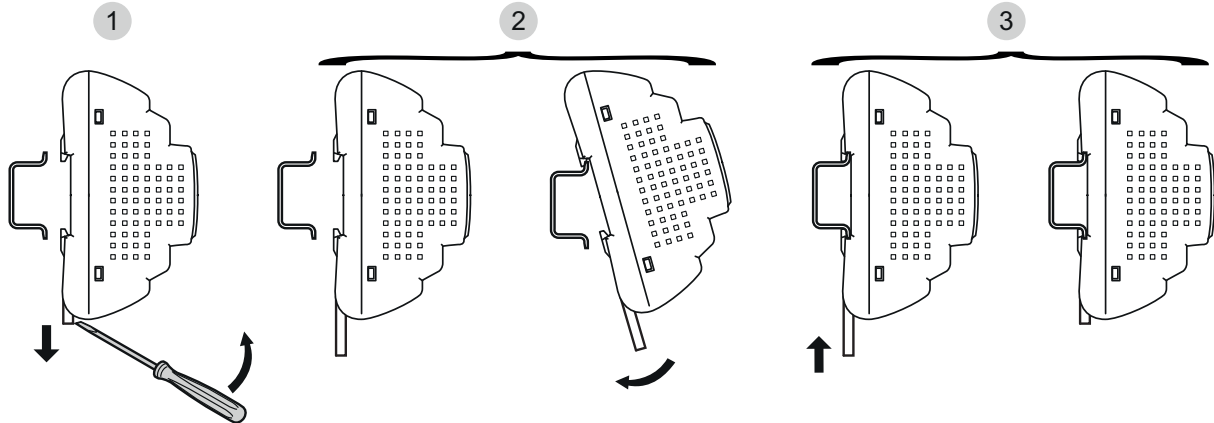

NSYSDR200
IEC/EN60715

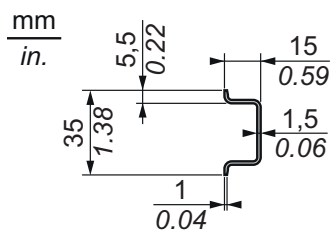

NSYSDR200BD

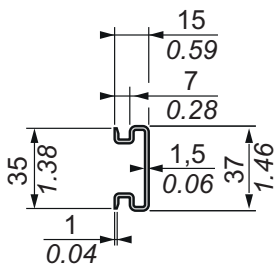

NSYSDR200T

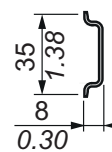

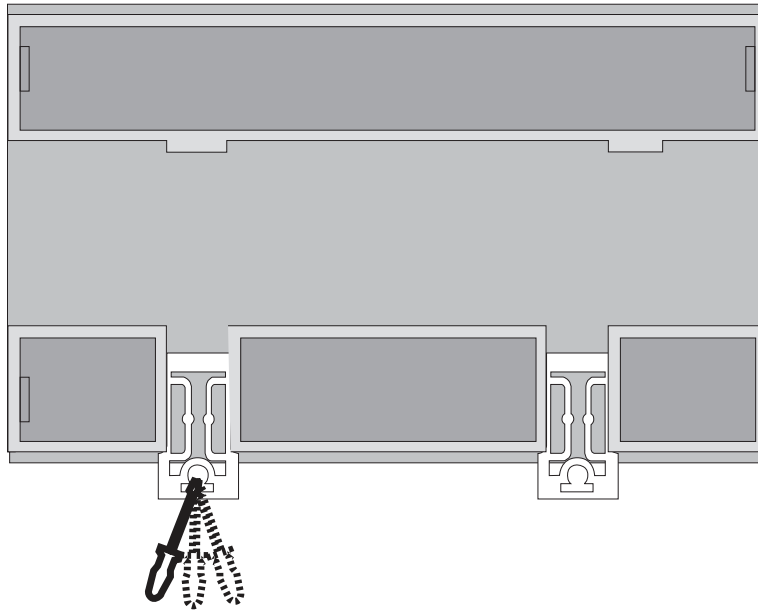

The **RTX 600 IV** device was designed as an IP20 product for installation in approved cabinets and/or in areas that prevent unauthorized access.

When installing the device, observe the following distances:

- **RTX 600 IV** and all sides of the cabinet (including the panel door)
- The **RTX 600 IV** terminal blocks and the cable routing ducts. These distances reduce electromagnetic interference between the device and the cable routing ducts
- **RTX 600 IV** and other heat-generating devices installed in the same cabinet

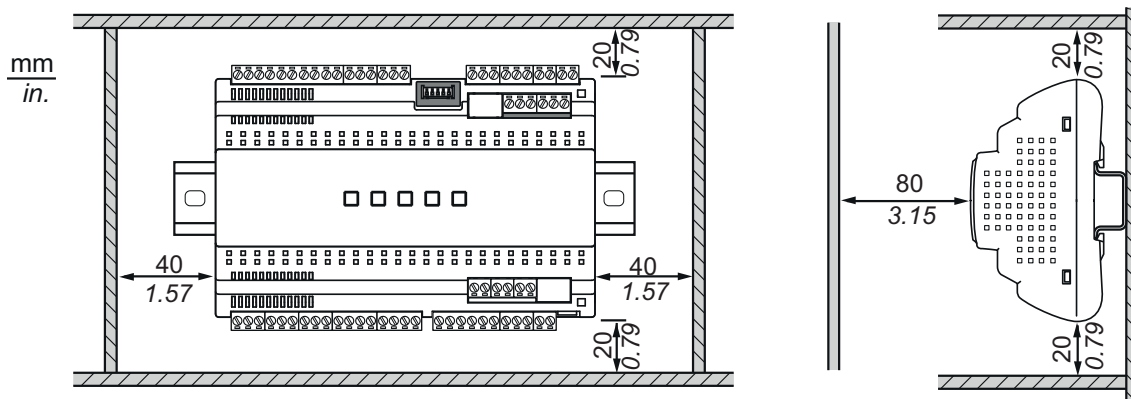

⚠ WARNING

UNINTENDED EQUIPMENT OPERATION

- Place the devices dissipating the most heat at the top of the cabinet and ensure suitable ventilation.
- Do not place the device near or above other devices that could cause overheating.
- Install the device in a point that guarantees the minimum distances from all structures and adjacent equipment as indicated in this document.
- Install all equipment in conformity with the technical specifications given in the corresponding documentation.

Failure to follow these instructions can result in death, serious injury, or equipment damage.

Electrical connections



Contents

This section includes the following topics:

Best wiring practices	36
Wiring guidelines	37
Serial connections	42
Connectors	43
Wiring diagrams	45

Best wiring practices

The following information describes wiring guidelines and the practices to observe when using the device.

  DANGER
RISK OF ELECTRIC SHOCK, EXPLOSION, FIRE OR ARC FLASH
<ul style="list-style-type: none">• Disconnect all power from all equipment including connected devices prior to removing any covers or doors, or installing or removing any accessories, hardware, cables or wires except under the specific conditions specified in this user manual.• Always use a properly rated voltage sensing device to confirm the power is off where and when indicated.• Before restoring the power supply, replace and secure all covers, hardware components and cables.• For all the devices requiring it, make sure there is an effective ground connection.• Use only the specified voltage when operating this device and any associated products.• Do not connect the device directly to the line voltage, unless expressly indicated.
Failure to follow these instructions will result in death or serious injury.

The end application must prevent access to hazardous live or moving parts through the hole used to mount the terminal (**KDEPlus**, **KDWPlus**, **KDT** or **KDX**) or the viewer (**ECPlus**) as the terminal and viewer do not offer protection from this scenario.

  DANGER
RISK OF ELECTRIC SHOCK OR ACCESS TO MOVING PARTS
Make sure the terminal or viewer is installed correctly.
Failure to follow these instructions will result in death or serious injury.

 WARNING
LOSS OF CONTROL
<ul style="list-style-type: none">• The system designer must consider the potential failure modes of the control circuit and, for some critical control functions, provide a means for reaching a safe condition during and after a circuit failure. Examples of critical control functions are the emergency stop and end of travel stop, power supply cut-off and restart.• Separate or redundant control circuits must be provided for critical control functions.• The system control circuits can include communication connections. Keep in mind the implications of transmission delays or sudden connection failures.• Comply with all standards regarding accident prevention and local applicable safety directives.• Every implementation of this equipment must be tested individually and completely in order to verify its proper operation before it is commissioned.
Failure to follow these instructions can result in death, serious injury, or equipment damage.

Wiring guidelines

When wiring the device, the following standards must be observed:

- The I/O and communication wiring must be kept separate from the electrical wiring. These 2 types of wiring must be kept in separate raceways.
- Make sure that the operating conditions and surrounding environment comply with the specification values.
- Use wires of the correct diameter and suited to the voltage and current requirements.
- Use copper conductors (obligatory).
- Use twisted-pair shielded wires for analog I/Os.
- Use twisted-pair shielded wires for networks and field buses.

Use correctly earthed shielded wires for all analog inputs or outputs and communication connections. If shielded wires cannot be used for these connections, the electromagnetic interference may deteriorate the signal. Deteriorated signals can result in the devices, modules or attached equipment operating incorrectly.

WARNING

UNINTENDED EQUIPMENT OPERATION

- Use shielded wires for all analog I/O and communication signals.
- Ground the wire shields for all analog I/O and communication signals in a single point (1).
- The signal cables (probes, digital inputs, communication, and relative power supplies) must be laid separately from the device power cables.
- Reduce the length of the wires and cables as much as possible and avoid winding them around electrically connected parts.

Failure to follow these instructions can result in death, serious injury, or equipment damage.

(1) Grounding in several points is permitted if the connections are made to an equipotential ground surface that is sized to avoid damage to the cable shields in the event of a short circuit in the power supply.

Note: Lay the main wiring (power wires) separately from the secondary wiring (very low voltage wire coming from intermediate power sources). Where this is not possible, double insulation is required in the form of cable recesses or raceways.

Rules for disconnectable terminal blocks

DANGER









LOOSE WIRING CAN RESULT IN ELECTRIC SHOCK AND/OR FIRE

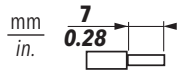

- Tighten the connections in compliance with the technical specifications for torque values and make sure the wiring is correct.
- Do not insert more than one cable per terminal board connector unless you are using the ends of the cables (terminals).

Failure to follow these instructions will result in death or serious injury.

Use copper wires (obligatory).

The table below shows the type and size of permitted cables for disconnectable screw terminals and the corresponding torque values:

								
$\frac{\text{mm}}{\text{in.}}$ 7 0.28								
mm²	0.2...2.5	0.2...2.5	0.25...2.5	0.25...2.5	2 x 0.2...1	2 x 0.2...1.5	2 x 0.25...1	2 x 0.5...1.5
AWG	24...14	24...14	22...14	22...14	2 x 24...18	2 x 24...16	2 x 22...18	2 x 20...16

		N•m	0.5...0.6
Ø 3.5 mm (0.14 in.)		lb-in	4.42...5.31

WARNING

RISK OF OVERHEATING AND/OR FIRE

- Power lines and output connections must be suitably wired and protected by means of fuses when required by national and local regulations.
- Use only the recommended wire cross-sections for the current capacity of the I/O channels and the electrical power.
- Connect the relay outputs, including the shared hub, using wires with a cross-section of at least 2.0 mm² (AWG 14), with a nominal temperature value of at least 80°C (176°F).

Failure to follow these instructions can result in death, serious injury, or equipment damage.

Protecting the outputs from damage from inductive loads

If the device has relay outputs, these types of outputs can cope with up to 240 Vac.

Damage from inductive loads to these types of outputs can cause the contacts to weld and lead to the loss of control. Each inductive load must include a protective device such as a peak limiter or a snubber. These relays do not support capacitive loads.

⚠ WARNING

RELAY OUTPUTS WELDED TO CLOSED POSITION

- Use a device or an external protection circuit suitable for all the relay outputs connected to alternating current inductive loads.
- Do not connect the relay outputs to capacitive loads.

Failure to follow these instructions can result in death, serious injury, or equipment damage.

Depending on the load a protection circuit may be required for device outputs and certain modules. Inductive load switching may create voltage impulses that damage, short-circuit or reduce the life of the output devices.

⚠ CAUTION

DAMAGE TO OUTPUT CIRCUITS DUE TO INDUCTIVE LOADS

Use an external protective device or circuit able to reduce the risks caused by voltage impulses in the switching of inductive loads.

Failure to follow these instructions can result in injury or equipment damage.

Choose a protection circuit from the following diagrams based on the electricity supply used. Connect the protection circuit outside the device or relay output module.

Two examples are given below:

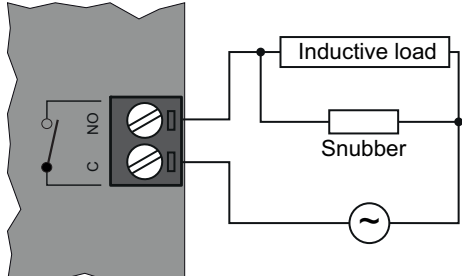
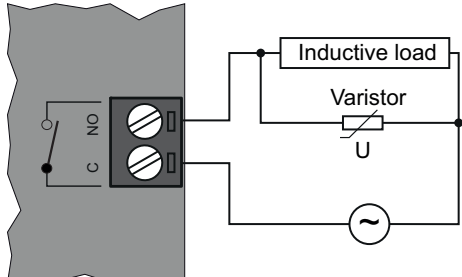
Protection circuit A	Protection circuit B
<p>This protection circuit uses a snubber and can be used for alternating current load circuits. The snubber must be compatible with the type of load and the RMS voltage of the snubber must be over that of the load by +10% (e.g. with a load running at 250 Vac, the snubber should have a minimum voltage of 275 Vac).</p> 	<p>This protection circuit uses a varistor and can be used for alternating current load circuits. In applications in which the inductive load is frequently and/or rapidly switched on and off, verify that the maximum continuous energy (J) of the varistor is 20% or more higher than the peak load energy and that the clamping voltage of the varistor is not lower than 1.6 times the load voltage.</p> 

Note: Place the protection devices as close as possible to the load.

Specific considerations for handling

When handling the equipment, take care to avoid damage caused by electrostatic discharge. In particular, the unshielded connectors are extremely vulnerable to electrostatic discharge.

⚠ WARNING
UNINTENDED EQUIPMENT OPERATION DUE TO ELECTROSTATIC DISCHARGE <ul style="list-style-type: none">• Keep the equipment in the protective packaging until ready for installation.• The device must only be installed in type-approved cupboards and/or in points that prevent unauthorized access and provide protection from electrostatic discharge.• When handling sensitive equipment, use a grounded device protecting against electrostatic discharge.• Before handling the equipment, always discharge the static electricity from the body by touching an earthed surface or type-approved antistatic mat. Failure to follow these instructions can result in death, serious injury, or equipment damage.

Before use, make sure that the device is connected to a suitable external electricity supply (refer to section **Power supply** and **Auxiliary EEV power supply**).

Handling the analog inputs-probes

The **temperature** (NTC, PTC, Pt1000) probes have no connection polarity and can be extended using a normal bipolar cable. Extension of the probes has a significant impact on the device in terms of electromagnetic compatibility EMC: pay great attention to the wiring.

The **ratiometric transducers** (0...5 V) and **pressure transducers** (4...20 mA), have a connection polarity.

⚠ WARNING
UNINTENDED EQUIPMENT OPERATION <ul style="list-style-type: none">• Make sure that the device is powered when power is supplied to other connected devices with an external power supply.• The signal cables (probes, digital inputs, communication, and relative power supplies) must be laid separately from the device power cables. Failure to follow these instructions can result in death, serious injury, or equipment damage.

NOTICE
INOPERABLE DEVICE <p>Before switching on the power supply, verify all the wiring connections.</p> Failure to follow these instructions can result in equipment damage.

Handling the electronic expansion valve

Before connecting the valve, configure the device carefully, selecting the type of valve from the list of valves that can be used (see parameter **E00**).

WARNING

UNINTENDED EQUIPMENT OPERATION

- Make sure the correct valve model is selected.
- Before using the valve, verify the parameters and the data provided by the valve manufacturer.

Failure to follow these instructions can result in death, serious injury, or equipment damage.

Always cut off the equipment electricity supply before carrying out any maintenance work on the electrical connections.

For correct connection, observe the following:

- Separate the cables for the probes and the digital inputs from inductive loads and dangerous voltage connections to avoid electromagnetic interference. Avoid positioning probe cables near other electrical equipment (switches, contactors, etc.).
- Reduce the length of the connections as much as possible and avoid coiling them around electrically connected parts.

Serial connections

The device has the following serial communication ports:

- 1 opto-isolated RS485 serial port for supervision
- 1 serial port for local Link² network connection
- 1 serial port for terminal (**KDEPlus**, **KDWPlus**, **KDT**, **KDX**) or **ECPlus** viewer connection

Verify the wiring when connecting the serial line. A connection error may cause incorrect operation or make the equipment unusable.

RS485 serial

- Use a special shielded "twisted-pair" cable for RS485 (e.g.: BELDEN cable, model 9842). When laying cables, follow the indications in standard EN 50174 for I.T. wiring. Take extra care to separate the data transmission circuits from the power lines.
- The length of the RS485 network, which can be connected directly to the device, is 1200 m (in accordance with ANSI TIA/EIA RS-485-A and ISO 8482:1987 (E)).
- Modbus protocol allows management of up to 247 devices.
- Single terminal block with 3 wires: use all 3 wires ("+" and "-" for the signal; "G" for 0 V signal grounding).
- The network should have BUS DAISY CHAIN topology and termination resistance of 120 Ω - 1/4 W between terminals "+" and "-" at each of the two ends of the BUS or enable those already provided on the controllers.

Do not communicate over the RS485 serial port if the UNICARD/DMI/Multi Function Key is connected and vice-versa.

NOTICE

INOPERABLE DEVICE

Only connect the RS485 serial port or the TTL (for UNICARD/DMI/Multi Function Key).

Failure to follow these instructions can result in equipment damage.

Note: When the DMI is connected to the device, valve closure will be forced.

Link² connection serial port

Use a special shielded "twisted-pair" cable for RS485 (e.g.: BELDEN cable, model 9842). When laying cables, follow the indications in standard EN 50174 for I.T. wiring.

NOTE: A maximum of 8 devices can be connected to a Link² network.

Terminal or echo viewer connection serial port

Use the cable supplied with the terminal (**KDEPlus**, **KDWPlus**, **KDT**, **KDX**) or viewer (**ECPlus**) for connection.

Where required, take extra care when cutting the 2 connectors for the cable supplied and when arranging the wires in sequence for subsequent connection to the device terminals.

Please refer to **Connections between the terminal and the viewer**.

Connectors

The **RTX 600 IV** device has a “Base board” and a “Top board”.
The I/O (Input/Output) and port labels are marked on the device nut.

Base board connectors

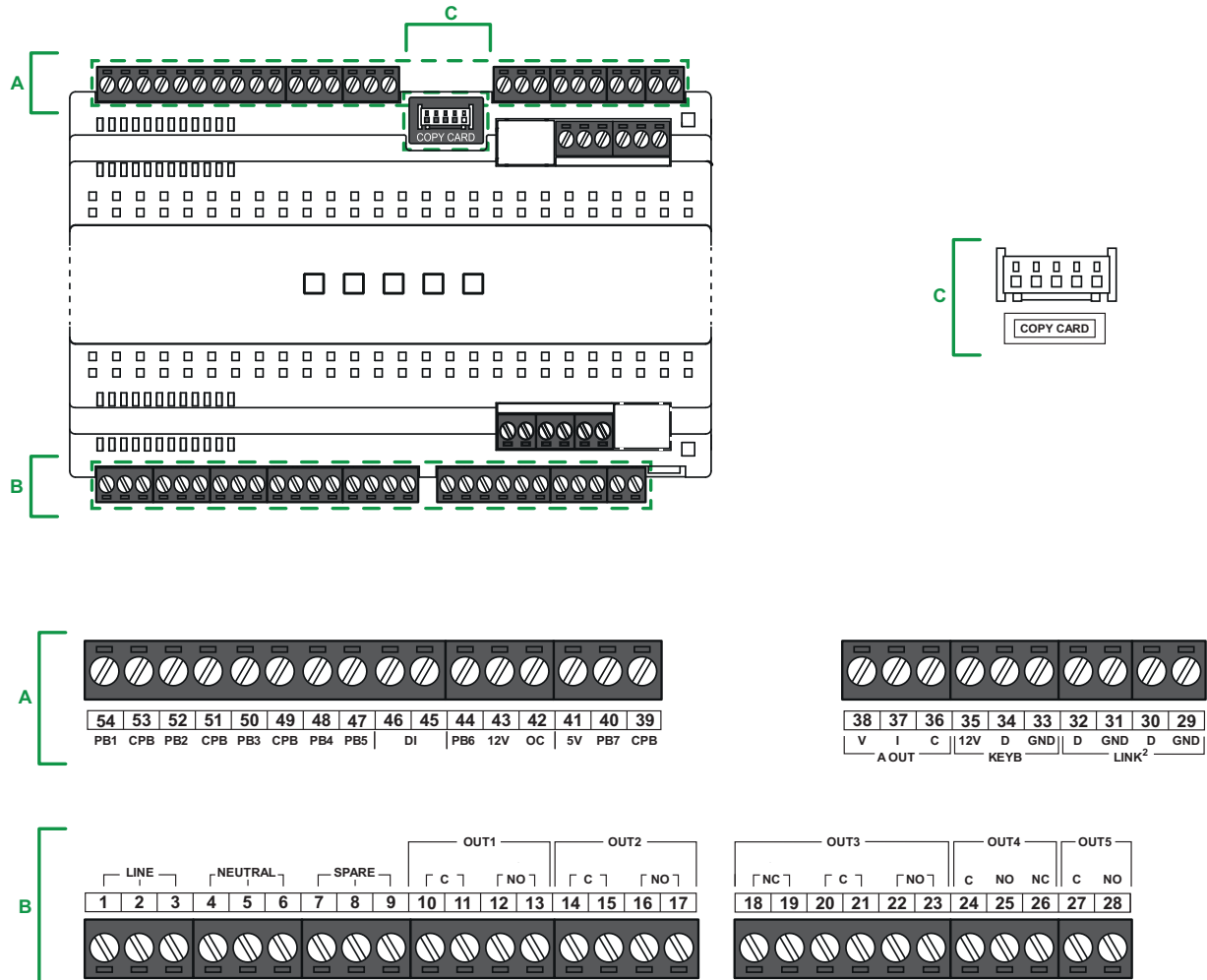

Top board connectors

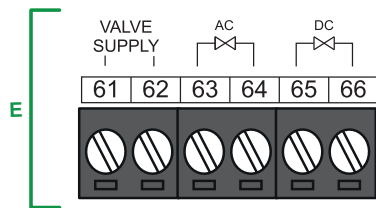
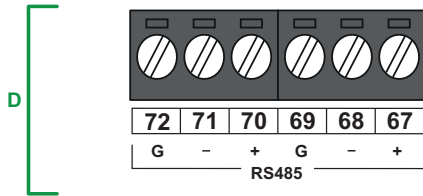
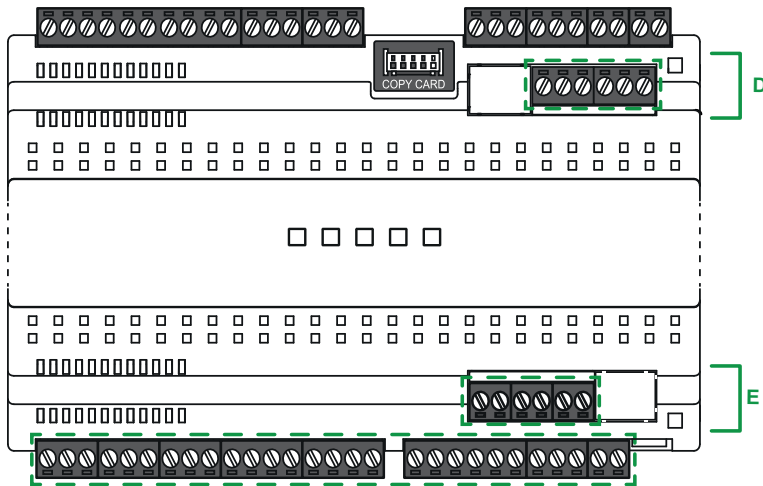

Wiring diagrams

Incorrect wiring causes irreversible damage to the device.

NOTICE

INOPERABLE DEVICE

Before switching on the power supply, verify all the wiring connections.

Failure to follow these instructions can result in equipment damage.

Base board wiring diagrams

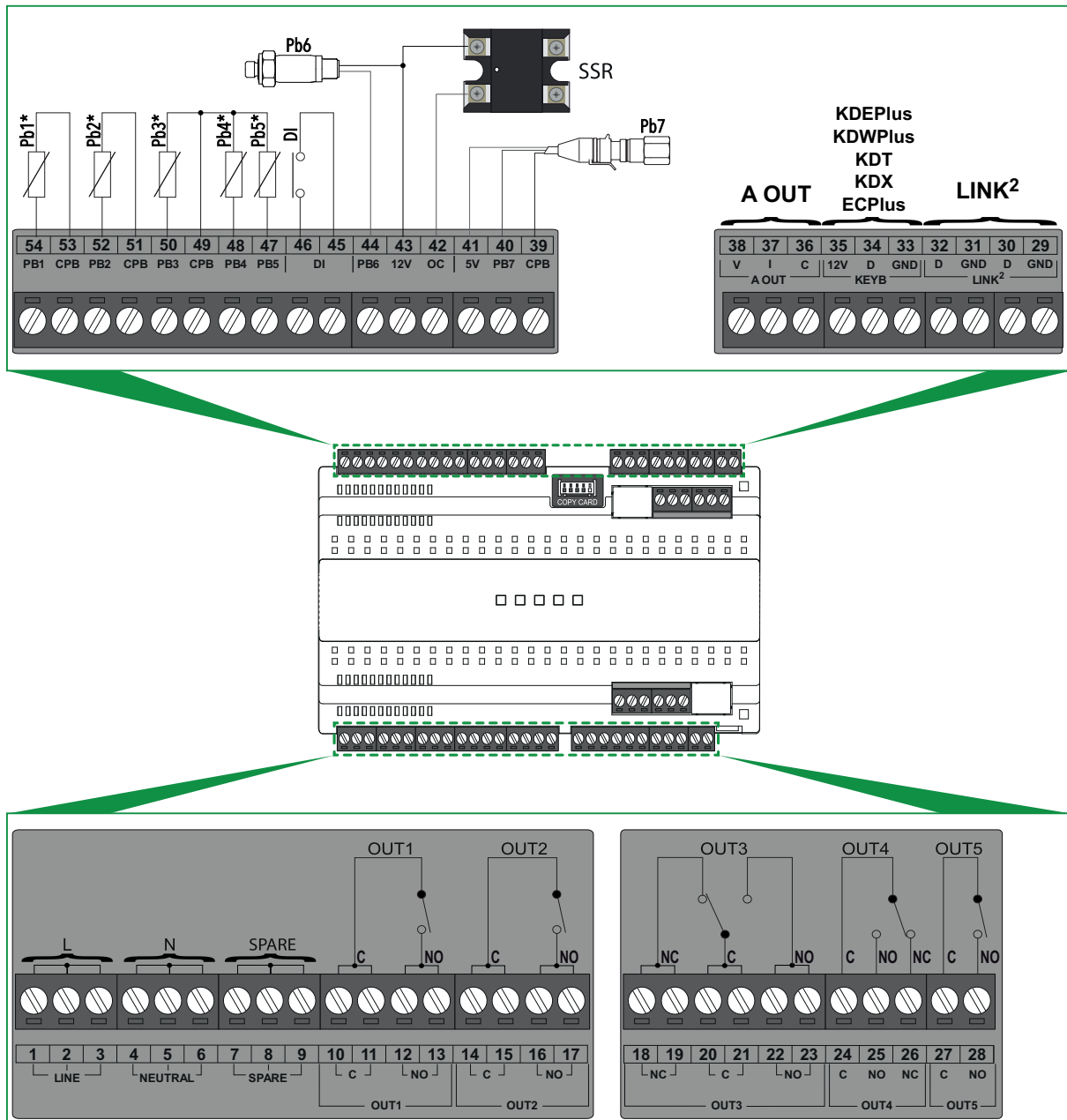

Label	Label	Terminal	Description	
Power supply	LINE	1-2-3	Power line	
	NEUTRAL	4-5-6	Power supply neutral	
	SPARE	7-8-9	Support terminals not connected internally	
Digital outputs	OUT1	C	10-11	OUT1 relay Common Terminal
		NO	12-13	OUT1 relay Normally Open
	OUT2	C	14-15	OUT2 relay Common Terminal
		NO	16-17	OUT2 relay Normally Open
	OUT3	NC	18-19	OUT3 relay Normally Closed
		C	20-21	OUT3 relay Common Terminal
		NO	22-23	OUT3 relay Normally Open
	OUT4	C	24	OUT4 relay Common Terminal
		NO	25	OUT4 relay Normally Open
		NC	26	OUT4 relay Normally Closed
OUT5	C	27	OUT5 relay Common Terminal	
	NO	28	OUT5 relay Normally Open	
Link2	LINK2-1	GND	31	0 V signal ground connection 1 - local network
		D	30	Signal connection 1 - local network
	LINK2-2	GND	31	0 V signal ground connection 2 - local network
		D	32	Signal connection 2 - local network
Terminal Connection	KEYB	GND	33	0 V signal ground
		D	34	External terminal data terminal
		12 V	35	+12 Vdc power supply output, external terminal power supply
DAC output	A OUT	c	36	Common Terminal
		I	37	Analog output under current (4...20 mA)
		V	38	Analog output under voltage (0...10 V)
Copy Card	TTL	---	UNICARD / DMI / Multi Function Key TTL connection	
PB6 - Ratiometric transducer	CPB	39	0 V signal ground	
	PB7	40	Ratiometric transducer connection (probe Pb7)	
	5 V	41	+5 Vdc power supply output for ratiometric transducer	
Open Collector Output	OC	42	Open Collector output (see parameters in FrH folder)	
	12 V	43	+12 Vdc power supply output for Open Collector output	
PB6 - Pressure transducer	12 V	43	+12 Vdc power supply output for pressure transducer	
	PB6	44	Pressure transducer connection (probe Pb6)	
Digital input	DI	45-46	Digital input	
Analog inputs	PB5	47	Analog input 5 (probe Pb5)	
	PB4	48	Analog input 4 (probe Pb4)	
	CPB	49	0 V signal ground analog inputs Pb3-Pb4-Pb5	
	PB3	50	Analog input 3 (probe Pb3)	
	CPB	51	0 V signal ground analog input 2	
	PB2	52	Analog input 2 (probe Pb2)	
	CPB	53	0 V signal ground analog input 1	
	PB1	54	Analog input 1 (probe Pb1)	

Note: For further information, refer to the **Technical Data** chapter.

Top board wiring diagrams

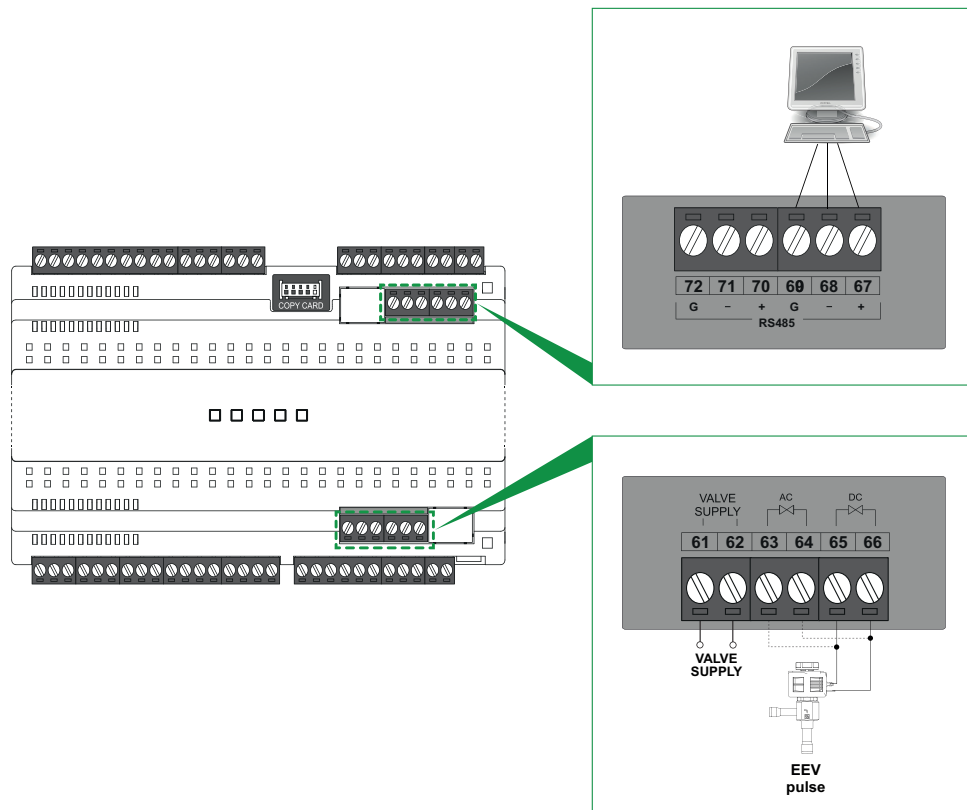

Label	Label	Terminal	Description
Pulse valve power supply	Valve Supply	61	Auxiliary power supply input for pulse electronic expansion valve. Refer to Auxiliary pulse EEV power supply .
		62	
Pulse valve output	AC	63	AC Valve connection terminals
		64	
	DC	65	DC Valve connection terminals
		66	
RS485-1	+	67	"+" signal for RS485-1 serial port
	-	68	"-" signal for RS485-1 serial port
	G	69	0 V signal ground
RS485-2	+	70	"+" signal for RS485-2 serial port
	-	71	"-" signal for RS485-2 serial port
	G	72	0 V signal ground

Note: For further information, refer to the **Technical Data** chapter.

Connecting Pulse EEV valves

Take extra care during the valve wiring stages. Choose the most suitable valve coil carefully in accordance with the voltage used.

⚠ WARNING

UNINTENDED EQUIPMENT OPERATION

Verify the information concerning valve parameters as declared by the manufacturer before using the valve in a generic valve configuration.

Failure to follow these instructions can result in death, serious injury, or equipment damage.

Schneider Electric and Eliwell are not responsible for data provided by the valve manufacturer, including technical changes or updates. Please refer to the product manual and the valve manual to verify its suitability and correct configuration.

NOTICE

INOPERABLE DEVICE

- Verify all wiring before engaging the electricity supply.
- Verify the rating data of the valve before connecting it.
- Make sure the valve coil is connected to the correct terminals.
- Make sure terminals 61-62 are connected to an AC power source with voltage of an RMS value suited to the type of valve used.

Failure to follow these instructions can result in equipment damage.

Note: The valve coil should be connected:

- to terminals 63-64 for valves in alternating current (AC)
- to terminals 65-66 for valves in direct current (DC).

Note: Connect terminals 61-62 to an AC power source with voltage of an RMS value:

- equal to the RMS value required by the valve coil if connected to an AC valve.
- equal to the DC value required by the valve coil if connected to a DC valve. For example, to control a valve with DC coil at 240 Vdc, you need to apply a voltage of 240 Vac RMS.

The wiring diagram for Pulse electronic expansion valves is as follows:

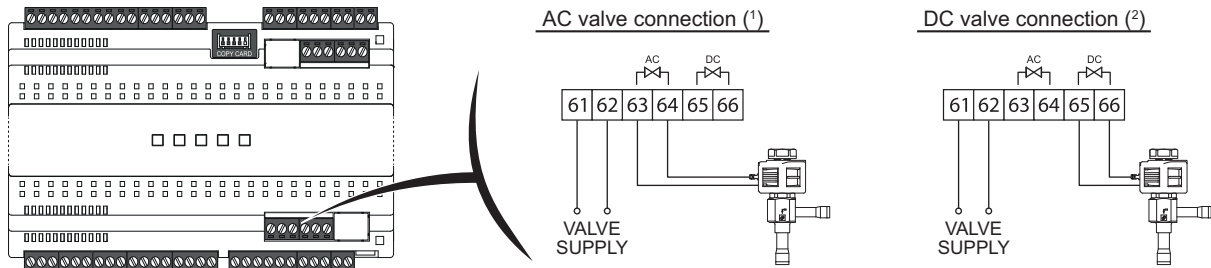

(1) = AC valve connection; (2) = DC valve connection

NOTE: The wiring diagrams described above also apply to the valves listed below. Manufacturer specifications are subject to change without notice.

Manufacturer	Valve	Reference document
DANFOSS	AKV10, AKV15, AKV20	DKRCC.PD.VA1.A7.02_AKV_sw.pdf
	AKVA (NH3)	DKRCC.PD.VA1.B5.02_AKVA.pdf
ALCO	EX2	EN_EX2__35016.pdf

Technical characteristics

Contents

This section includes the following topics:

- Introduction50
- Environmental and electrical characteristics 50
- Input characteristics51
- Output characteristics52
- Serial ports52
- Power supply53
- Auxiliary EEV power supply 53

Introduction

All components in the device system meet the European Community (CE) requirements for open devices.

They must be installed in a cabinet or other designated place to suit the environmental conditions and minimize the risk of involuntary contact with high voltages. Use metal casings to improve immunity to electromagnetic fields.

The application of incorrect current or voltage values at the analog inputs and outputs could damage the electronic circuits. Moreover, connection of a device current output to an analog input configured for voltage and vice-versa will also damage the electronic circuits.

NOTICE

INOPERABLE DEVICE

- Do not apply voltages over 11 V to the analog inputs of the device when the analog input is configured as a 0...5 V or 0...10 V input.
- Do not apply currents over 30 mA to the analog inputs of the device when the analog input is configured as an 0...20 mA or 4...20 mA input.
- Do not confuse the applied signal with the analog input configuration.

Failure to follow these instructions can result in equipment damage.

Environmental and electrical characteristics

Characteristics	Description
The product conforms to the following harmonized standards	EN 60730-1 and EN 60730-2-9
Device construction	Built-in electronic control device
Device purpose	Operating control (not safety) device
Type of action	1.C
Pollution class	2
Overvoltage category	II
Nominal pulse voltage	2500 V
Power supply	SMPS 100...240 Vac ($\pm 10\%$), 50/60 Hz
Auxiliary EEV power supply:	100...240 Vac ($\pm 10\%$) 50/60 Hz
Consumption (maximum)	7.5 W
Environmental operating conditions	Temperature: -5...55°C (23...131°F) Humidity: 10...90% RH (non-condensing)
Transportation and storage conditions	Temperature: -30...85°C (-22...185°F) Humidity: 10...90% RH (non-condensing)
Software class	A
Fuse	Certified according to IEC 60127-1; model: 5x20; value: 1 A fast - 250 V
Loads	See " Output characteristics "

If the nominal values within the specified temperature interval are not maintained, the device may operate incorrectly or become damaged and stop working altogether.

WARNING

UNINTENDED EQUIPMENT OPERATION

Do not exceed any of the rated values specified in the environmental and electrical characteristics table.

Failure to follow these instructions can result in death, serious injury, or equipment damage.

Input characteristics

The characteristics relating to the device inputs are as follows:

Characteristics	Description
Display ranges:	-99.9...99.9 or -999...999
Measuring range:	<ul style="list-style-type: none"> • NTC: -50...110°C (-58...230°F) • PTC: -55...150°C (-67...302°F) • Pt1000: -60...150°C (-76...302°F)
Display:	3 digits + sign
Accuracy:	<ul style="list-style-type: none"> • $\pm 1.0^{\circ}\text{C}/^{\circ}\text{F}$ for temperatures under -30.0°C (-22.0°F) • $\pm 0.5^{\circ}\text{C}/^{\circ}\text{F}$ for temperatures between -30.0°C...25.0°C (-22.0°C...77.0°F) • $\pm 1.0^{\circ}\text{C}/^{\circ}\text{F}$ for temperatures over 25°C (77°F)
Resolution:	1 or 0.1°C/°F
Analog / Digital inputs:	<ul style="list-style-type: none"> • Pb1: configurable NTC / PTC / Pt1000 / DI input • Pb2: configurable NTC / PTC / Pt1000 / DI input • Pb3: configurable NTC / PTC / Pt1000 / DI input • Pb4: configurable NTC / PTC / Pt1000 / DI input • Pb5: configurable NTC / PTC / Pt1000 / DI input • Pb6: configurable 4...20 mA / DI input • Pb7: configurable ratiometric / DI input • DI: multifunctional voltage free digital input

Analog inputs configured as digital inputs are not isolated.

NOTICE
<p>INCORRECT INPUT WIRING ON NON-ISOLATED INPUTS</p> <p>Only use voltage-free inputs on analog inputs configured as digital inputs.</p> <p>Failure to follow these instructions can result in equipment damage.</p>

Note: the technical characteristics provided in this document concerning measurement (range, accuracy, resolution, etc.) refer to the instrument itself only and not to any accessories supplied, such as the probes.

Output characteristics

The characteristics relating to the device outputs are as follows:

Characteristics	Description	EU 60730 (230 Vac maximum)	USA 60730 (230 Vac maximum)
Digital outputs:	OUT1 (SPST):	NO 12(5) A	NO: 12A resistive, 5FLA 30LRA
	OUT2 (SPST):	NO 12(5) A	NO: 12A resistive, 5FLA 30LRA
	OUT3 (SPDT):	NO 12(5) A NC 12 A resistive	NO: 12A resistive, 5FLA 30LRA NC: 12A resistive
	OUT4 (SPDT):	NO 8(4) A - NC 6(3) A	NO: 8A resistive, 4.9FLA 29.4LRA NC: 6A resistive
	OUT5 (SPST):	NO 8(4) A	NO: 8A resistive, 4.9FLA 29.4LRA
OC (Open Collector) Output:	OC: 1 multifunction output: 12 Vdc - 20 mA		
DAC output:	A OUT: 1 multifunction output: 0...10 Vdc / 4...20 mA		
Pulse EEV driver output:	AC/DC: 1 SSR relay 100...240 Vac/dc; maximum I = 300 mA		

Serial ports

The mechanical characteristics of the device inputs are as follows:

Serial	Description	Notes
TTL	1 TTL serial port	Connection between the device and accessories for quick programming UNICARD, Multi Function Key (MFK) and Device Manager (via DMI)
RS485	1 split RS485 serial port	If the device is connected to the RS485 communication line, apply a 120 Ω termination resistor between line "+" and line "-" of the RS485
LINK ²	1 split Link ² serial port	Connection of several controllers (up to 8) forming a local network
KEYB	1 serial port per terminal	<ul style="list-style-type: none"> • Connection between the device and the external terminal KDEPlus, KDWPlus, KDT or KDX • Connection between the device and the viewer ECPlus

For further information, please refer to "Serial connections" on page 29.

Take extreme care with the connection of serial lines. Incorrect wiring could prevent the device from working.

Do not communicate over the RS485 serial port if the UNICARD / DMI / MFK is connected and vice-versa.

NOTICE

INOPERABLE DEVICE

Only connect the RS485 serial port or the TTL (for UNICARD/DMI/Multi Function Key).

Failure to follow these instructions can result in equipment damage.

Power supply

The device can be powered with a voltage of 100...240 Vac ($\pm 10\%$) 50/60 Hz.

Depending on the requirements of individual units and/or the country of installation, if the country's mains voltage is within the operating range, the device can be connected directly to the mains power supply.

Auxiliary EEV power supply

Choose the most suitable valve coil carefully in accordance with the voltage used.

Schneider Electric and Eliwell are not responsible for data provided by the valve manufacturer, including technical changes or updates. Please refer to the product manual and the valve manual to verify its suitability and correct configuration.

NOTICE

INOPERABLE DEVICE

- Verify all wiring before engaging the electricity supply.
- Verify the rating data of the valve before connecting it.
- Make sure the valve coil is connected to the correct terminals.
- Make sure terminals 61-62 are connected to an AC power source with voltage of an RMS value suited to the type of valve used.

Failure to follow these instructions can result in equipment damage.

Note: The valve coil should be connected:

- to terminals 63-64 for valves in alternating current (AC)
- to terminals 65-66 for valves in direct current (DC).

Note: Connect terminals 61-62 to an AC power source with voltage of an RMS value:

- equal to the RMS value required by the valve coil if connected to an AC valve.
- equal to the DC value required by the valve coil if connected to a DC valve. For example, to control a valve with DC coil at 240 Vdc, you need to apply a voltage of 240 Vac RMS.

User interface and operation

Contents

This section includes the following topics:

KDEPlus Terminal	55
KDWPlus Terminal	56
KDT Terminal (Vertical and Horizontal)	57
KDX Terminal	59
Device connection with terminal and/or viewer	61
Using the device	63
"Machine Status" Menu	66
`Programming" menu	67
Setting and calibrating the probes	68
Setting the displayed values	68

KDEPlus Terminal

Interface



Keys

Key	press and release	press for at least 5 seconds
	<ul style="list-style-type: none"> Scroll through the menu options Increase the values 	From outside the menus only. Can be configured by the user (parameter H31). Default: Manual defrost (H31 = 1).
	<ul style="list-style-type: none"> Scroll through the menu options Decrease the values 	From outside the menus only. Can be configured by the user (parameter H32). Default: not configured (H32=0).
	<ul style="list-style-type: none"> Go back up one level in the menu Confirm the parameter value 	From outside the menus only. Can be configured by the user (parameter H33). Default: Stand-by (H33=6).
	<ul style="list-style-type: none"> Access the "Machine Status" menu Display alarms (if present) Confirm commands 	<ul style="list-style-type: none"> Access the "Programming" menu When switching on, access selection mode for the application AP1...AP8 to be loaded.

Icons

Icon	Function	Description
	Compressor	On steadily: compressor active Flashing: delay, protection or activation inhibited Off: compressor off
	Defrost	On steadily: defrost active Flashing: defrost activated manually or via digital input Off: defrost inactive
	Evaporator fans	On steadily: fans active Off: fans off
	Energy saving	On steadily: Energy saving active Flashing: reduced set active Off: Energy Saving not active
	Alarm	On steadily: alarm present Flashing: alarm silenced Off: No alarm active
	°F	On steadily: setting in °F (dro (1) = F) Flashing: terminal shared on Link ² Off: light off
	AUX	On steadily: AUX output active and/or light on Flashing: Deep cooling active Off: AUX output off
	°C	On steadily: setting in °C (dro (0) = C) Flashing: terminal shared on Link ² Off: a value not relating to temperature or a label is displayed

KDWPlus Terminal

Interface

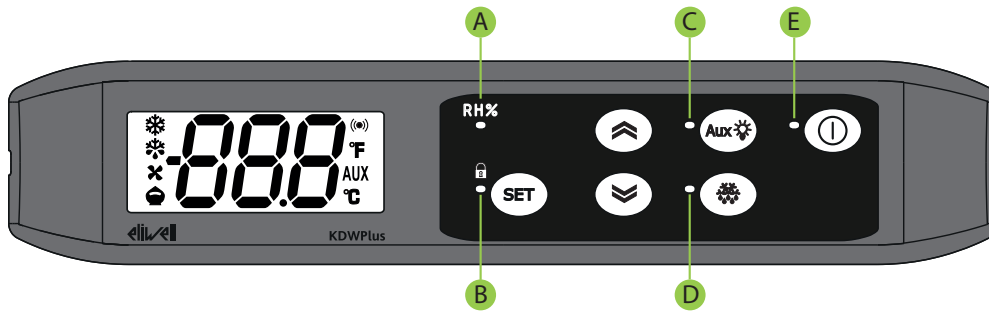

Keys





Key	press and release	press for at least 5 seconds
	<ul style="list-style-type: none"> Scroll through the menu options Increase the values 	From outside the menus only. Can be configured by the user (parameter H31). Default: Manual defrost (H31 = 1). Change to H31=0 .
	<ul style="list-style-type: none"> Scroll through the menu options Decrease the values 	From outside the menus only. Can be configured by the user (parameter H32). Default: Not configured (H32 = 0).
	<ul style="list-style-type: none"> Go back up one level in the menu Confirm the parameter value 	From outside the menus only. Can be configured by the user (parameter H33). Default: Stand-by (H33=6).
	<ul style="list-style-type: none"> Access the "Machine Status" menu Display alarms (if present) Confirm commands 	<ul style="list-style-type: none"> Access the "Programming" menu When switching on, access selection mode for the application AP1...AP8 to be loaded
	Activate/deactivate the Manual Defrost function	From outside the menus only. Can be configured by the user (parameter H35). Default: Activate stand-by (H35=6). Change to H35=1 .
	Activate the AUX output / Switch on the light	From outside the menus only. Can be configured by the user (parameter H34). Default: Light (H34=3).

Icons

Icon	Function	Description
	Compressor	On steadily: compressor active Flashing: delay, protection or activation inhibited Off: compressor off
	Defrost	On steadily: defrost active Flashing: defrost activated manually or via digital input Off: defrost inactive
	Evaporator fans	On steadily: fans active Off: fans off
	Energy saving	On steadily: Energy saving active Flashing: reduced set active Off: Energy Saving not active
	Alarm	On steadily: alarm present Flashing: alarm silenced Off: No alarm active
	°F	On steadily: setting in °F (dro (1) = F) Flashing: terminal shared on Link ² Off: light off

Icon	Function	Description
AUX	AUX	On steadily: AUX output active and/or light on Flashing: Deep cooling active Off: AUX output off
°C	°C	On steadily: setting in °C (dro (0) = C) Flashing: terminal shared on Link ² Off: a value not relating to temperature or a label is displayed

LED





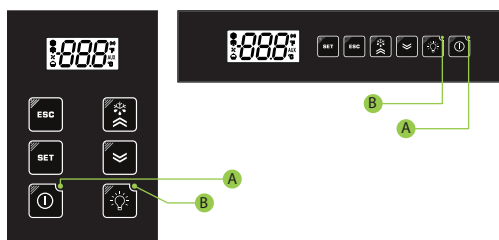

Nr	Function	Description
A	RH%	Forced Fan activation (if H1x or i1y = 15 with x = 1...8 and y = 1 or 2)
B		Terminal locked
C	Aux 	Light relay activation via key
D		Defrost active
E		Device off

KDT Terminal (Vertical and Horizontal)









Interface





Keys

Key	press and release	press for at least 5 seconds
	<ul style="list-style-type: none"> Go back up one level in the menu Confirm the parameter value 	From outside the menus only. Can be configured by the user (parameter H33). Default: Stand-by (H31=1).
	<ul style="list-style-type: none"> Access the "Machine Status" menu Display alarms (if present) Confirm commands 	<ul style="list-style-type: none"> Access the "Programming" menu When switching on, access selection mode for AP1...AP8 to be loaded
	---	From outside the menus only. Can be configured by the user (parameter H35). Default: Stand-by (H35=6).
	<ul style="list-style-type: none"> Scroll through the menu options Increase the values 	From outside the menus only. Can be configured by the user (parameter H31). Default: Manual defrost (H31 = 1).
	<ul style="list-style-type: none"> Scroll through the menu options Decrease the values 	From outside the menus only. Can be configured by the user (parameter H32). Default: Not configured (H32 = 0).
	Switch the light on/off	From outside the menus only. Can be configured by the user (parameter H34). Default: Light (H34=3).
	Activate remote display function (terminal shared on LINK ²)	

Icons

Icon	Function	Description
	Compressor	On steadily: compressor active Flashing: delay, protection or activation inhibited Off: compressor off
	Defrost	On steadily: defrost active Flashing: defrost activated manually or via digital input Off: defrost inactive
	Evaporator fans	On steadily: fans active Off: fans off
	Energy saving	On steadily: Energy saving active Flashing: reduced set active Off: Energy Saving not active
	Alarm	On steadily: alarm present Flashing: alarm silenced Off: No alarm active
	°F	On steadily: setting in °F (dro (1) = F) Flashing: terminal shared on Link ² Off: light off
	AUX	On steadily: AUX output active and/or light on Flashing: Deep cooling active Off: AUX output off
	°C	On steadily: setting in °C (dro (0) = C) Flashing: terminal shared on Link ² Off: a value not relating to temperature or a label is displayed

LED

Nr	Function	Description
A		Device off.
B		Light relay activation via key.

KDX Terminal



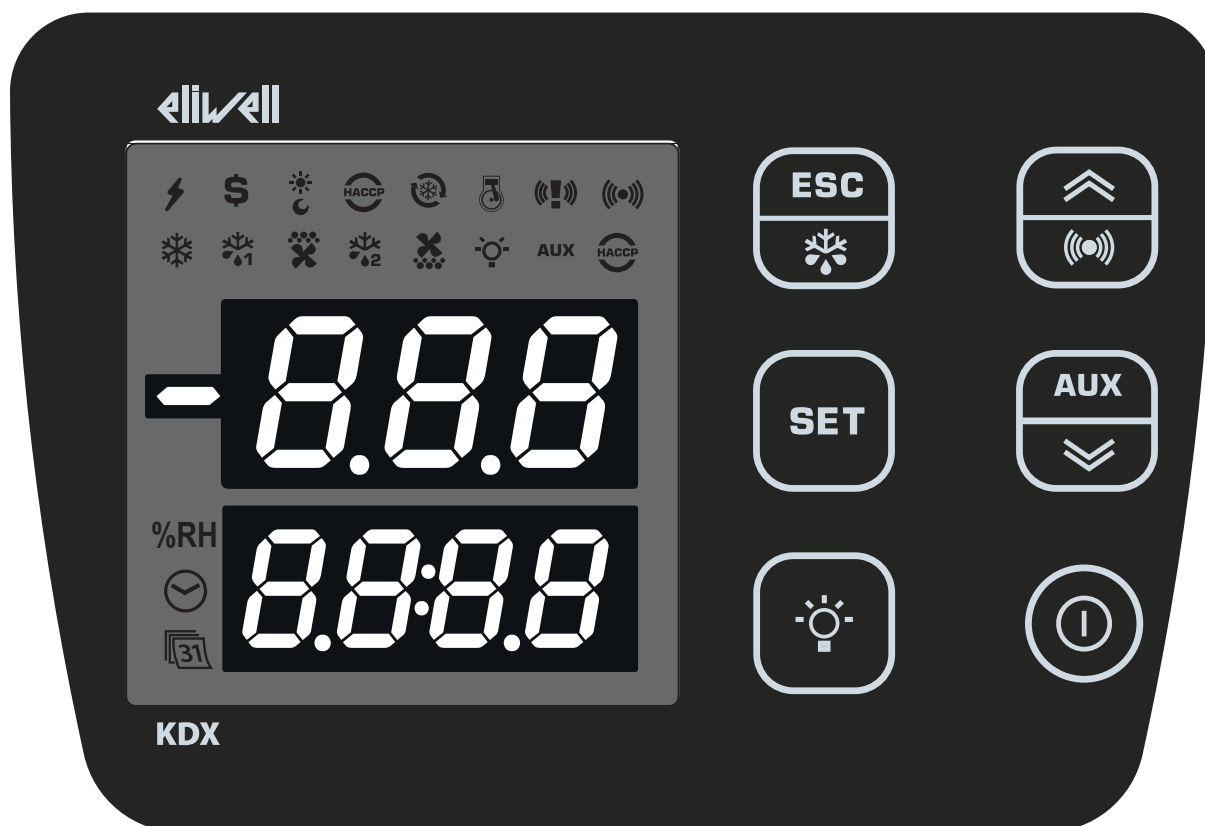













Interface



Keys

Key	press and release	press for at least 3 seconds
	<ul style="list-style-type: none"> Go back up one level in the menu Confirm the parameter value 	From outside the menus only. Can be configured by the user (parameter H33). Default: Stand-by (H33=6). Change to H33=1 (defrost)
	<ul style="list-style-type: none"> Access the "Machine Status" menu Display alarms (if present) Confirm commands 	<ul style="list-style-type: none"> Access the "Programming" menu When switching on, access selection mode for the application AP1...AP8 to be loaded
	Switch the light on / off	From outside the menus only. Can be configured by the user (parameter H34). Default: Light (H34=3).
	<ul style="list-style-type: none"> Scroll through the menu options Increase the values 	<ul style="list-style-type: none"> From outside the menus only. Can be configured by the user (parameter H31). Default: Manual defrost (H31 = 1). Change to H31=0. Alarm acknowledgment
	<ul style="list-style-type: none"> Scroll through the menu options Decrease the values 	From outside the menus only. Can be configured by the user (parameter H32). Default: Not configured (H32 = 0). Change to H32=5 (AUX).
	Device Stand-by	<ul style="list-style-type: none"> Switch device on / off. From outside the menus only. Can be configured by the user (parameter H35). Default: Stand-by (H35=6).

Icons

Icon	Color	Function	Description
	Green	Power supply	On steadily: power supply present Off: power supply absent
	Amber	Reduced setpoint	On steadily: reduced setpoint enabled Off: reduced setpoint not enabled
	Amber	Energy saving	On steadily: energy saving enabled Off: energy saving not enabled
	NOT USED		
	Amber	Deep Cooling (DCC)	On steadily: deep cooling cycle enabled Off: deep cooling cycle not enabled
	NOT USED		
	Red	Leak Detector Alarm Panic Alarm	On steadily: panic and/or leak detector alarm active Flashing: leak detector pre-alarm active Off: no alarm
	Red	Alarm	On steadily: alarm active Flashing: alarm acknowledged Off: no alarm
	Amber	Compressor	On steadily: compressor active Flashing: compressor activation delay Off: compressor not active
	Amber	Defrost 1	On steadily: defrost 1 active Flashing: dripping 1 active Off: no defrost
	Amber	Evaporator fans	On steadily: evaporator fans active Flashing: forced ventilation Off: evaporator fans off
	Amber	Defrost 2	On steadily: defrost 2 active Flashing: dripping 2 active Off: no defrost
	NOT USED		
	Amber	Light	On steadily: light on Off: light off
AUX	Amber	Auxiliary (AUX)	On steadily: auxiliary output active Off: auxiliary output off
	NOT USED		
%RH	NOT USED		
	NOT USED		
	NOT USED		

Device connection with terminal and/or viewer

Introduction

A single **KDEPlus**, **KDWPlus**, **KDT** (Vertical or Horizontal) terminal or **KDX** including an **ECPlus** viewer can be connected for remote display purposes.

Connection with KDEPlus and ECPlus

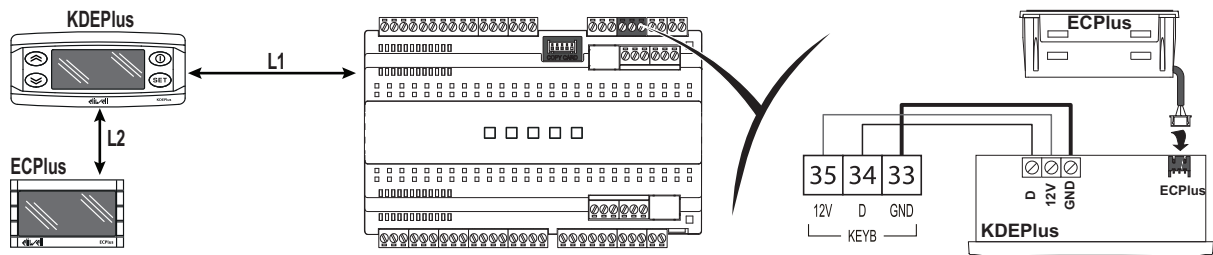

Legend: L1 = maximum 15 m / 49.21 ft; L2 = maximum 85 m / 278.87 ft

Connection with KDWPlus and ECPlus

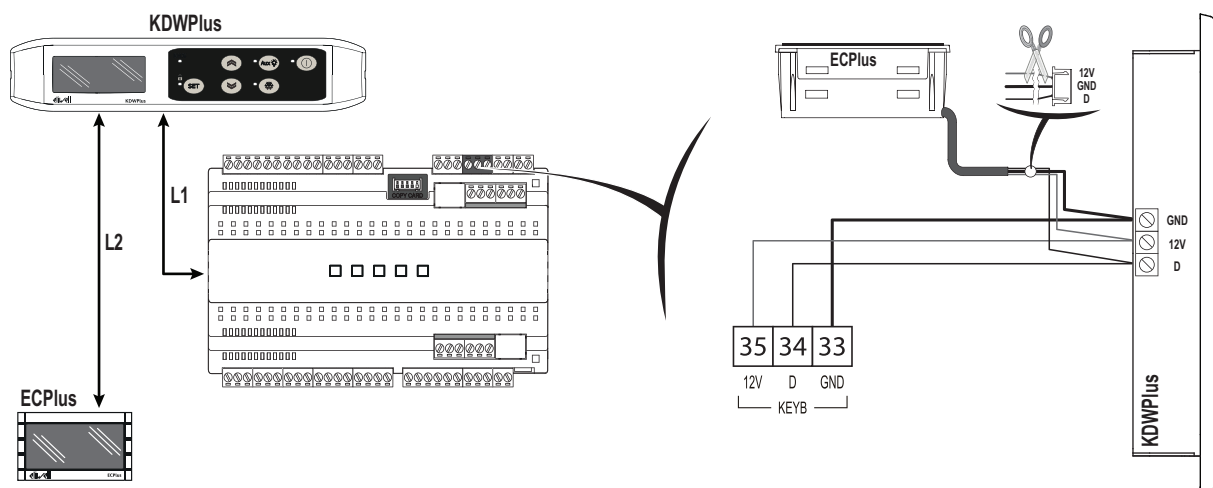

Legend: L1 = maximum 15 m / 49.21 ft; L2 = maximum 85 m / 278.87 ft

Note: An **ECPlus** module can be connected to the **KDWPlus** on the same terminal to which the base is connected.

Connection with KDT (Vertical or Horizontal)

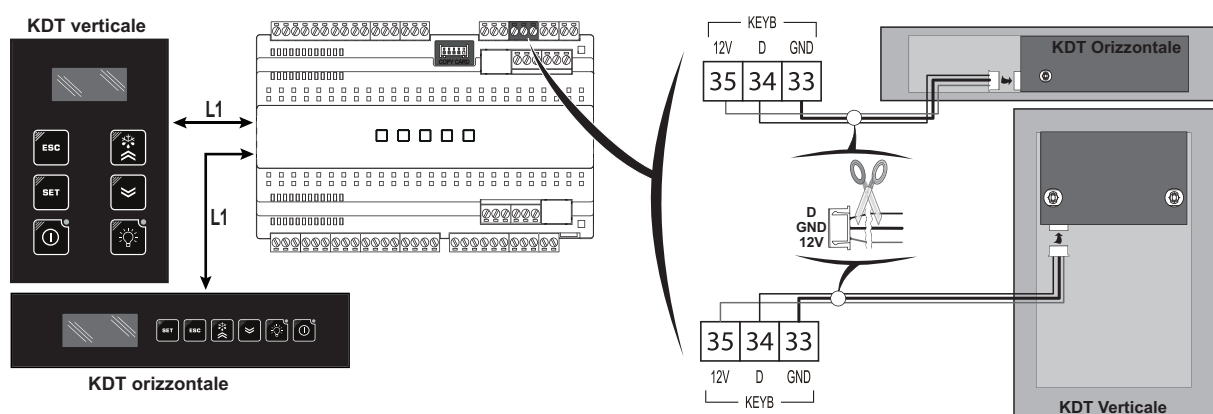

Legend: L1 = maximum 100 m / 328.08 ft.

Connection with KDX

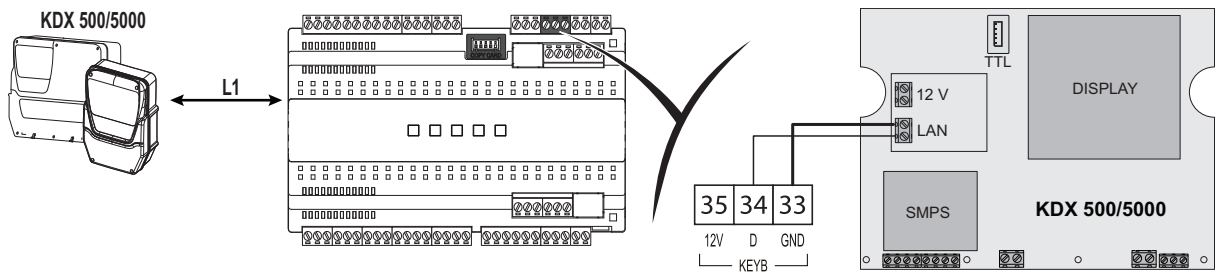

Legend: L1 = maximum 100 m / 328.08 ft.

Connection with ECPlus

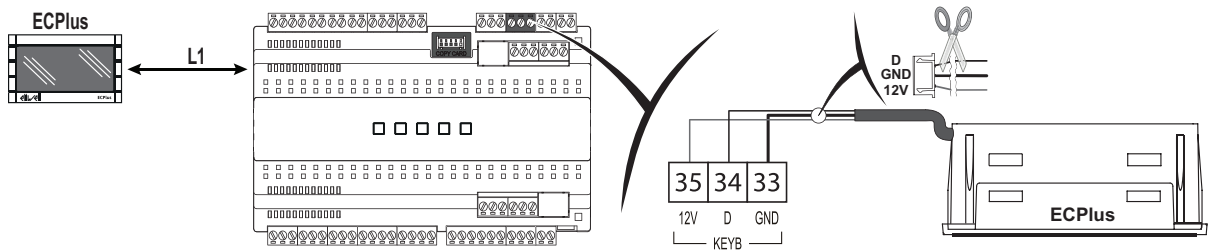

Legend: L1 = maximum 100 m / 328.08 ft.

Using the device

Switching on for the first time

Once the electrical connections have been completed, simply power up the device for it to start working. At the first startup:

1. Select and load the preset application - **AP1...AP8** - that best reflects the usage requirements.
2. Verify and, if necessary, adjust the value of the main device parameters to adapt the selected application to your system.
3. Make sure there are no active alarms (see alarms section).

Loading Preset Applications

The procedure for loading one of the preset applications is:

1. Switch on the terminal connected to the device; press and hold **SET** until label "AP1" appears.
Note: On the **KDT** terminal, within 30 seconds of switching the device on, press and hold any button for a least 1 second to unlock the terminal and then press and hold **▲** and **▼** simultaneously until label "AP1" appears.
Note: On the **KDX** terminal, within 30 seconds of switching the device on, press **▲** and **▼** simultaneously until label "AP1" appears.
2. Scroll through applications **AP1...AP8** using **▲** and **▼**
3. Confirm the selected preset application using **SET**.
Note: The process can be canceled by pressing **ESC** or letting a timeout occur (15 seconds)
4. If the procedure was completed successfully, the display will show "yES"; otherwise it will show "Err"
5. The device will restart and revert to showing the main display

The procedure for loading one of the preset applications restores the respective default values, with the exception of the parameters **NON** specific to the application that retain the value set previously. These values, left unaltered, may not be suitable and may therefore need to be changed.

NOTICE

INOPERABLE DEVICE

Verify the parameters after loading a preset application.

Failure to follow these instructions can result in equipment damage.

Setting the setpoint

1. **KDT terminals only:** press any key for at least 1 second to unlock the terminal
2. Press and release **SET** to access the "Machine status" menu
3. Scroll through the folders with **▲** and **▼** until you find the folder **SEt**
4. Press **SET** to view the current setpoint value.
5. Change the setpoint value using **▲** and **▼** within 15 seconds.
6. To confirm the value press **SET** or **ESC**, or let a timeout occur (15 seconds).

Locking/unlocking the terminal

The terminal can be locked/unlocked by programming the parameter **LOC** as required.

If the terminal is locked, it is possible to access the "Machine status" menu by pressing the key **SET** and view the Setpoint, but the value cannot be changed. To unlock the terminal, repeat the procedure used for locking it

The terminal only locks automatically on **KDT**:















- on startup
- after 30 seconds of inactivity

Password

The passwords **PA1** and **PA2** are required to access the device parameters:

- **PA1**: access the User parameters (default: **PA1** = 0 - disabled)
- **PA2**: access the Installer parameters (default: **PA2** = 15 - enabled)

To change the password value:





1. Press and hold for at least 5 seconds 
2. Scroll through the parameters with  and  until you find the label "PA2"
3. Press and release 
4. Set the value "15" using the keys  and 
5. Confirm the value by pressing  (the first folder will be displayed)
6. Scroll through the folders with  and  until you find the label "diS"
7. Press and release 
8. Scroll through the parameters with  and  until you find the label "PS1" or "PS2", depending on whether you want to change access password **PA1** or **PA2**
9. To confirm the value press  or , or let a timeout occur (15 seconds).

The visibility of **PA2** is:

- **PA1≠0 and PA2≠0**: **PA1** and **PA2** will be shown. It is then possible to decide whether to directly access the "User" parameters (label "PA1") or the Installer parameters (label "PA2").
- **Otherwise**: Password **PA2** will be displayed following level 1 parameters. If enabled, it will be requested in order to access the "Installer" parameters.

Note: If the value entered is incorrect, the label **PA1/PA2** will be shown again. Repeat the procedure.

Viewing the probe values



















1. **KDT terminal only**: press any key for at least 1 second to unlock the terminal
2. Press and release  to access the "Machine status" menu
3. Scroll through the folders with  and  until you find the folder **Pb1...Pb7**
4. Press  to view the value measured by the corresponding probe.

Notes: the displayed value cannot be changed.

Setting frequently used functions

Some frequently used functions may be paired with the keys by suitably configuring the corresponding parameters; they can then be activated by pressing and holding the paired key.

Note: some keys may not be present, depending on the model.

Key				Parameter
KDEPlus	KDWPlus	KDT	KDX	
				H31
				H32
				H33
---				H34
---				H35

Value H31/H32/H33/H34/H35	Description
0	Disabled
1	Defrost
2	Reduced Set
3	Light
4	Energy Saving
5	AUX
6	Stand-by
7	Deep Cooling Cycle
8	Defrost start/end
9	Counter cleaning function

Setting the main parameters

See "User" menu in the parameters table for the various models.

"Machine Status" Menu

Introduction

Press and release **SET** to access the "Machine status" menu.

Menu

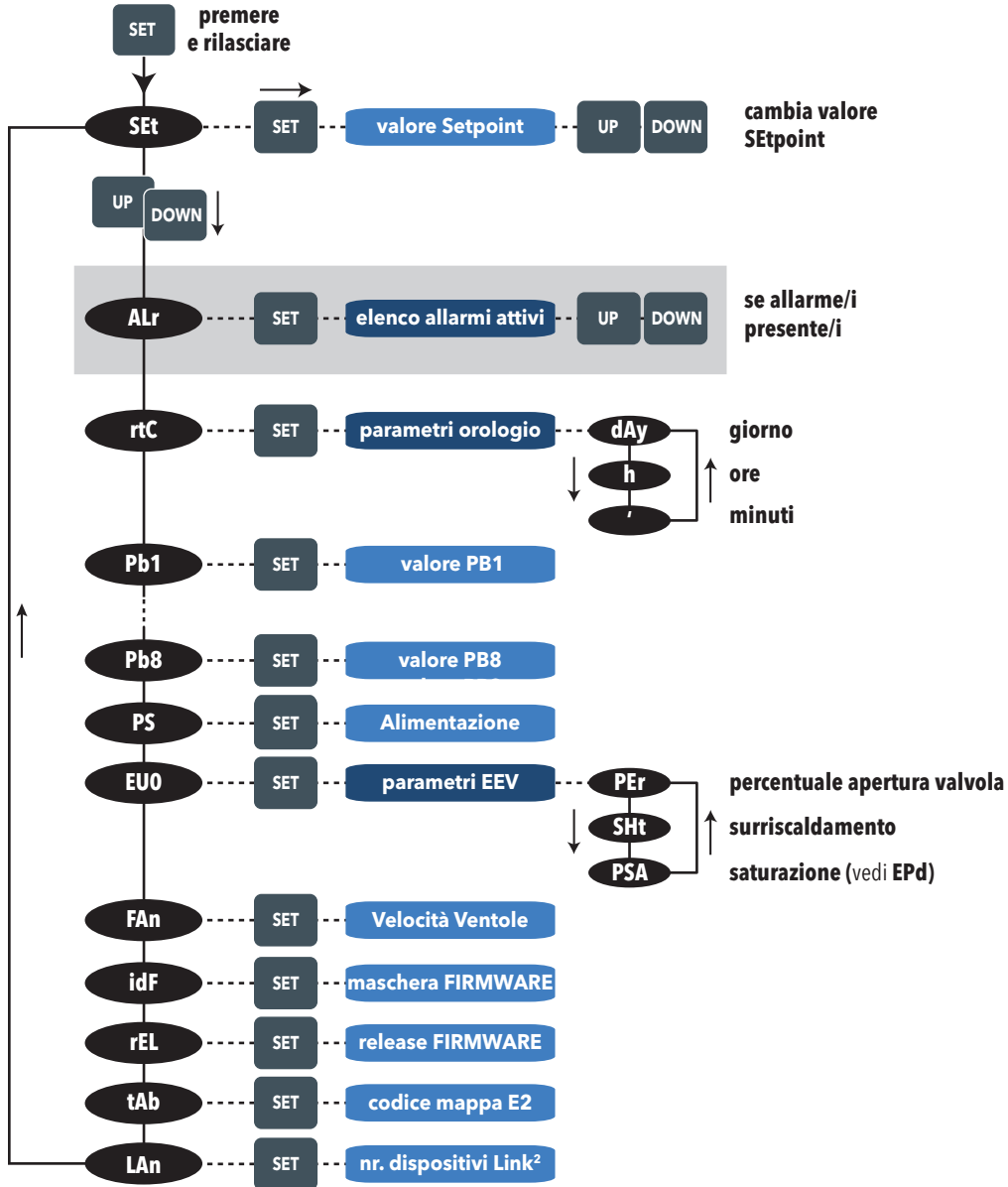

‘Programming’ menu

Introduction

Press and hold **SET** for at least 5 seconds to access the “Programming” menu.
 If required, an access password **PA1** for “User” parameters or **PA2** for “Installer” parameters will be requested (see section “Passwords”).

Note: Switch the device off and on again every time you change the parameter configuration.

Menu

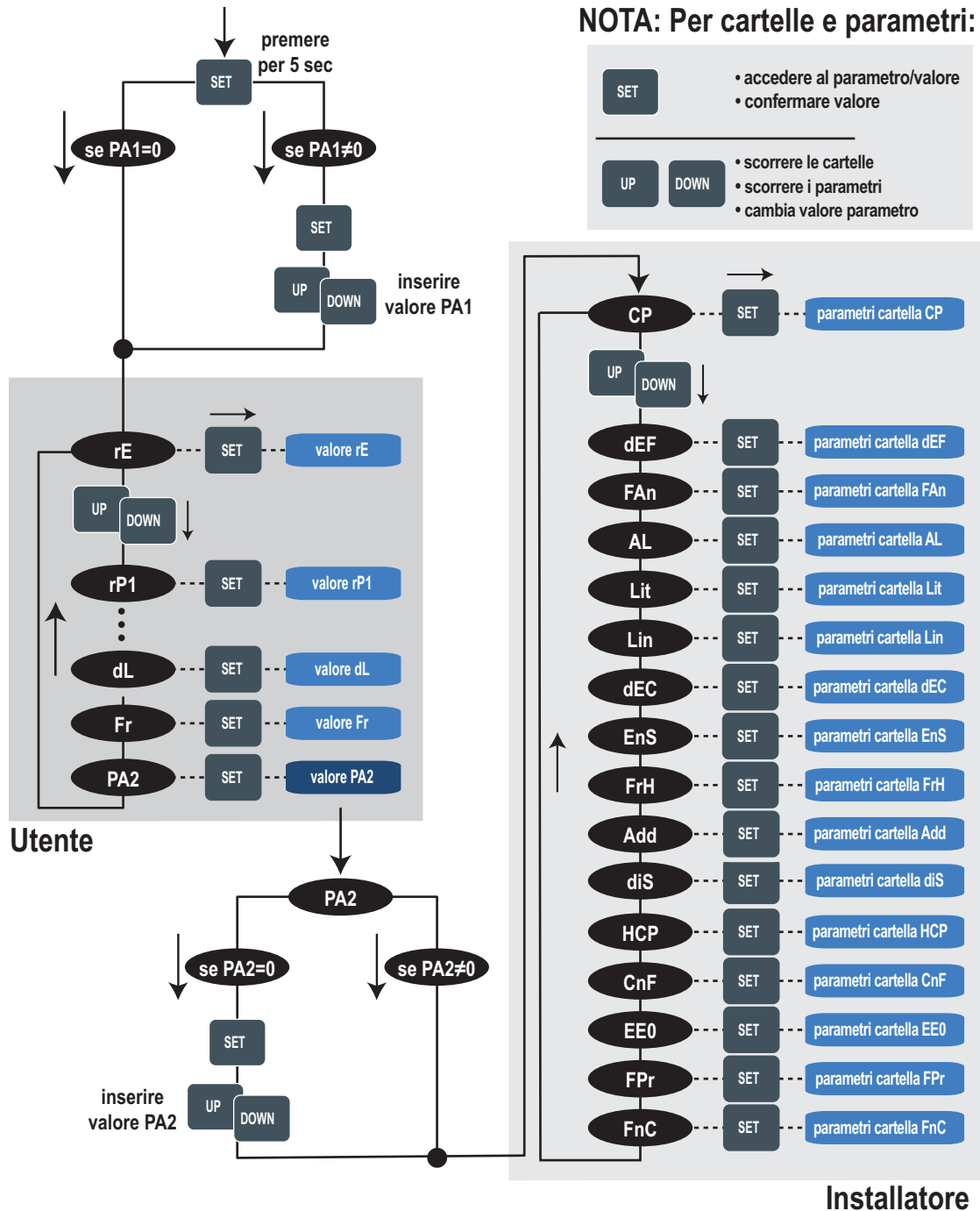

Setting and calibrating the probes

Probe inputs

The device has the following inputs:

- 5 NTC / PTC / Pt1000 / DI inputs (**Pb1**, **Pb2**, **Pb3**, **Pb4** and **Pb5**)
- 1 4...20 mA / DI input (**Pb6**)
- 1 ratiometric / DI input (**Pb7**)

Note: The temperature probes (**Pb1...Pb5**) must all be of the same type.

Setting the probe type

To configure the temperature probes (**Pb1...Pb5**), you need to set parameter **H00** at **User** level or in folder **CnF** within the "Installer" menu:

H00 value	Probe type
ntc (0) (default)	NTC
Ptc (1)	PTC

Probe calibration

The **diS** folder, within the "Installer" menu, contains the parameters

- **CA1** (probe Pb1)
- **CA2** (probe Pb2)
- **CA3** (probe Pb3)
- **CA4** (probe Pb4)
- **CA5** (probe Pb5)
- **CA6** (probe Pb6)
- **CA7** (probe Pb7)

to force an additional value (with sign) on reading the corresponding probe (if managed by the specific model).

Setting the displayed values

Introduction

The following settings refer to the parameters in folder **diS**.

Display with decimal point

You need to set parameter **ndt**:

ndt value	Description
no (0)	Display with no decimal point
yes (1)	Display with decimal point and resolution to tenths of a degree

Note: this setting only influences the displaying of data, not the resolution of the measurement or the accuracy of the device's calculations.

Default display

You need to set parameter **ddd**:

ddd value	Description
SP1 (0)	Display setpoint
Pb1 (1)	Display the value read by Pb1
Pb2 (2)	Display the value read by Pb2
Pb3 (3)	Display the value read by Pb3
Pb4 (4)	Display the value read by Pb4
Pb5 (5)	Display the value read by Pb5
Pbi (6)	Display the value read by the virtual probe
LP (7)	Display the value read by the remote probe (Link ²)
PFi (8)	Display the value read by the filtered virtual probe

Viewer default display (ECPlus)

You need to set parameter **ddE**:

ddd value	Description
SP1 (0)	Display setpoint
Pb1 (1)	Display the value read by Pb1
Pb2 (2)	Display the value read by Pb2
Pb3 (3)	Display the value read by Pb3
Pb4 (4)	Display the value read by Pb4
Pb5 (5)	Display the value read by Pb5
Pbi (6)	Display the value read by the virtual probe
LP (7)	Display the value read by the remote probe (Link ²)
PFi (8)	Display the value read by the filtered virtual probe
PbC (9)	Display the value read by the KDX terminal probe

Note: If the selected probe is not managed by that specific model, the displayed data should not be considered reliable.

Display during defrost

You need to set parameter **ddL**:

ddL value	Description
0	Display the values read by the regulation probe
1	Display the value read by the regulation probe at the start of defrost
2	Display the label dEF

Set the unit of measure for the temperatures

You need to set parameter **dro**:

dro value	Description
C (0)	Display the temperature in °C
F (1)	Display the temperature in °F

Note: this setting only influences how the temperatures read by the probes are displayed. After changing the unit of measure from °C to °F, the value of parameters **SEt**, **diF**, etc, remains the same and they will take on a different meaning, since they are expressed in a new unit of measure (**SEt** = 10°C becomes **SEt** = 10°F).

Tools

Contents

This section includes the following topics:

MFK (Multi Function Key)	71
UNICARD	71
Copy parameters (UNICARD/MFK)	72
Boot Loader Firmware	73
Terminal shared on Link2	73

MFK (Multi Function Key)

The Multi Function Key (MFK) lets you download/upload a parameter map from/to a device.

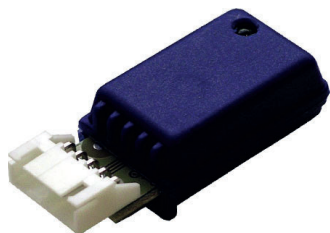

UNICARD

The UNICARD allows uploading/downloading of a parameters map from one device to another. Its flexibility means the various devices can be customized quickly and easily.

The UNICARD:

- can be connected directly to the computer via USB
- Can be powered by means of a power supply unit or a USB battery and directly powers the device during the parameter map downloading/uploading steps.

Power bank

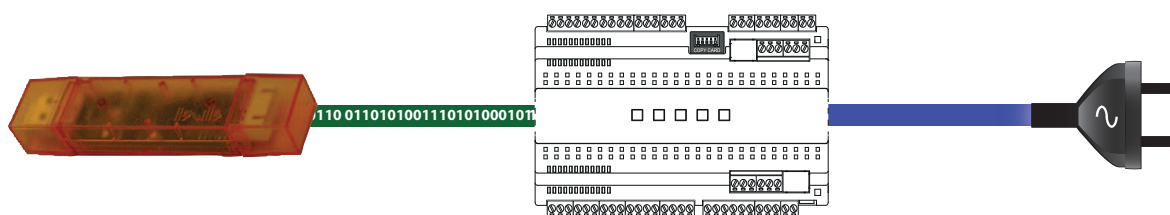

Power supply with USB power supply unit



Power supply with USB battery

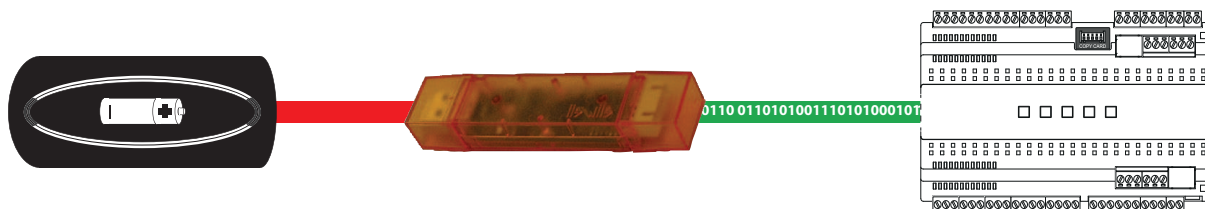

Copy parameters (UNICARD/MFK)







Introduction

The UNICARD/MFK connects to the TTL serial port and allows uploading/downloading of a parameters map.

Note: The UNICARD can be connected directly to a computer by means of a USB port. Format the UNICARD the first time it is used.







Note: Before loading or downloading a map, make sure that communication with the supervisor has been cut off. In other words, disconnect the RS485 from the device or stop Supervision system acquisitions.

Formatting the UNICARD (Fr)







1. Access the Installer parameters, entering the **PA2** password if enabled.
2. Scroll through the folders with  and  until you find the folder **FPr**
3. Press  to confirm.
4. Scroll through the parameters using  and  until you see parameter **Fr** and press : if the operation is a success, the display will show **yES**, otherwise it will show **no**.

Note: This procedure deletes all data on the key. This operation cannot be reversed.

Uploading parameters from the device to the UNICARD/MFK (UL)

1. Access the installer parameters, entering the **PA2** password if enabled.
2. Scroll through the folders with  and  until you find the folder **FPr**
3. Press  to confirm
4. Scroll through the parameters using  and  until you see parameter **UL** and press  to confirm
5. If the operation is completed, the display will show **yES**, otherwise it will show **no**.

Downloading parameters from the UNICARD/MFK to the device (dL)

1. Access the installer parameters, entering the **PA2** password if enabled.
2. Scroll through the folders with  and  until you find the folder **FPr**
3. Press  to confirm
4. Scroll through the parameters using  and  until you see parameter **dL** and press  to confirm
5. If the operation is completed, the display will show **dLy**, otherwise it will show **dLn**.

Note: after downloading the data, the instrument will work with the settings for the loaded map straight away.

Downloading parameters from the UNICARD/MFK to the device (from reset)

Connect the UNICARD/MFK when the device is switched off. When the device is switched on, the data is downloaded automatically from the UNICARD/MFK to the device. After the lamp test, the display shows **dLy** if the operation was successful, otherwise it will show **dLn**.

Note: after downloading the data, the instrument will work with the settings for the loaded map straight away.

Boot Loader Firmware

Description

The device comes with Boot Loader, which makes it possible to update the Firmware directly on site. Updating takes place via UNICARD/MFK.

Operating mode

To carry out the update:

- Connect the UNICARD/MFK with the application loaded onto it
- Restore the device power, if it is off; otherwise, switch it off and on again
- Wait for the UNICARD/MFK LED to flash (operation in progress)
- The operation is complete when the UNICARD/MFK LED is:
 - **ON**: operation completed successfully
 - **OFF**: operation not completed (application incompatible ...)

Terminal shared on Link²

Description

It is possible, from every device in a Link² network and via the local terminal, to navigate within any of the other devices connected to the Link² network.



Operating mode

To activate sharing, press  and  at the same time.

When remote displaying is active, the 2 icons °C and °F flash.

Note: you will be asked to enter the modbus address (**Adr**) for the remote device.

To return to the default menu:

- Press and hold for at least 5 seconds  and 
- Wait for the timeout (60 seconds) after the last time a key was pressed.

During the "remote display function", the local terminal (for the device display being viewed remotely) is locked.

Unlocking takes places 3 seconds after the display release. If during the "remoting" procedure the connection disappears, the display will show "---"

Electronic Expansion Valve (EEV)

Contents

This section includes the following topics:

Introduction	75
List of valves	76
Valve type	77
Refrigerant type	78
Local pressure transducer (4..20 mA)	79
Local ratiometric transducer	79
Pressure/ratiometric transducer shared via Link2	80
Ratiometric transducer shared via hardware	81
Remote backup saturation probe	81
Overheating probe	81
Protection fuse	82
Valve regulation parameters	84
EEV driver description	85
Manual EEV management	86
EEV driver regulation	87

Introduction

The figure below shows a connection example for the device:

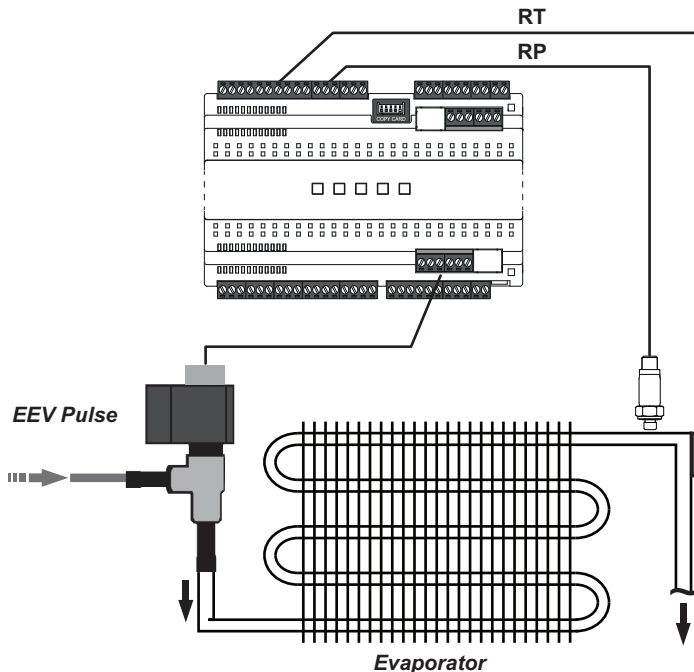

Legend: RT = Refrigerant Temperature; RP = Refrigerant Pressure; EEV Pulse = Pulse Valve; Evaporator = Evaporator.

Use of the Pulse EEV requires configuration of the following resources:

- the overheating probe via parameter **rSS** (NTC/PTC/Pt1000 temperature probe)
- the saturation probe via parameter **rSP** (ratiometric transducer or pressure transducer 4...20 mA).

The **DEFAULT** configuration includes the following settings:

- **Pb5** as overheating probe (NTC probe)
- **Pb6** as saturation probe (pressure transducer 4...20 mA).

⚠ WARNING

UNINTENDED EQUIPMENT OPERATION

- Verify the information concerning valve parameters as declared by the manufacturer before using the valve in a generic valve configuration.
- Connect one valve coil to terminals 61(+) and 62(-) and connect the other coil to terminals 63(+) and 64(-). Crossed connections between the two coils is not permitted.
- After connection, make sure the valve opens and closes correctly after the corresponding command is made.

Failure to follow these instructions can result in death, serious injury, or equipment damage.

Take extra care during the valve wiring stages. Choose the most suitable valve coil carefully in accordance with the voltage used.

⚠ WARNING

UNINTENDED EQUIPMENT OPERATION

Verify the information concerning valve parameters as declared by the manufacturer before using the valve in a generic valve configuration.

Failure to follow these instructions can result in death, serious injury, or equipment damage.

Schneider Electric and Eliwell are not responsible for data provided by the valve manufacturer, including technical changes or updates. Please refer to the valve manual to verify its suitability and correct configuration.

List of valves

The following valves are **COMPATIBLE** with the **RTX 600 IV** device:

Manufacturer	Valve	Notes
Eliwell by Schneider Electric	PXV	Orifices from 0.5 to 2.7 mm

NOTE: The information below is presented in conformity with the technical documentation for the corresponding products listed in the table. Manufacturer specifications are subject to change without notice.

Manufacturer	Valve	Reference document
DANFOSS	AKV10, AKV15, AKV20	DKRCC.PD.VA1.A7.02_AKV_sw.pdf
	AKVA (NH3)	DKRCC.PD.VA1.B5.02_AKVA.pdf
ALCO	EX2	EN_EX2__35016.pdf

Schneider Electric and Eliwell are not responsible for data provided by the valve manufacturer, including technical changes or updates. Please refer to the product manual and the valve manual to verify its suitability and correct configuration.

Valve type

The **RTX 600 IV** device is designed for the management of AC and DC type “Pulse” valves.

The wiring diagram for Pulse electronic expansion valves is as follows:

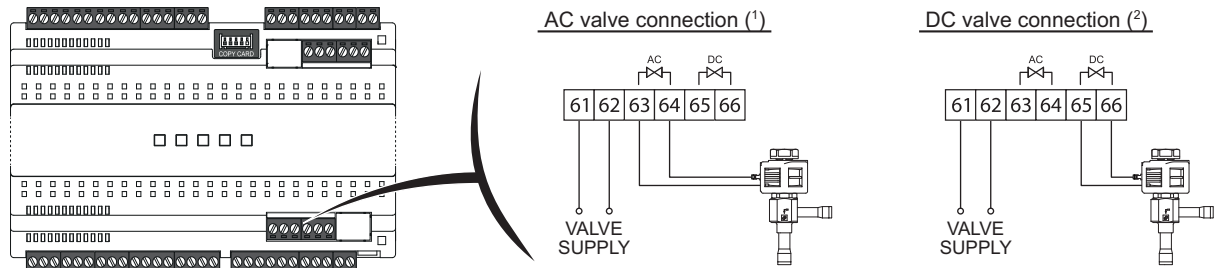

(1) = AC valve connection; (2) = DC valve connection

Before connecting the valve, configure the device carefully by selecting the type of valve used.

Schneider Electric and Eliwell are not responsible for data provided by the valve manufacturer, including technical changes or updates. Please refer to the product manual and the valve manual to verify its suitability and correct configuration.

NOTICE

INOPERABLE DEVICE

- Verify all wiring before engaging the electricity supply.
- Verify the rating data of the valve before connecting it.
- Make sure the valve coil is connected to the correct terminals.
- Make sure terminals 61-62 are connected to an AC power source with voltage of an RMS value suited to the type of valve used.

Failure to follow these instructions can result in equipment damage.

Note: The valve coil should be connected:

- to terminals 63-64 for valves in alternating current (AC)
- to terminals 65-66 for valves in direct current (DC).

Note: Connect terminals 61-62 to an AC power source with voltage of an RMS value:

- equal to the RMS value required by the valve coil if connected to an AC valve.
- equal to the DC value required by the valve coil if connected to a DC valve. For example, to control a valve with DC coil at 240 Vdc, you need to apply a voltage of 240 Vac RMS.

Refrigerant type

This device is designed to operate in non-hazardous locations and where applications which generate - or could potentially generate - hazardous atmospheres have been isolated. Install this device only in areas and with applications known to be free from hazardous atmospheres at all times.

 **DANGER**

RISK OF EXPLOSION

- Install and use this equipment in non-hazardous locations only.
- Do not install or use this equipment in applications which could generate hazardous atmospheres, such as those using flammable refrigerants.

Failure to follow these instructions will result in death or serious injury.

For information regarding the use of control equipment in applications capable of generating hazardous materials, please contact the relevant national regulatory bodies or certifying authorities.

The device can operate with one of the following refrigerants, supplied in the device:

PAR.	Description	UM	Applications
Ert	<p>Selects the type of refrigerant used.</p> <ul style="list-style-type: none"> 404 (0) = R404A r22 (1) = R22 410 (2) = R410A 134 (3) = R134a 744 (4) = R744 (CO2) 507 (5) = R507A 717 (6) = R717 (NH3) 290 (7) = reserved 407 (8) = R407A 448 (9) = R448A 449 (10) = R449A 450 (11) = R450 513 (12) = R513A PAr_1 (13) = customizable 1 PAr_2 (14) = customizable 2 PAr_3 (15) = customizable 3 PAr_4 (16) = customizable 4 PAr_5 (17) = customizable 5 PAr_6 (18) = customizable 6 <p>Note: For customizations regarding the type of refrigerant used, please contact Eliwell.</p>	num	410 (not in applications)

Note: parameter **Ert** is not included in Applications **AP1...AP8** and does not change if the default values are restored or an Application other than the default is loaded.

If you need to use a refrigerant that is not on the list, you can load the “refrigerant descriptor” (containing the key values corresponding to the refrigerant used) via UNICARD/Multi Function Key and then set parameter **Ert** = PAr_1, PAr_2, PAr_3, PAr_4, PAr_5 or PAr_6.

Note: To get the “refrigerant descriptor”, please contact Eliwell Technical Support.

Local pressure transducer (4..20 mA)

The wiring diagram for the pressure transducer is as follows:

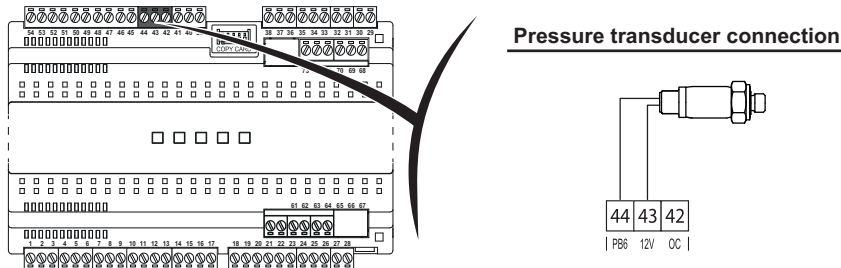

Legend: Pressure transducer connection = Pressure transducer connection

Set parameter **rSP**=Pb6 to use the 4..20 mA input (Pb6) as a saturation probe.

Set the lower limit (to 4 mA) and the upper limit (to 20 mA) using parameters **H03** and **H04**.

Note Parameters **H03** and **H04** refer to relative pressure (atmospheric pressure = 0.0 bar).

Local ratiometric transducer

The wiring diagram for the ratiometric transducer is as follows:

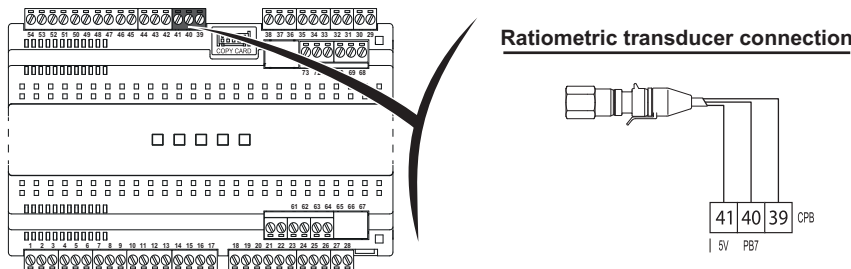

Legend: Ratiometric transducer connection = Ratiometric transducer connection

Set parameter **rSP**=Pb7 to use the ratiometric input (Pb7) as a saturation probe. Use parameter **trA** to set one of the ratiometric transducers listed:

PAR.	Description	UM	Applications
trA	<p>Selects the model of ratiometric transducer used.</p> <ul style="list-style-type: none"> USE (0) = Generic Probe Set by customer rA1 (1) = EWPA 010 R 0/5 V 0/10 BAR FEMALE rA2 (2) = EWPA 030 R 0/5 V 0/30 BAR FEMALE rA3 (3) = EWPA 050 R 0/5 V 0/50 BAR FEMALE rA4 (4) = AKS 32R -1 ...6 BAR rA5 (5) = AKS 32R -1 ...12 BAR rA6 (6) = AKS 32R -1 ... 20 BAR rA7 (7) = AKS 32R -1 ... 34 BAR rA8 (8) = Reserved. <p>Note: The upper and lower limits for probes rA1... rA8 are preset (and cannot be changed), while if you select USE you will need to set them via parameters H05 and H06.</p>	num	USE (not in applications)

If the ratiometric transducer is not present in the presets, you can configure it manually by setting parameter **trA**=USE.

In this case, set the following parameters:

- H05:** lower limit for the corresponding probe to 0.5 V (10%)
- H06:** upper limit for the corresponding probe to 4.5 V (90%)

Pressure/ratiometric transducer shared via Link2

If the devices are connected in a Link2 network, one or two saturation sensors can be connected and their value shared.

EXAMPLE 1:

Sharing a saturation probe.

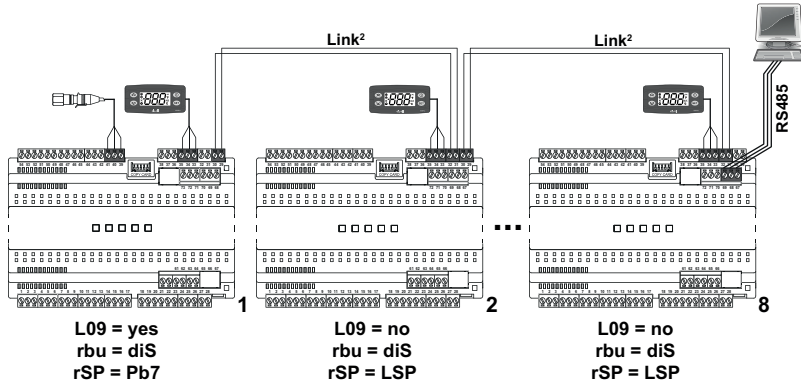

Update the saturation probe sent by the supervision system with a period that is 3 minutes shorter, otherwise the probe will be considered as being in error.

If the probe is in error, all devices will regulate according to the configuration created using the probe error parameters.

In the event of no-link, all Link2 devices, which are not capable of receiving the value from the device with the sensor fitted, will behave as though the saturation probe is in error.

EXAMPLE 2:

Sharing two saturation probes connected to two separate boards in the Link2 network (to increase the reliability of the system, in the event of a fault).

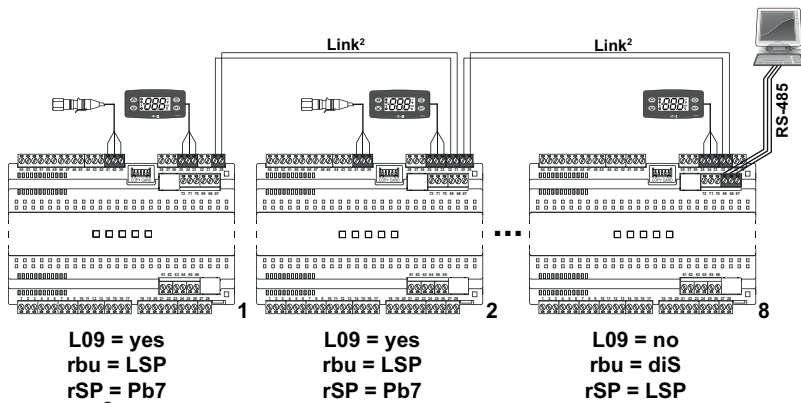

The Link2 will automatically share one of the two values available (the first value received). The other device, equipped with a pressure transducer, will not use the value shared, instead using the local value, unless it is in error, in which case the shared value will be used.

If the pressure transducer used for sharing enters error mode, the Link2 network will automatically take steps to share the pressure value of the other transducer (provided that this is not in error).

If both saturation probes are in error, or a no-link condition arises, the boards will take steps to regulate in accordance with the saturation probe in error scenario.

Ratiometric transducer shared via hardware

The wiring diagram for the shared ratiometric transducer is as follows:

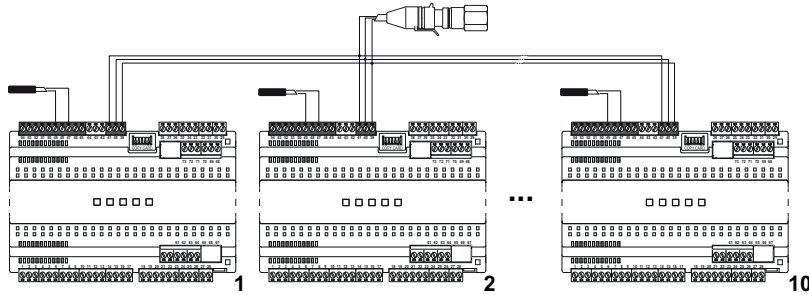

The ratiometric input is configured in exactly the same way as for the non-shared “Local ratiometric transducer”. To use a shared ratiometric transducer (**Pb7**), set parameter **rSP=rP**.

Remote backup saturation probe

A backup saturation value can be sent to devices in the Link² network via serial commands. If the device has no valid saturation value (local or shared), it can use the backup saturation value originating from a remote source.

If the remote device does not update the value within 3 minutes, the device will consider the backup probe as not available, so will regulate according to the conditions detected by the saturation probe in error.

Overheating probe

Position the overheating probe (you can select its type (NTC, PTC or rPt1000) using parameter **H00**) as shown in the figure.

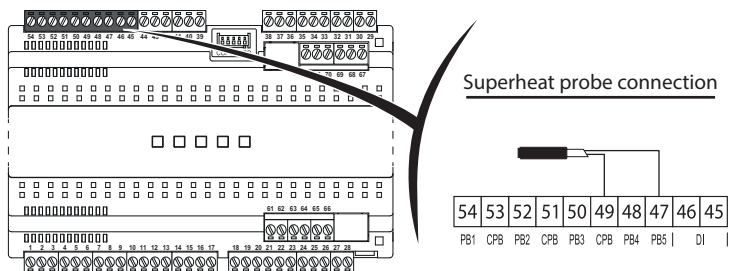

Legend: Superheat probe connection = Overheating probe connection

Protection fuse

The **RTX 600 /V** device has an internal fuse protecting it from the valve coils
If the fuse trips, it must be replaced.

DANGER

RISK OF ELECTRIC SHOCK, EXPLOSION, FIRE OR ARC FLASH

- Disconnect all power from all equipment including connected devices prior to removing any covers or doors, or installing or removing any accessories, hardware, cables or wires except under the specific conditions specified in this user manual.
- Always use a properly rated voltage sensing device to confirm the power is off where and when indicated.
- Before restoring the power supply, replace and secure all covers, hardware components and cables.
- For all the devices requiring it, make sure there is an effective ground connection.
- Use only the specified voltage when operating this device and any associated products.
- Do not connect the device directly to the line voltage, unless expressly indicated.

Failure to follow these instructions will result in death or serious injury.

DANGER

RISK OF OVERHEATING AND FIRE

Replace the fuse with a new one of the same type and specification.
For specification details, please see the "Environmental and electrical characteristics" section of this document.

Failure to follow these instructions will result in death or serious injury.

When handling the equipment, take care to avoid damage caused by electrostatic discharge. In particular, the unshielded connectors are extremely vulnerable to electrostatic discharge.

WARNING

UNINTENDED EQUIPMENT OPERATION DUE TO ELECTROSTATIC DISCHARGE

- Keep the equipment in the protective packaging until ready for installation.
- The device must only be installed in type-approved cupboards and/or in points that prevent unauthorized access and provide protection from electrostatic discharge.
- When handling sensitive equipment, use a grounded device protecting against electrostatic discharge.
- Before handling the equipment, always discharge the static electricity from the body by touching an earthed surface or type-approved antistatic mat.

Failure to follow these instructions can result in death, serious injury, or equipment damage.

Replacing the fuse

The fuse replacement procedure is as follows:

1. Disconnect all disconnectable terminals on the Top Board (electronic expansion valve and RS485 network).
2. Remove the cap using a screwdriver on the tabs on both sides.
3. Remove the fuse you want to replace from the Top Board
4. Insert the new fuse (**Note:** verify the correct size in the section "Environmental and electrical characteristics")
5. Re-fit the cap, pressing evenly until you hear the side tabs click into place
6. Reconnect all the disconnectable terminals on the Top Board.

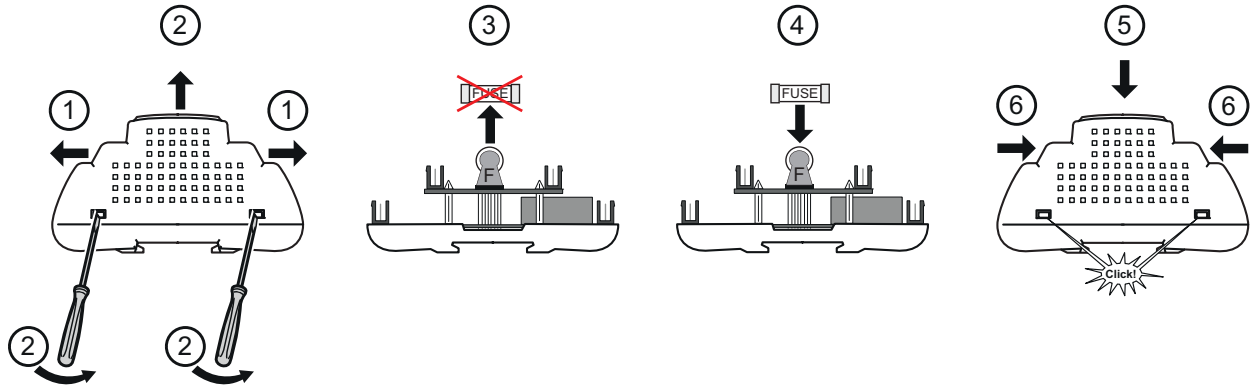

Valve regulation parameters

RTX 600 /V is a device for Pulse electronic expansion valves that regulates the minimum overheating value at the evaporator output.

The control algorithm can adapt itself to the counter conditions to achieve the performance levels desired by the user. The user will only be asked to set the setpoint temperature (**OLt**) and the algorithm will adapt itself to reach the desired performance levels. The algorithm is optimized for operation with low overheating setpoints.

The internal driver has user configurations that can be used to set:

- **U02**: the maximum valve opening percentage
- **U05**: the operating time at maximum opening before the alarm is triggered
- **U06**: the minimum useful valve opening percentage for modulation
- **U07**: the maximum useful valve opening percentage for modulation.

If regulation requires a value under **U06**, valve opening will be 0%, while if regulation requires an opening value over **U07**, the valve will be open at the value **U02**.

Notes:

- If the regulator controls an output greater than or equal to **U07**, the actual output will be equal to **U02**
- If the regulator controls an output less than or equal to **U06**, the actual output will be equal to 0%
- If the regulator controls an output greater than or equal to **U07** for a time period greater than **U05**, a maximum opening alarm will be generated to indicate a hazardous condition for the system.

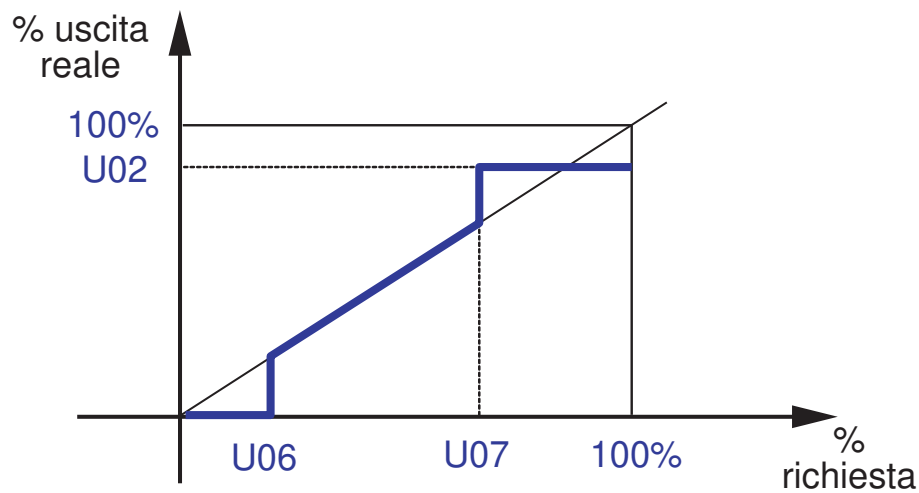

EEV driver description

The driver has the following functions:

- **MOP**: for controlling the “maximum operating pressure” (can be activated with **HOE**).
- **Dead Rack**: for selective load disabling (can be activated with **U25**).
- **Continuous Modulation**: continuous control of EEV opening

Notes:

- Activation/deactivation of the EEV driver will run parallel to the compressor status
- the saturation probe should be connected directly to the device.
- Boards connected to Link2 can manage the shared saturation value as:
 - Regulation probe (local probe absent)
 - Backup probe (for use when the local probe is in error).
- Updating of the remote value for the saturation probe should be transmitted within 180 seconds (3 minutes), otherwise the probe will be considered to be in error.
- In continuous modulation, the compressor will always be on call, except when alarms are present.
- During a defrost period, the valve remains shut.

Force EEV closure from Digital Input or remote command, regardless of the regulation in progress and without any signaling. This function is used for regular control unit pump down times, when analyzing refrigerant leaks and retrieving oil.

The driver has user configurations that can be used to set:

- **U02**: maximum EEV opening
- **U06**: minimum valve opening value during modulation as a percentage
- **U07**: maximum valve opening value during modulation as a percentage.

If regulation requires a value under **U06**, valve opening will be at 0%, while if regulation requires an opening value over **U07**, the valve will be open at the value **U02**.

If the valve opening percentage is above **U07** for a period greater than **U05**, the EEt alarm will be activated.

If the saturation temperature is greater than parameter **Hot** for a time greater than parameter **tAP**, the EEP alarm will be activated.

If there is an error in the saturation probe and the LAN or remote backup probes are not available, the EES alarm will be activated.

MOP (Maximum Operating Pressure) function

The "MOP" function for controlling the “maximum operating pressure” can be activated by configuring parameter **HOE** and controls valve closure proportionally as the saturation temperature approaches the value of parameter **HOt** (maximum evaporator temperature), with a proportional band equal to parameter **HPb**.

MOP regulation can be disabled:

- using parameter **HOE**
- for a time period **HdP** on device startup or on returning from a defrost condition.

Dead Rack (Maximum Operating Pressure) function

The “Dead Rack” function (group of non-operational compressors) can be activated by configuring parameter **U25** and involves deactivating the loads selected using parameter **U25** when the saturation temperature is greater than the value of parameter **U26**.

The function has a hysteresis of 1°C or 1°F. This means is a high saturation temperature occurs (and therefore high pressure), the system considers the group of compressors as having malfunctioned and deactivates the loads selected by the user to avoid rapid defrosting of the products (the loads are: lights, frame heater, defrost, evaporator fan).

The deactivation of loads can also be controlled remotely.

Continuous Modulation function

The "Continuous Modulation" function can be activated via parameter **rE= 5** or **rE= 6** and is activated when the counter reaches the temperature **SP1**, or in the case of energy saving, the temperature of the sum (**SP1+OS1**).

When the function is activated the driver regulates valve opening so that the temperature of the counter remains constant and that overheating is greater than the value set with parameter **OLT**.

This function reduces temperature fluctuations and makes it possible to work at a higher saturation temperature, increasing the efficiency of the system.

One or both probes in error

If one or both probes are in error:

- If the pressure transducer is in error and **U22=En** (enabled), the saturation temperature backup value **U23** will be used. The MOP function will be disabled.
- if the pressure transducer is in error and **U22=diS** (disabled), the valve will be set to a fixed opening percentage **U8**. The MOP function will be disabled.
- if the temperature probe is in error, the driver will maintain a fixed opening percentage **U8** for the valve. The MOP function will be active, modulating the valve opening percentage in the range 0...**U8**.
- if the both probes are in error, the driver will maintain a fixed opening percentage **U8** for the valve.

Manual EEV management

The device can control the valve in manual mode.

There are two ways of doing so:

- management via the terminal.
- management via serial port with remote control.

Management via terminal

Activation takes place by configuring the parameter **A_F=En**, while the valve opening percentage is set with parameter **dUt**.

If there is no power supply or the system is switched off, it will restart with the function deactivated.

An hour after activation, the function will be deactivated automatically.

Management via serial port with remote control

Activation takes place by writing the logic resource at the address **H282F**.

The following settings can be applied:

- **0** = disable manual mode
- **1** = activate manual mode, with a 1 h timer from its activation
- **2** = activate manual mode, with reloading of the timer after 1 h and setting of the resource to 1. The desired percentage should be written at the logic resource for address **H2830**.

The manual function controls valve opening even when alarms are present, except if alarms relating to the EEV driver (**E13** and **E14**) are present.

EEV driver regulation

Fixed opening with temperature control off

If temperature control is off, a fixed opening percentage can be set for the EEV using parameter **U27**.

This function makes it possible to drain the evaporator.

Fixed opening at temperature control startup

When temperature control begins, a fixed EEV opening percentage can be forced via parameter **U64**, in addition to its implementation period via parameter **U65**.

This function makes it possible to deactivate the overheating regulation algorithm for a specific period, allowing the system to “stabilize” and preventing low pressure alarms.

Once the delay **U65** has elapsed, the EEV will be controlled by the overheating algorithm.

Note: If **U65=0**, this function is disabled.

Continuous Modulation

Continuous modulation with a single thermostat

Continuous modulation with a single thermostat can be activated by configuring parameter **rE=5**.

The algorithm modulates the EEV to maintain the regulation temperature within the band $(SP1 - dF1) \dots (SP1 + dF1)$.

If overheating falls below the setpoint **OLt**, the regulator will reduce valve opening so as to bring the value back above **OLt** (this will be to the detriment of temperature regulation).

Continuous modulation with a dual thermostat in series

Continuous modulation with a dual thermostat in series can be activated by configuring parameter **rE=6**.

The regulation temperature corresponds to the temperature nearest its setpoint.

The algorithm modulates the EEV to maintain the difference between the temperature and the relevant setpoint within the band $(- dF1) \dots (+dF1)$.

If overheating falls below the setpoint **OLt**, the regulator will reduce valve opening so as to bring the value back above **OLt** (this will be to the detriment of temperature regulation).

Continuous Modulation and Oil management

Oil management is activated when using continuous modulation, as the oil may be “deposited” inside the evaporator (this is due to the limited flow of refrigerant).

To overcome this problem, the PUMP IN/OUT can be activated; every **U55** seconds it closes the valve for a time period **U53** and then reopens it at 100% for a time period **U54**.

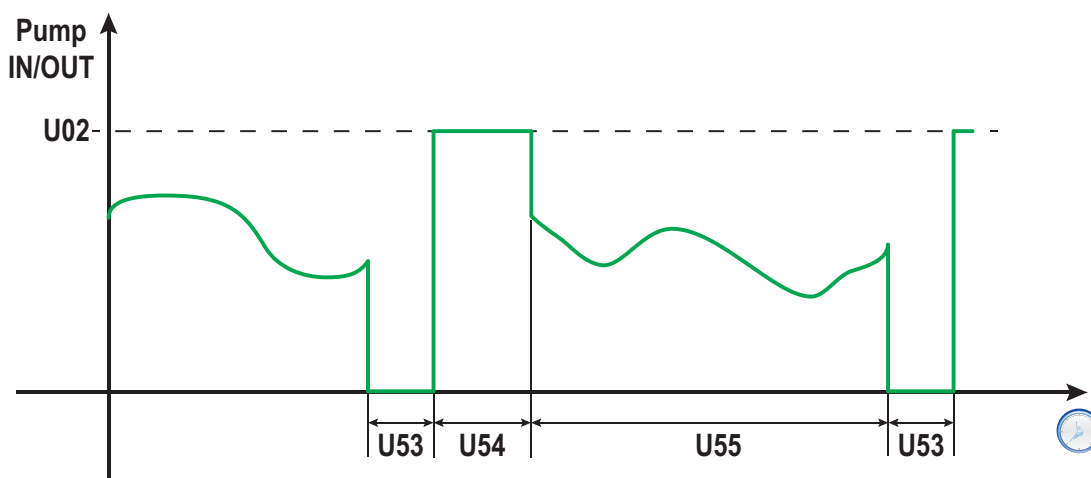

Overheating filter

This filter is used in systems with rapid changes in suction pressure or thermal load (e.g. in cold rooms), which cause rapid changes in overheating, requiring a “trigger” liquid injection.

This overheating filter (alpha filter) is active within the range $(OLt - U61) \dots (OLt + U61)$ and uses an **alpha** coefficient = $[0.9 + (U51/10000)]$:

$$TshE = Current * (1 - alpha) + TshE * alpha$$

where:

- **TshE**: is the overheating temperature at the filter outlet.
- **Current**: is the current estimation of the overheating value

Saturation temperature filter

This filter is used in systems with suction pressure that changes quickly but with a limited range, and that can generate “instabilities” in liquid injections.

This filter is activated when the current saturation temperature and the previous value is:

- $|Tsa - TsaFiltered| \geq U63 \rightarrow TsaFiltered = Tsa$
- $|Tsa - TsaFiltered| < U63 \rightarrow TsaFiltered = TsaFiltered * (1 - U62/1000) + Tst * (U62/1000)$

where:

- **Tsa**: is the saturation temperature.
- **TsaFiltered**: is the filtered saturation temperature.

Recalculating the reference overheating

Parameter **U14** can be used to define the minimum value of the band used to calculate the valve implementation percentage (the lower the band value, the higher the reactivity of the system).

Custom refrigerants

Up to 6 custom refrigerants can be stored in the memory. They are selected by configuring parameter Ert (values from 13 to 18 corresponding to the values from **par_1** to **par_6**).

Local Network

Contents

This section includes the following topics:

Introduction	90
Supervision gateway	90
Temperature probe sharing	91
Synchronized Defrost	92
Simultaneous Defrost	93
Sequential Defrost	95
Display shared on Link2	97
Setpoint value sharing	97
Sharing commands	97

Introduction

Up to 8 devices can be connected in a Link² network and just one device can be connected to the Modbus supervision network.

Link² configuration takes place using the same addresses as the supervision system. No limitation is applied to the addresses (they may also be non-contiguous) and it is not necessary to configure a device as the Master.

The supervision system can be connected to just one device belonging to a Link² network, which will function as a gateway for the other devices connected to the local network.

Every device will make the information regarding the number of devices connected available.

An example of Link² + Supervision network connection is as follows:

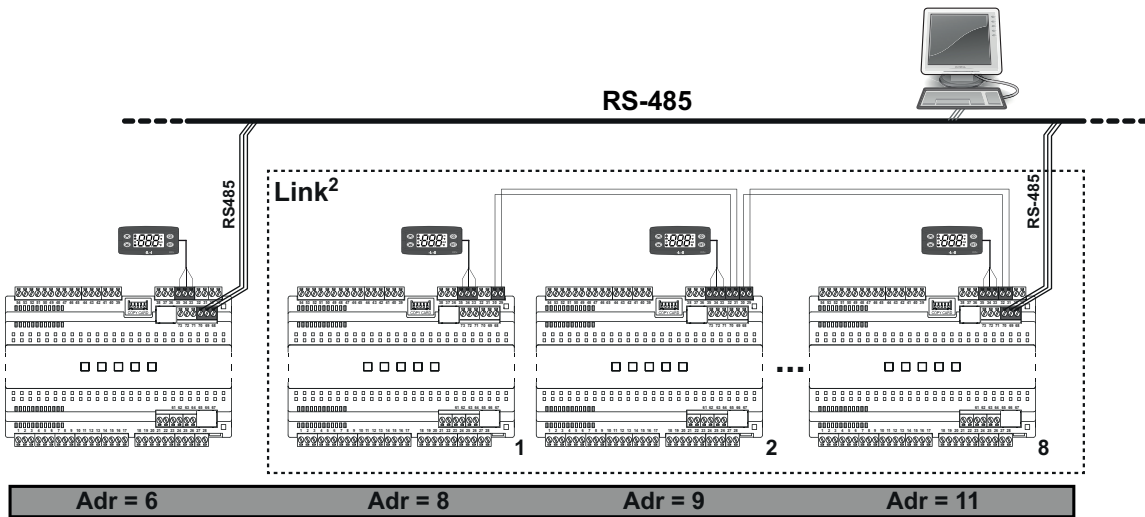

Supervision gateway

The RS-485 supervision line can be connected to any of the boards in the Link² network. The latter will automatically take steps to “direct” communications to other boards.

The RS485 network does not require any specific configuration for addresses as it uses those already set for supervision of the network (parameter **Adr**).

Temperature probe sharing

The Link² network can be used to share one of the 5 temperature probes (Pb1...Pb5) or the virtual probe.

EXAMPLE 1:

Sharing the regulation probe (in the example, the probe is connected to device 2).

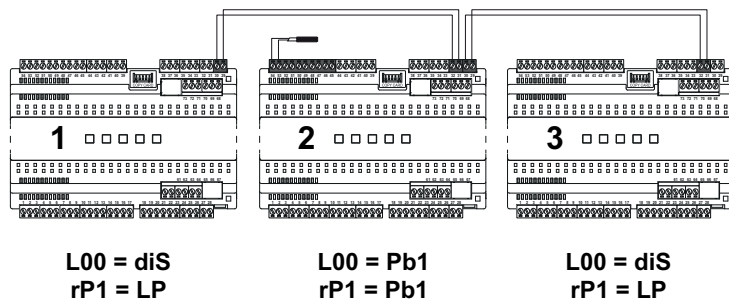

EXAMPLE 2:

Sharing the probe in a remote counter, where every section has its own regulation probe and one of the regulation probes is not working (in the example, the probe for device 2 which is marked with a red X).

In this case the section in question can be made to regulate using the value read from one of the adjacent sections. This process can be carried out remotely:

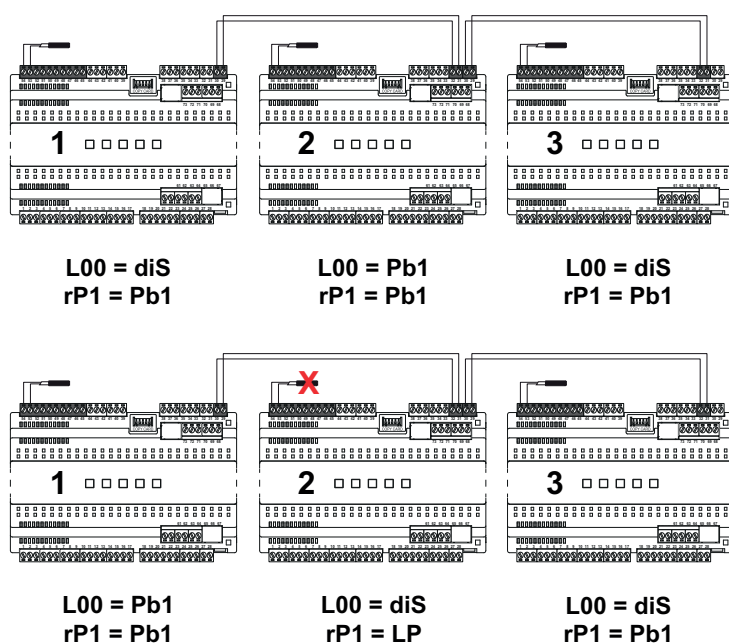

Note: The sharing of the temperature probe does not apply only to temperature regulation, but also for other regulators (evaporator fans, heating elements, etc.).

Synchronized Defrost

Definition

Defrosts can be synchronized in a local Link² network with respect to the actual defrost phase. The dripping phases are not taken into account.

Within it there is a Master device (the one connected to the Modbus supervision network) and Slave devices (the other instruments in the local Link² network).

The Master (if **L03**≠0) is limited to sending enabling commands for starting defrosts or temperature control without interfering with the protections or delays configured on each individual device (e.g. dripping, etc.).

Once a Slave device has finished its synchronized defrost, it waits to receive enabling for temperature control from the Master and in the meantime its defrost icon flashes.

If the Slave devices in the local Link² network are programmed to accept commands from the Master, any associated defrosts and/or functions will not be activated, with the exception of the following defrosts:

- manual
- from Televis
- following a deep cooling cycle.

Associated defrosts and/or functions will only be carried out by the Slave devices if a “no link” alarm is present (E7).

Operating conditions:

- in a local network, defrost commands and activation of the functions associated with the events are controlled exclusively by the Master (if the slaves are programmed to do so)
- if there is no communication, every element in the network works individually for the cooling chain.

A safety mechanism can be set on Slave devices that locally forces a defrost if they do not receive a defrost command from the Master device within the timeout period **dit** (with **dit**≠0). The timeout is reset at every defrost.

Note: If **dit**=0 this safety mechanism is disabled.

There are two types of defrost, linked to the value of **L03**:

- **L03** = 1: simultaneous defrost
- **L03** = 2: sequential defrost

Parameter **L04** can be used to indicate whether, once defrost is complete, the device waits for all the others to finish before being able to reactivate regulation.

This means there is still a timeout that forces reactivation of regulation once a time period set with **L10** elapses (e.g. the Link² network line is interrupted while a defrost is in progress).

Simultaneous Defrost

In a Link² network it is possible to activate defrosts simultaneously, coordinated by the nominated Master device, by setting **L03=1**.

The Master device will send a defrost request to all devices defined as Slave simultaneously.

At the end of the defrost, temperature control will be activated based on parameter **L04**:

- if **L04=ind** it will resume after every defrost and corresponding period **dt** has ended
- if **L04=dEP** it will resume after all defrosts and corresponding periods **dt** have ended.

Operating diagrams

Independent simultaneous defrost (L04 = ind)

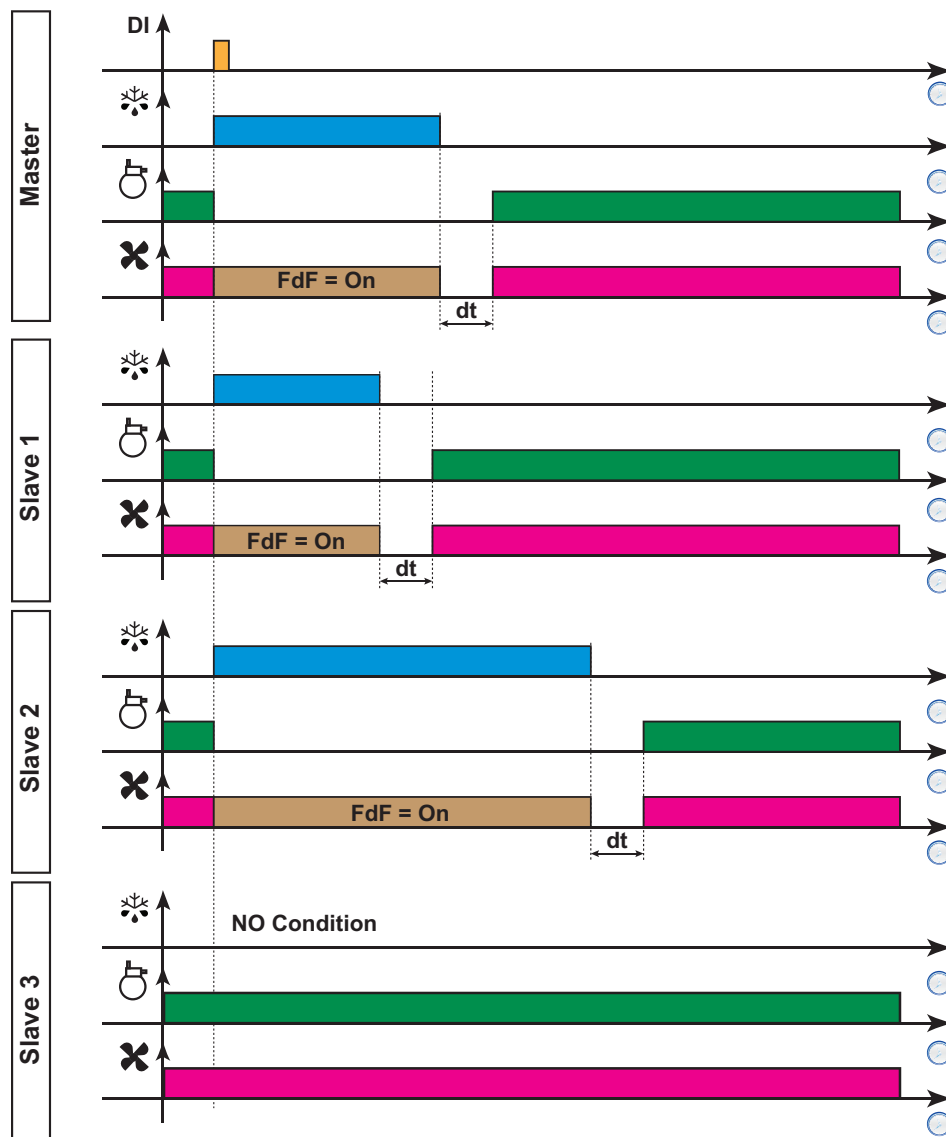

Dependent simultaneous defrost (L04 = dEP)

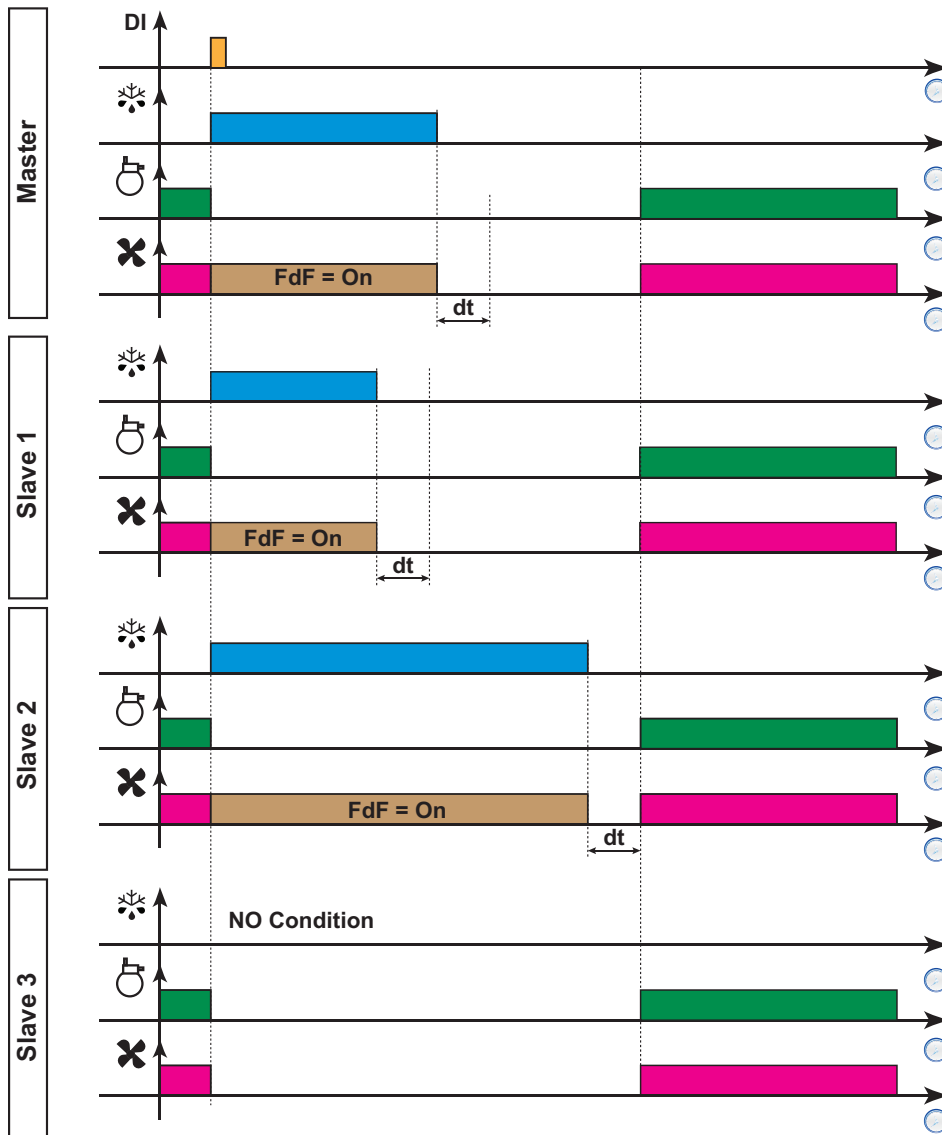

Legend:

- DI = Digital Input
- ❄️ = Defrost
- 🌀 = Compressor
- ✖️ = Fans
- **NO Condition** = The conditions for defrosting are not met

Sequential Defrost

In a Link² network it is possible to activate defrosts sequentially, coordinated by the nominated Master device, by setting **L03=2**.

The Master device will send a sequential defrost request to all devices defined as Slave.

The defrosting order depends on the sequence in which the devices were recognized at the last power-on. The sequence may vary.

At the end of the defrost, temperature control will be activated based on parameter **L04**:

- if **L04=ind** it will resume after every defrost and corresponding period **dt** has ended
- if **L04=dEP** it will resume after all defrosts and corresponding periods **dt** have ended.

Operating diagrams

Independent sequential defrost (L04 = ind)

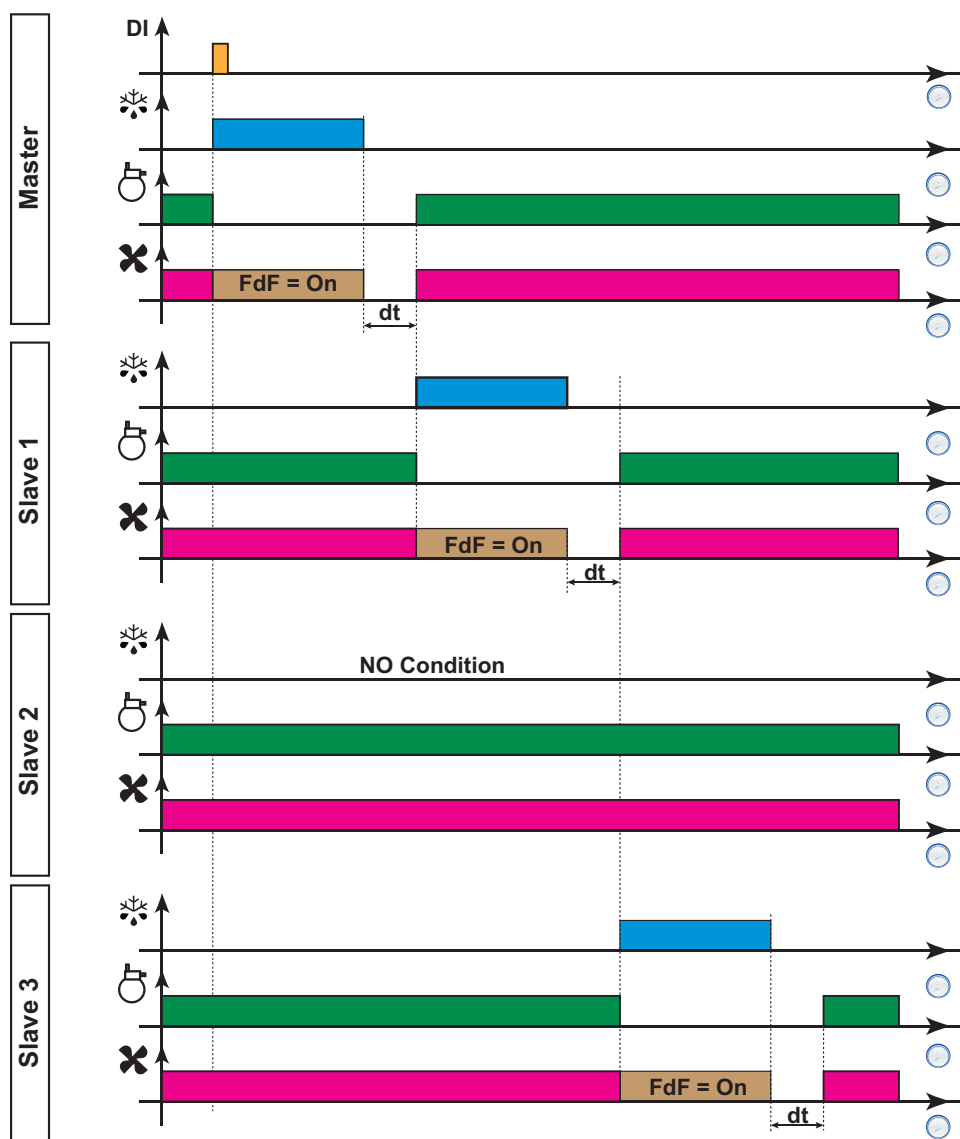

Dependent sequential defrost (L04 = dEP)

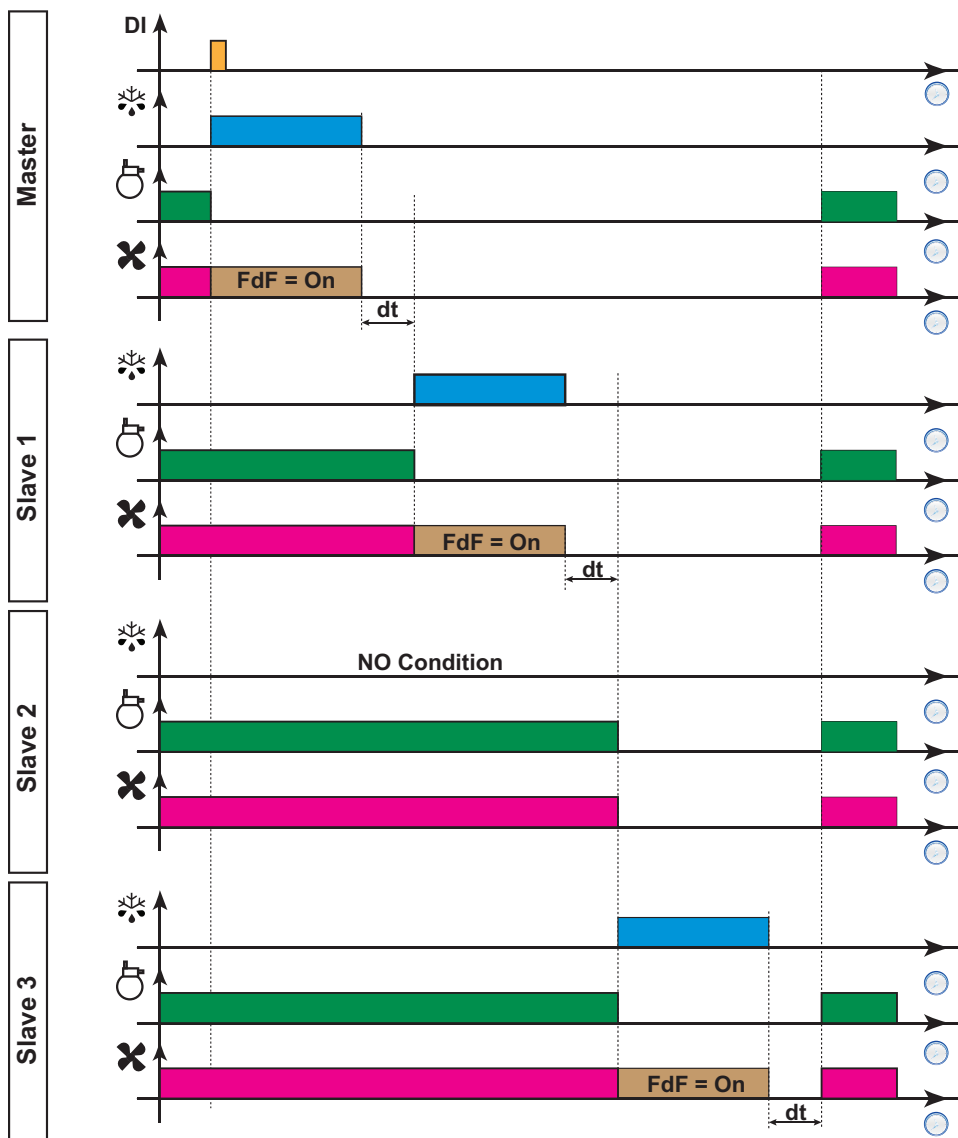

Legend:

- DI = Digital Input
- ❄️ = Defrost
- 🌀 = Compressor
- ✖️ = Fans
- **NO Condition** = The conditions for defrosting are not met

Display shared on Link²

To ensure that all terminals for the remote counter display the same value, the display of a certain device can be shared via the Link² network.

EXAMPLE:

In the example, all terminals will display the value of device 2.

Devices no.1 and no.3 will display the value of the probe fitted on device 2, which was selected via parameter **ddd**.

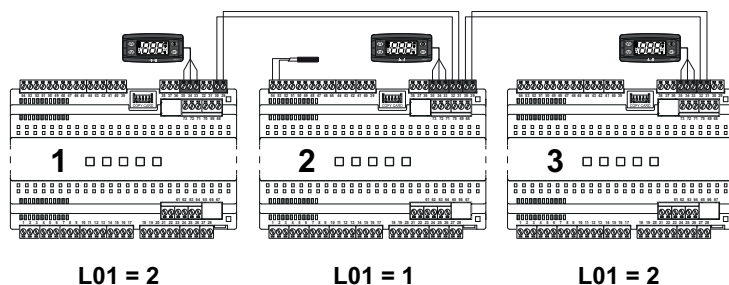

Notes:

- If device 2 (which is sharing its value with the local network) has an active alarm indication on the display (e.g. probe alarm), this is not shared with devices 1 and 3
- If device 2 shares the value of a probe that is not working, the other devices will display the value selected by local parameter **ddd**
- If device 1 and/or device 3 have additional alarm signals (e.g. local probe alarms), these are only displayed locally
- If device 1 and/or device 3 do not receive the probe value from device 2 due to a lack of signal in the Link² network, they will display the value selected by local parameter **ddd**.

Setpoint value sharing

The Link² network can be used to share regulation setpoint **SP1** between all boards. If the setpoint is changed on any of the boards in the Link² network, all the other boards in the local Link² network will be updated automatically (if **L02=yES**).

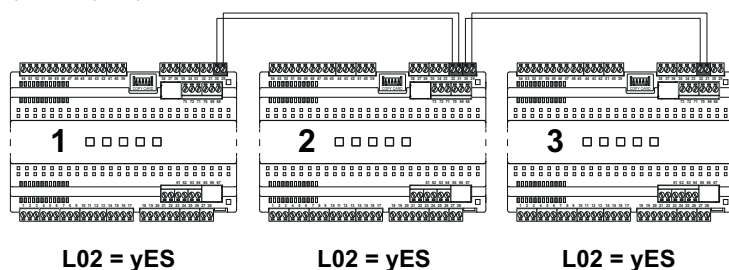

Note: When parameter **L02=yES**, if the value of a setpoint is changed on any of the devices, that value will be propagated to all other devices in the network. If one of the devices is disconnected from the network or communication is lost, after the setpoint value is changed it will use the new value set.

Sharing commands

The Link² local network can be used to share the following commands:

- Stand-By
- Lights
- AUX
- Energy Saving

(See parameters **L00 ... L12** in the folder Lin)

Defrost

Contents

This section includes the following topics:

Defrost/Dripping	99
Display and alarm operation	100
Automatic Defrost	101
Manual defrost	102
RTC Defrost	104
Electric heater defrost	106
Inversion defrost	108
Hot gas defrost for plug-in systems	110
Hot gas defrost for systems with remote group	111
Modulating electric heater defrost: Smart Defrost	112
Dual evaporator defrost	113

Defrost/Dripping

Activation

Defrosting removes ice from the surface of the evaporator.

If **dt** ≠ 0, once defrost is complete, a dripping cycle takes place to prevent the water left on the evaporator from freezing again.

Defrost is activated:

- automatically (depending on the mode selected with **dCt**) from:
 - compressor run time (Digifrost)
 - device run time
 - compressor stop
 - RTC (if the RTC is not working device run time is used instead)
 - by temperature: when the evaporator temperature is lower than the defrost end setpoint **dSS** for a time period **dit** (not applicable for dual evaporator systems).
- press and hold a key (configured with **H3x** = 1)
- digital input (**DI**) (only if **H1x** = ±1)
- using a Supervisor, via Modbus command (serial)
- via Link2 network

To select the defrost type, set parameter **dtY** (defrost type).

Defrost takes place due to the evaporator heating up, in one of the following ways:

dtY value	Defrost mode
0	Electric heater defrost
1	Inversion defrost
2	Hot gas defrost for plug-in systems
3	Hot gas defrost for systems with remote group
4	Modulated electric heater defrost (Smart Defrost)

Operating conditions

Defrost does NOT start automatically and the display will flash three times if:

- a manual defrost is already underway.
- the defrost activation timer has elapsed and the temperature of the first evaporator is higher than the defrost end setpoint **ds1** (**ds2** for defrost on the second evaporator), in which case a new timer count will begin.

Defrost can take place in the ways listed below:

Method	Conditions
Device switch-on	if parameter dPO =1 (defrost at start-up)
Time intervals	every time the defrost time interval dit elapses (if dit >0).
Manually (via key)	press and hold a key for at least 5 seconds if enabled (H3x =1). If OdO ≠0, the cycle does not begin, the request is rejected and the display will flash three times to indicate that defrosting is not possible.
External request via DI	By activating a suitably configured DI (H1x =1). Activation via DI observes the automatic cycle protections. If OdO ≠0, the cycle does not begin, the request is rejected and the display will flash three times to indicate that defrosting is not possible.

Setting the dripping interval

To activate dripping at the end of the defrost cycle, set parameter **dt** ≠ 0. During dripping, the fans are switched off even if **Fdt** < **dt**.

Parameters

Parameter	Description
ds1	Temperature value set for the end of defrost on evaporator 1.
ds2	Temperature value set for the end of defrost on evaporator 2.
Fdt	Fan activation delay after a defrost.
dt	Dripping duration.

Display and alarm operation

Alarm operation during defrost

You can activate an alarm for defrost ending due to timeout, by setting parameter **dAt** = y (see alarm **Ad2** in the section "Alarms and indications" a pagina 147).

In the event of a regulation probe error, defrosts will still take place and, during defrost, the temperature alarm associated with the probe error will be excluded.

Displayed values

By setting parameter **ddL**, you can choose the values displayed during the defrost phase until the end of dripping time.

The value shown on the display may be configured in one of the following ways:

- **ddL** = 0: display the temperature read by the regulation probe
- **ddL** = 1: display the temperature read by the regulation probe at the start of defrost
- **ddL** = 2: display (steadily) the label **dEF** (defrost)

Unlocking the display

The display can be unlocked in one of the following ways:

- on reaching the setpoint and after dripping
- on reaching the display unlock timeout value, defined by parameter **Ldd**

Parameters

Parameter	Description
dAt	Defrost ended due to timeout alarm indication.
ddL	Display mode during defrosting.
Ldd	Display unlock timeout value - label dEF .

Automatic Defrost

Introduction

The defrost cycle begins at set intervals.

Note: To stop automatic defrosts from taking place, set **dit**=0.

Operating conditions

If **dit**>0, defrosts will take place at fixed intervals as per **dit** and interval time counting will be calculated as follows:

Par.	Value	UM	Description	Notes
dCt	0	num	Defrost disabled	-
	1	num	Compressor running time --- DIGIFROST® method	The count is active only when the compressor is on. When the defrost interval elapses a new count begins and a defrost cycle starts if the conditions for doing so are met. Note: the compressor running time is counted independently of the evaporator temperature. If the evaporator probe is missing or not working, the count will still be active in the compressor running period.
	2	num	Device running time	The defrost interval count is always active when the device is on and starts at every power-on. When the defrost interval (dit) elapses, a defrost cycle starts if the conditions for doing so are met, along with the count for a new defrost interval.
	3	num	Compressor stop	Each time the compressor stops, a defrosting cycle is performed in the mode established by parameter dtv .
	4	num	RTC (clock)	The clock can be used to set: <ul style="list-style-type: none"> defrost schedules (6 bands for weekdays and 6 bands for weekends/holidays) regular defrost (every n days) daily events (1 event for weekdays and 1 event for weekends/holidays) Time band and regular defrosts work in a mutually exclusive manner (they do not work at the same time). If defrost using RTC is activated and the clock is not working, defrost will run according to dit (as long as dit ≠0).
5	num	Temperature	The defrost is activated when the evaporator temperature drops below the threshold dSS . If probe dP1 is not working, defrost takes place on the basis of interval dit .	

Defrost does NOT start automatically and the display will flash three times if:

- a manual defrost is already underway.
- the defrost activation timer has elapsed and the temperature of the first evaporator is higher than the defrost end setpoint **dS1** (**dS2** for defrost on the second evaporator), in which case a new timer count will begin.

Manual defrost

Introduction

The Manual Defrost function can be activated in one of the following ways:

- press and hold a key (configured with **H3x** = 1)
- digital input (**DI**) (only if **H11** = ±4)
- using a Supervisor, via Modbus command (serial)

Note: if the **OdO** count is in progress, the defrost cycle does not begin, the request is rejected and the display will flash three times to indicate that defrosting is not possible.

Activation via key

The device enters defrost after you press and hold a key only if **H3x**=1.

The defrost interval count proceeds as described in Automatic defrost, where time period **dE1** is not reset but instead continues.

Defrost does NOT start automatically and the display will flash three times if:

- a manual defrost is already underway.
- the defrost activation timer has elapsed and the temperature of the first evaporator is higher than the defrost end setpoint **dS1** (**dS2** for defrost on the second evaporator), in which case a new timer count will begin.

Defrost is always enabled apart from when **dit**=0.

Activation via Digital Input

The device enters defrost when a Digital Input is activated only if **H11**= ±4.

Note: defrost activation takes place upon closure ($H11 > 0$) or opening ($H11 < 0$) of the digital input DI (if activated). You can only activate a defrost, not end an active one. Any defrost or dripping cycle in progress and the defrost or dripping time cannot be suspended.

Note: with **dS1** the defrost end time due to reaching the Setpoint temperature is indicated and with **dE1** the defrost ends due to timeout is indicated.

Regulation examples

Example 1 (**H11** = 4):

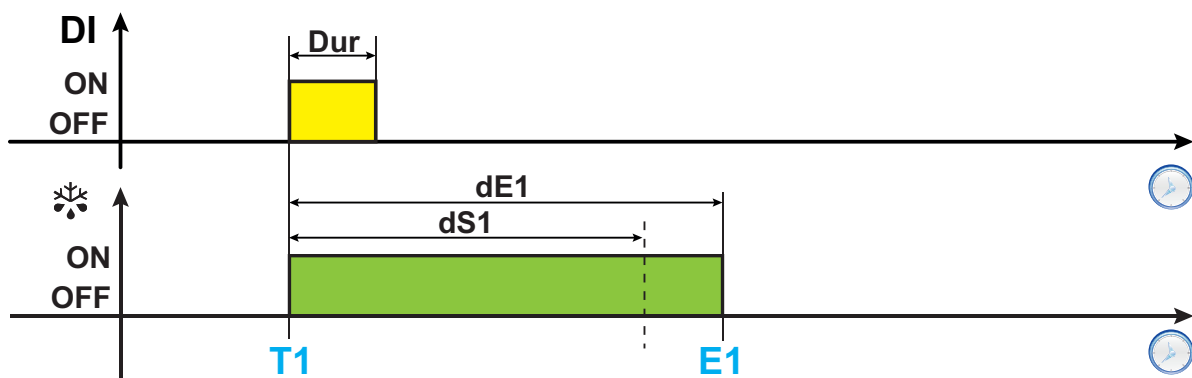

Example 2 (H11 = 4):

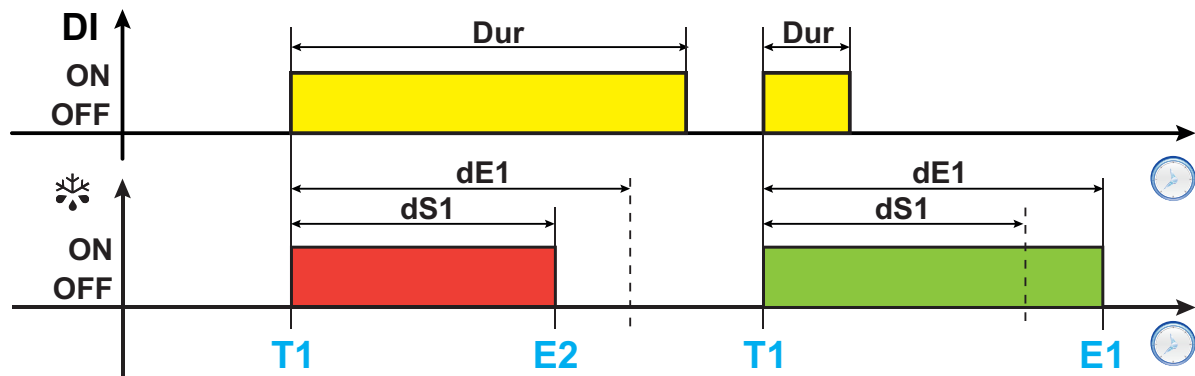

Example 3 (H11 = 4):

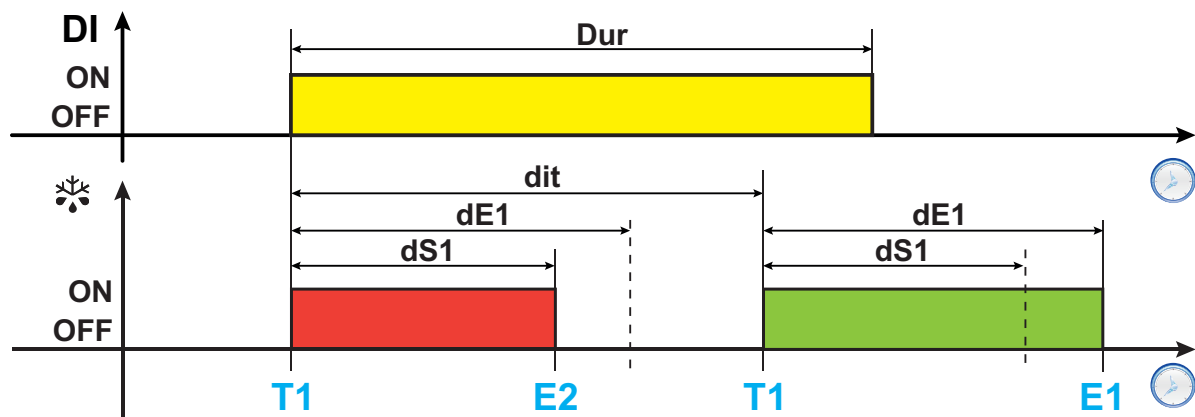

Legend: Dur = DI Duration; DI = Digital Input; ❄ = Defrost; T1 = Defrost request; T2 = Regular defrost request with fixed expiration; E1 = Defrost end due to timeout; E2 = Defrost end due to temperature.

Parameters

Parameter	Description
dit	Time interval between one defrost and the next.
dE1	Evaporator 1 defrost timeout.
dE2	Evaporator 2 defrost timeout.
OdO	Output activation delay time from switching on the controller or after a power failure.
dS1	Evaporator 1 defrost end temperature.
dS2	Evaporator 2 defrost end temperature.
H1x	Digital input x/polarity configuration.
H3x	x key configuration.

RTC Defrost

Weekdays/Weekends and Holidays

The controller can manage up to two weekend/holiday days. They can be selected via parameters **Fd1** and **Fd2**.

For example:

- **EXAMPLE 1:** 1 weekend/holiday day (Monday).
Set: **Fd1**=1 (Monday), **Fd2**=7 (disabled)
- **EXAMPLE 2:** 2 weekend/holiday days (Wednesday and Sunday).
Set: **Fd1**=3 (Wednesday) and **Fd2**=0 (Sunday) or **Fd1**=0 (Sunday) and **Fd2**=3 (Wednesday)

Time band defrost

The controller can manage up to 6 daily defrosts, with two setpoints, one for weekdays and one for weekends/holidays.

In addition to defrost start schedules, you can decide whether to use a defrost end setpoint and timeout that are the same for all defrosts, or to set different values for each event.

- If **Edt**=0, each time band will use the same set defrost end **dS1** (**dS2**) and the same timeout **dE1** (**dE2**).
- If **Edt**=1, a specific setpoint **dS1** and timeout **dE1** can be set for each event.

This means that longer and/or more intensive defrosts can be set during store closure periods (when the thermal load on the counters is lower). This mode is recommended for systems with single evaporator defrosting.

For dual evaporator defrosting, all defrosts use the same **dS2** and **dE2** and these values cannot be customized.

The following structure is used when setting the time:

Min	Current schedule: minutes.	0...59	min	H68=y
Hur	Current schedule: hours.	0...23	hours	H68=y
dAY	Current schedule: day. 0: Sunday; 1: Monday; 2: Tuesday; 3: Wednesday; 4: Thursday; 5: Friday; 6: Saturday.	0...6	num	H68=y

Regular defrost

Some counters only require a defrost cycle every two days or longer.

This is possible using the set of parameters relating to regular defrost, where the activation schedule and repeat interval (in days) is set.

Multiple defrosts

Parameters **Fdn** and **Ffn** can be used to carry out several defrosts at regular intervals over the course of the day, only setting the time band for the first defrost.

This mode is active when:

- For weekday defrosts **Fdn**≠0 and **d1H**≠24
- For weekend/holiday defrosts **FFn**≠0 and **F1H**≠24

For example, if **Fdn**=8 and the first time band is set to 2:00, the following will occur:

- First defrost at 2:00
- Second defrost at 5:00 (2:00 + 24h/Fdn)
- Third defrost at 8:00 (2:00 + 2*(24h/Fdn)
- ...
- Eighth defrost at 23:00 [2:00 + 7*(24h/Fdn)]

Note: if one or more defrosts are calculated for the day after the first defrost they will be ignored.

Events

The controller can manage two specific events, one applicable to weekdays and one to weekends/holidays. These events have a start time and a duration.

A typical example would be store closure periods when, through events, it is possible to automatically switch off the light, close the shutters, increase the setpoint and implement other energy saving functions.

This result can be achieved by indicating the time at which the store will close, while the duration of the event is simply the duration of the period of closure.

Depending on the value of parameter **ESt**, each event can carry out one of the following functions:

- **ESt** = 0: Function disabled
- **ESt** = 1: Energy Saving activation (*)
- **ESt** = 2: Energy Saving activation (*) and Light off
- **ESt** = 3: Energy Saving activation (*), Light off and AUX output activation
- **ESt** = 4: Device Stand-by activation
- **ESt** = 5: Energy Saving activation (*) + Buzzer silencing
- **ESt** = 6: Energy Saving activation (*) and Light off + Buzzer silencing
- **ESt** = 7: Energy Saving activation (*), Light off and AUX output activation + Buzzer silencing
- **ESt** = 8: Device Stand-by activation + Buzzer silencing

(*) for functions associated with Energy Saving, refer to the specific section.

Parameters

Parameter	Description
dE1	Defrost 1 timeout.
dE2	Defrost 2 timeout.
dS1	Defrost 1 end temperature.
dS2	Defrost 2 end temperature.
Fd1	1st weekend/holiday day.
Fd2	2nd weekend/holiday day.
Edt	Sets whether you want to enter a duration and defrost end temperature for each event
Fdn	Number of multiple defrosts during one weekday.
FFn	Number of multiple defrosts during one weekend/holiday day.
d1H	1st weekday defrost start hour.
F1H	1st weekend/holiday defrost start hour.
ESt	Type of event activated via RTC.

Electric heater defrost

Electric heater defrost is used in “**LOW TEMPERATURE**” applications and is selected by setting **dt** = 0.

When electric heater defrost is activated:

- The compressor stops
- the relay to which the electric heaters are connected, configured as defrost regulator output, is activated

At the end of defrost, the heaters switch off and the compressor remains inactive for the dripping time set in parameter **dt** (if a value other than zero). At the end of the dripping time, temperature control begins again as normal.

End of defrost

Defrost ends in the following conditions:

Condition	Evaporator probe (dP1)	H42 value
End of timeout period set using parameter dE1 .	Not managed	0
Defrost end setpoint set using parameter dS1 reached or due to timeout if the setpoint is not reached within the time period dE1 .	Managed	1

Notes:

- To end defrost manually, switch the controller off and on again or use the ON/OFF function (Stand-by)
- If **dS1** intervenes before **dEt**, dripping (managed by parameters **dt** and **Fdt**) is activated in correspondence with **dS1**
- If **Fdt < dt** **Fdt = dt** is set
- During the defrost the fans are off if **dFd = y**, otherwise they follow the other settings for the fan regulator

Regulation diagram

End of electric heater defrost due to timeout

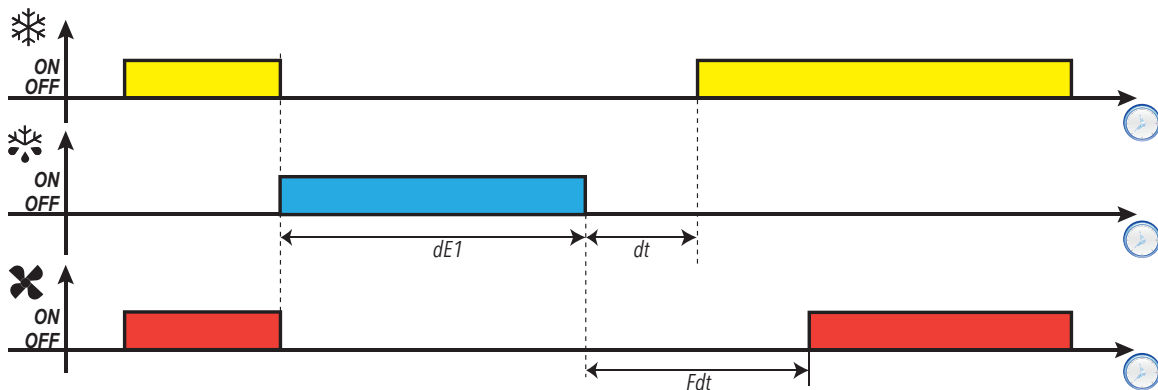

End of electric heater defrost due to temperature

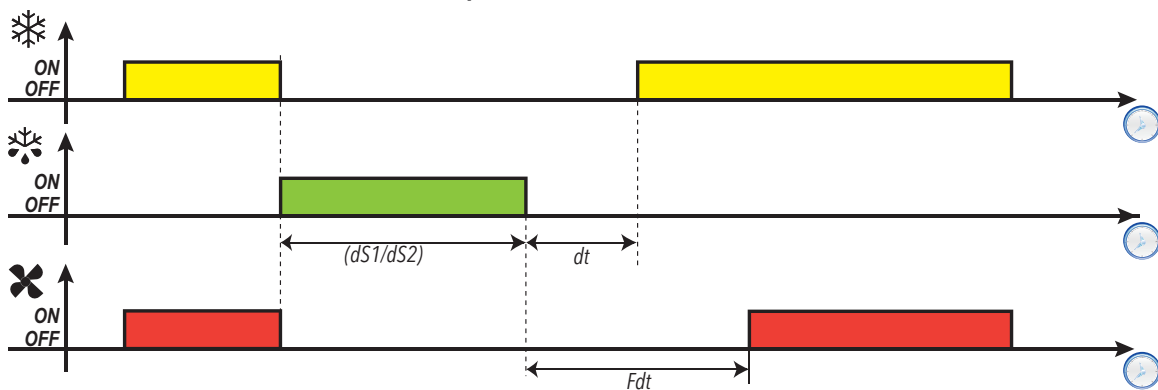

Parameters

Parameter	Description
dOn	Compressor relay activation delay time from call.
dOF	Delay time after compressor relay switch-off and the next switch-on.
dbi	Delay time between two compressor switch-ons.
dtY	Type of defrost.
dEt	Defrost timeout. Determines the maximum duration of the defrost.
dS1	Evaporator 1 defrost end temperature.
Fdt	Fan activation delay after a defrost.
dt	Dripping duration.

Inversion defrost

Cycle inversion defrost is used in “**LOW TEMPERATURE**” applications and is selected by setting **dt** = 1.

When cycle inversion defrost is activated:

- The compressor is always on
- the relay to which the solenoid valve is connected, configured as defrost regulator output, is activated

At the end of defrost the valve relay will be de-energized and the dripping phase set by parameter **dt** will be interrupted (if a value other than zero). The compressor relay reverts to being under the control of the compressor regulator.

End of defrost

Defrost ends in the following conditions:

Condition	Evaporator probe (dP1)	H42 value
End of timeout period set using parameter dEt	Not managed	0
Defrost end setpoint set using parameter dS1 reached or due to timeout if the setpoint is not reached within the time period dEt .	Managed	1

Notes:

- To end defrost manually, switch the controller off and on again or use the ON/OFF function (Stand-by).
- The compressor safety timings (managed by parameters **dOn**, **dOF** and **dbi**) take priority over defrost
- If **dS1** intervenes before **dEt**, dripping (managed by parameters **dt** and **Fdt**) is activated in correspondence with **dS1**
- If **Fdt < dt** **Fdt = dt** is set
- During the defrost the fans are off if **dFd = y**, otherwise they follow the other settings for the fan regulator

Regulation diagrams

End of inversion defrost due to timeout, with **tcd > 0**

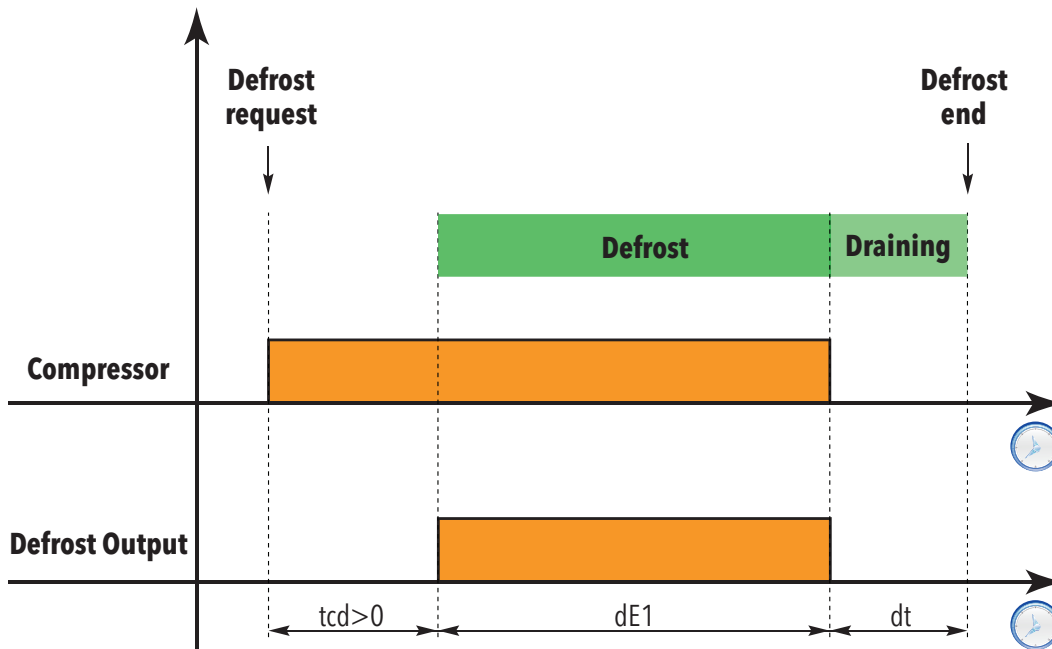

End of inversion defrost due to temperature, with $tcd > 0$

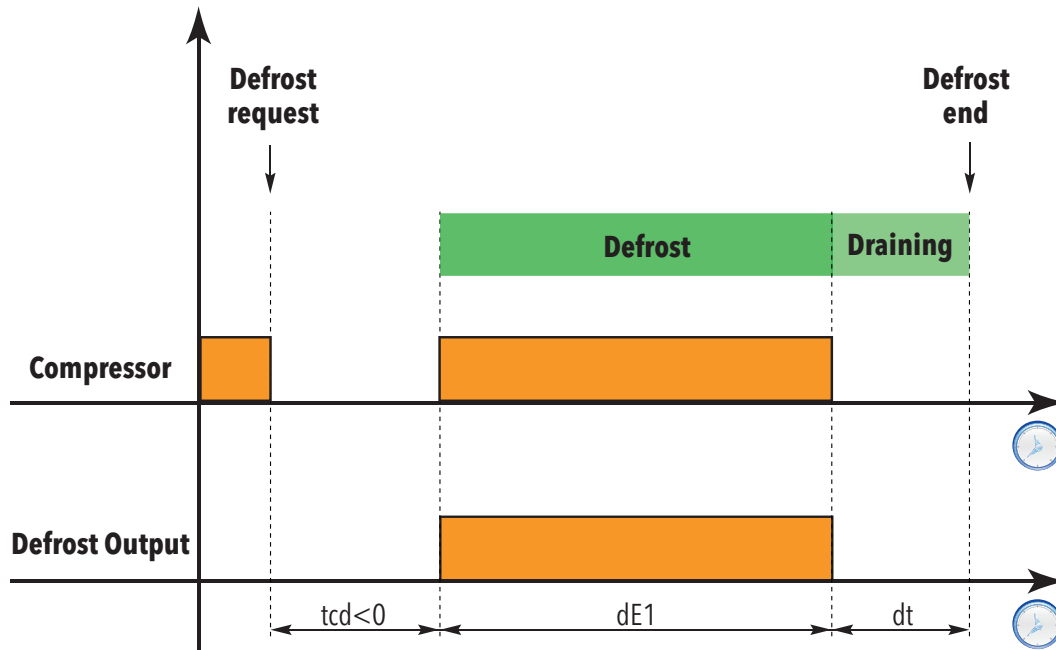

Legend:

- **Defrost Request** = Defrost start request
- **Defrost** = Defrost Period
- **Draining** = Dripping Period
- **Defrost end** = End of defrost
- **Compressor** = Compressor
- **Defrost Output** = Defrost output

Hot gas defrost for plug-in systems

Hot gas defrost for **PLUG-IN** systems differs from cycle inversion defrosting as the refrigerant must be sufficiently heated before defrost begins; it is selected by setting **dt** = 2.

When hot gas defrost for **PLUG-IN** systems is activated:

- the EEV output is off (if present and enabled)
- The fans are off

The defrost cycle consists of the following phases (or a sub-group of them):

- **Deep cooling:** gas heating and coils storage in the counter, for a time period **tdC**>0
- **Pump down:** removal of cold gas from inside the evaporator, for a time period **tPd**>0
- **Defrost:** injection of hot gas, for a time period between **ndE** and **dE1**
- **Dripping:** completion phase for the removal of water from the evaporator (for a time period **dt**)

Regulation diagram

Scenario with **tcd > 0**, **dt** = 2 and **PdC = 0**:

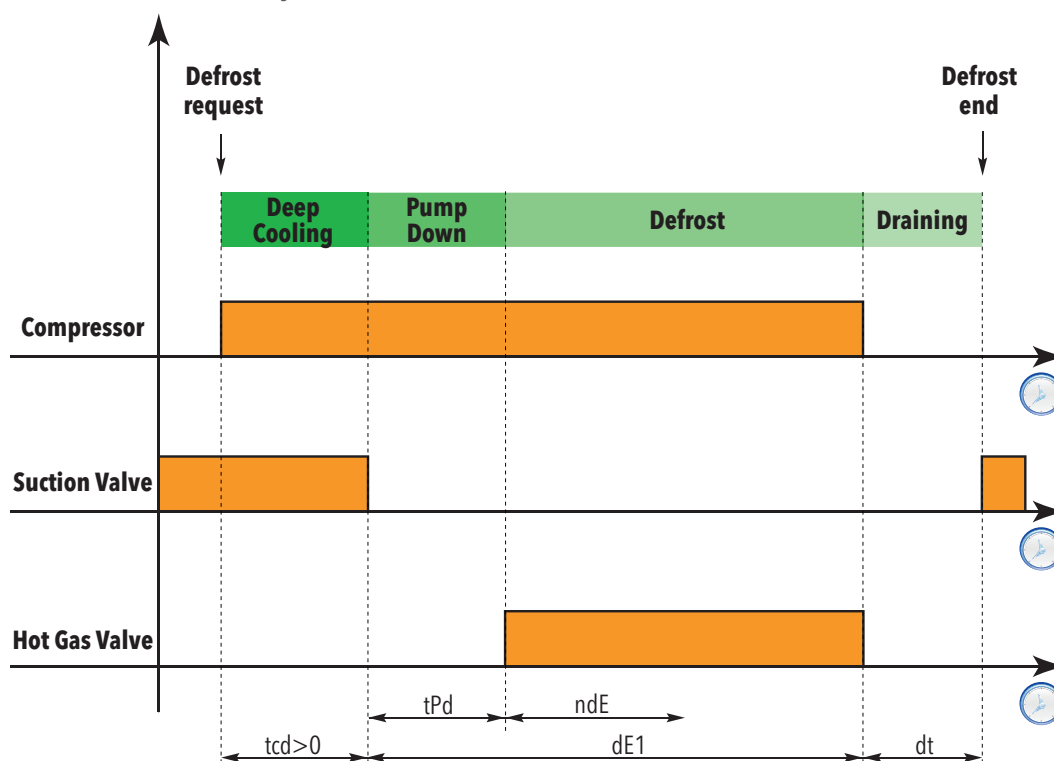

Legend:

- **Defrost Request** = Defrost start request
- **Deep Cooling** = Deep Cooling period
- **Pump Down** = Pump Down period
- **Defrost** = Defrost Period
- **Draining** = Dripping Period
- **Defrost end** = End of defrost
- **Compressor** = Compressor (**H2x** = 1 with **x** = 1...5)
- **Suction Valve** = Suction valve output (**H2x** = 13 with **x** = 1...5)
- **Hot Gas Valve** = Hot gas valve output (**H2x** = 2 with **x** = 1...5)

Hot gas defrost for systems with remote group

Hot gas defrost for systems with a **REMOTE** group differs from cycle inversion defrosting as the refrigerant must be sufficiently heated before defrost begins; it is selected by setting **dt** = 3.

When hot gas defrost for systems with a **REMOTE** group is activated:

- the EEV output is off (if present and enabled)
- The fans are off

The defrost cycle consists of the following phases (or a sub-group of them):

- **Pump down**: removal of cold gas from inside the evaporator, for a time period **tdC**<0
- **Defrost**: injection of hot gas, for a time period between **ndE** and **dE1**
- **Dripping**: completion phase for the removal of water from the evaporator (for a time period **dt**)
- **Pump down**: removal of cold gas from inside the evaporator, for a time period **PdC**
- **Regulation**: reactivation of the EEV (if necessary)

Regulation diagram

Scenario with $tcd < 0$, $dt = 3$ and $PdC \neq 0$:

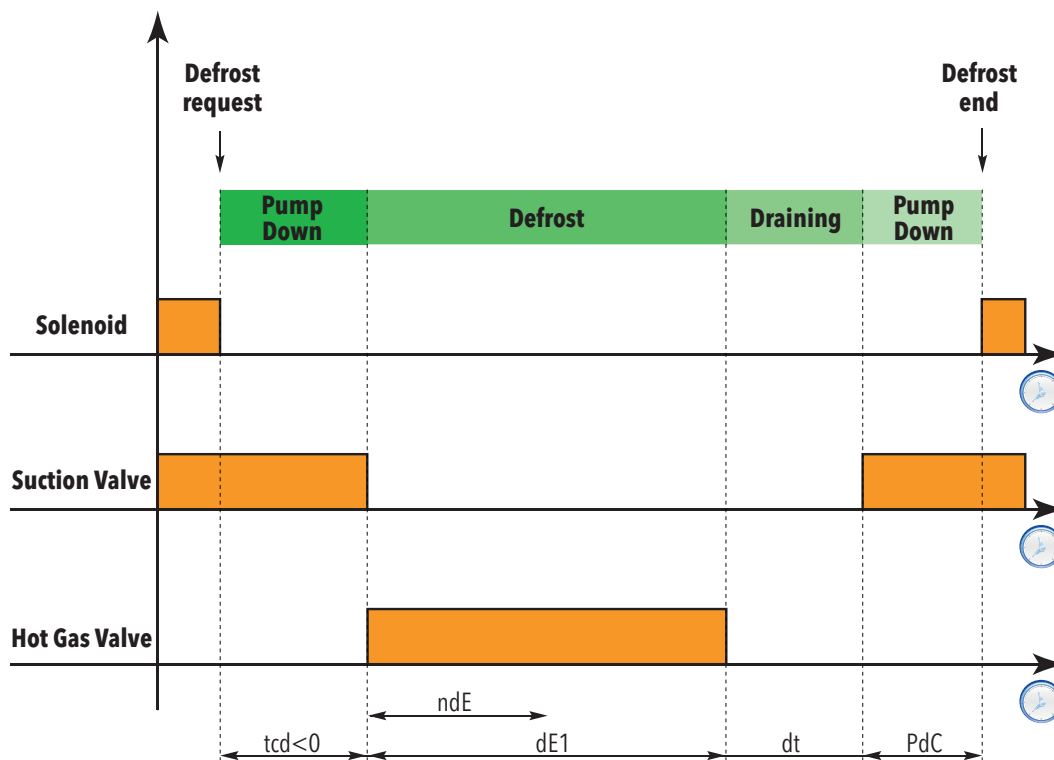

Legend:

- **Defrost Request** = Defrost start request
- **Pump down** = Pump down period
- **Defrost** = Defrost Period
- **Draining** = Dripping Period
- **Pump down** = Pump down period
- **Defrost end** = End of defrost
- **Solenoid** = Solenoid (**H2x** = 1 with **x** = 1...5)
- **Suction Valve** = Suction valve output (**H2x** = 13 with **x** = 1...5)
- **Hot Gas Valve** = Hot gas valve output (**H2x** = 2 with **x** = 1...5)

Modulating electric heater defrost: Smart Defrost

This algorithm can be used to optimize defrost by modulating the heating elements and can be selected by setting **dt_y = 4**.

This algorithm makes it possible to reduce the defrost end setpoint, in relation to standard mode, as the controller, by suitably modulating the heaters, is capable of detecting when all the ice has melted and it is therefore possible to end defrost before the timeout **dE1**.

The configuration of this mode is similar to that used for traditional defrost. Set the same timeout; the defrost end setpoint can be reduced.

Notes:

- This algorithm applies to both single and dual evaporator scenarios
- The function is active if **dt_y=4** and ends due to time (**dE1**) or temperature (**dS1**).

Regulation diagram

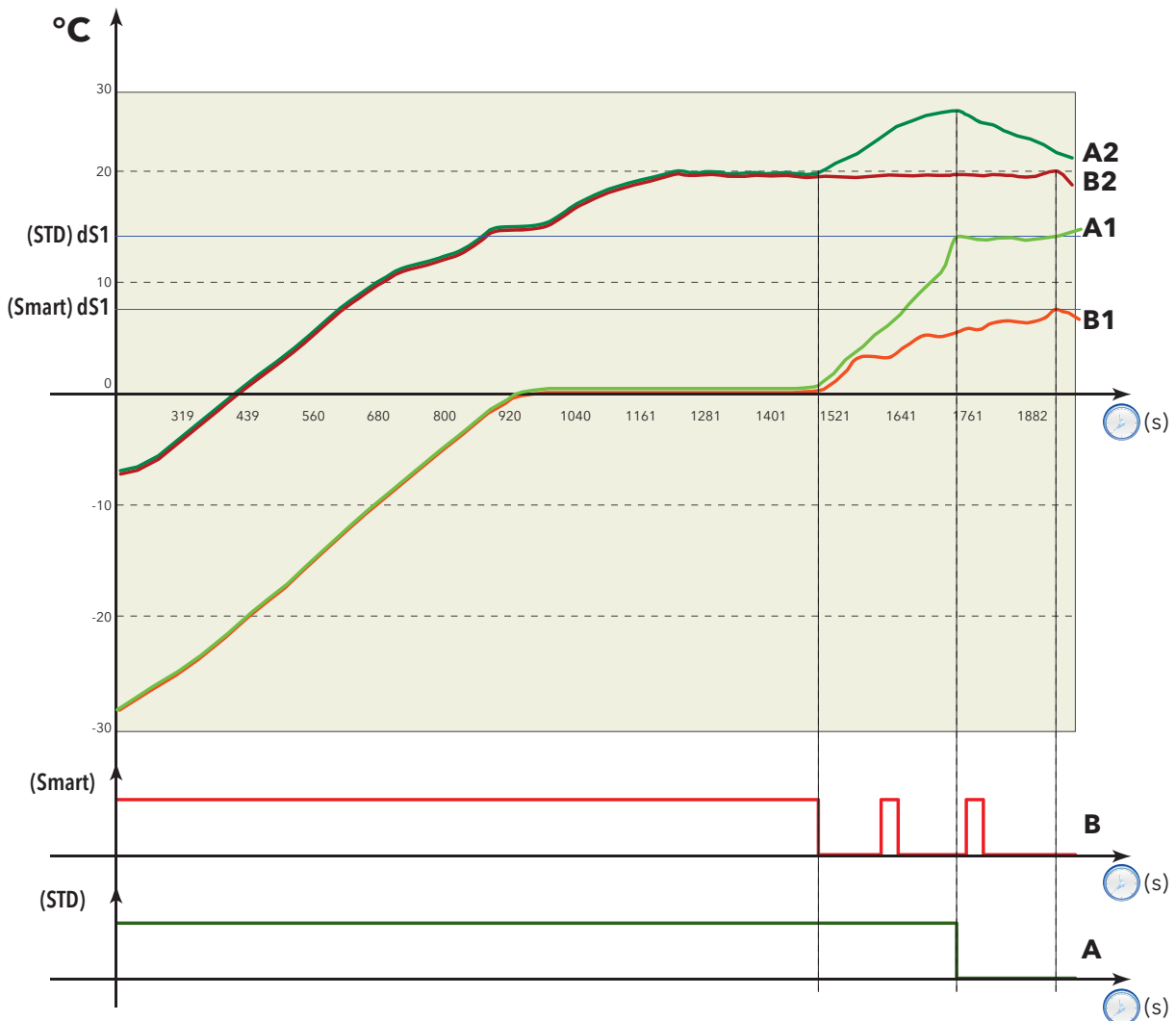

Legend	Curve description
A	“Standard Defrost” Relay Activation
A1	“Standard Defrost” Evaporator Temperature
A2	“Standard Defrost” Counter Temperature
B	“Smart Defrost” Relay Activation
B1	“Smart Defrost” Evaporator Temperature
B2	“Smart Defrost” Counter Temperature

Dual evaporator defrost

Introduction

Dual evaporator defrost is activated with (**dP2** ≠ diS).

In dual evaporator applications, defrost can be optimized by using a probe and an output for each individual evaporator, so as to optimize the heating phase for each individual evaporator, according to actual requirements.

Notes:

- This mode is activated if at least two outputs are configured as defrost (evaporator 1 and evaporator 2)
- Each evaporator has its own set of defrost end and timeout values.

Operation

Conditions for defrost (temperature under the threshold), with two sensors (one per evaporator), can be implemented in one of the following ways

dFt value	Condition
0	Evaporator 1 defrost probe (dP1) under the threshold dS1 .
1	At least one evaporator has the conditions for defrosting, i.e.: <ul style="list-style-type: none"> • Evaporator 1 defrost probe (dP1) under the threshold dS1 or • Evaporator 2 defrost probe (dP2) under the threshold dS2
2	Both evaporators have the conditions for defrosting, i.e.: <ul style="list-style-type: none"> • Evaporator 1 defrost probe (dP1) under the threshold dS1 and • Evaporator 2 defrost probe (dP2) under the threshold dS2

End of defrost

Defrost end for each individual evaporator occurs when:

- time period dE1/dE2 has elapsed (timeout)
- temperature **dS1/dS2** has been reached

Regulators

Contents

This section includes the following topics:

Regulation	115
Evaporator Fans	121
Modulated Fans	127
Condenser Fans	130
Preheating	131
Energy Saving	132
Deep Cooling Cycle (DCC)	133
Auxiliary Output (AUX)	135
Auxiliary Output (Light)	136
Stand-by	137
Soft Start	138
Pump down (Pump out)	139
Compressor oil heater	140
Counter Cleaning Function	141

Regulation

Description

The device allows various regulation methods:

- Single Thermostat
- Dual Thermostat in series
- Dual Thermostat in parallel
- with 2 independent regulators

Note: when using single thermostat mode, you can also have an auxiliary regulator for applications that can be customized by the user (e.g.: light sensor management, etc).

Single Thermostat regulation

The “Single thermostat” regulator ($rE = 0$) is always enabled and can work in heat or cool mode depending on the value of parameter **HC1**.

This regulation makes it possible to manage the regulation differential in absolute or relative mode:

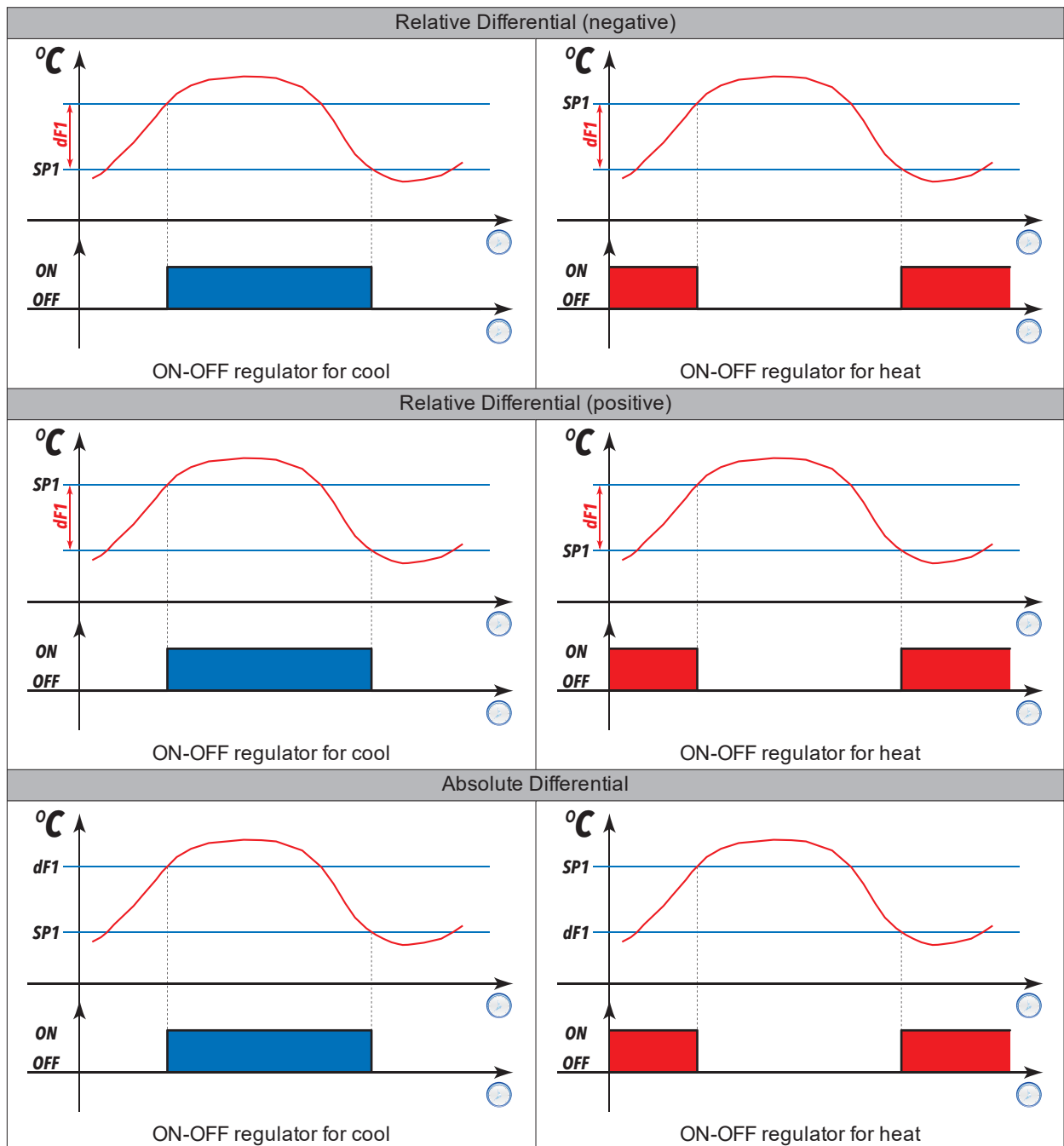

The regulator is managed using the following parameters:

- **rP1**: regulation probe 1 setting
- **SP1**: first regulator setpoint / power off setpoint setting (switch ON)
- **dF1**: first regulator differential / power on setpoint setting (switch OFF)
- **Stt**: differential mode setting (Absolute or Relative)
- **HC1**: first regulator heat/cool mode setting

Dual Thermostat in series regulation

This regulator only activates the production of cold/heat if both thermostats are active, and deactivates it when at least one of the two thermostats is satisfied (cabinet with 2 probes, one in delivery and one in pick up).

In the event of a probe error on one or both thermostats, regulation will use the probe error parameters.

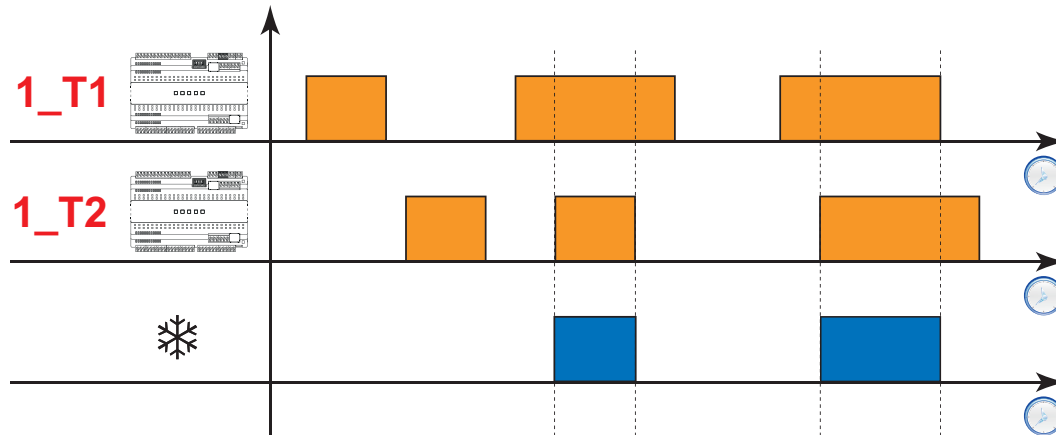

Legend: 1_T1 represents the progress of the probe set as thermostat 1 and 1_T2 represents the progress of the probe set as thermostat 2.

The 2 regulators are managed using the following parameters:

First regulator:

- **rP1:** regulation probe 1 setting
- **SP1:** first regulator setpoint setting
- **dF1:** first regulator differential setting
- **HC1:** first regulator heat/cool mode setting

Second regulator:

- **rP2:** regulation probe 2 setting
- **SP2:** second regulator setpoint setting
- **dF2:** second regulator differential setting
- **HC2:** second regulator heat/cool mode setting

Dual Thermostat in parallel regulation

This regulator only activates the production of cold/heat if both thermostats are active, and deactivates it when both of the two thermostats are satisfied (combined cabinet: island and upright).

In the event of a probe error on one or both thermostats, regulation will use the probe error parameters.

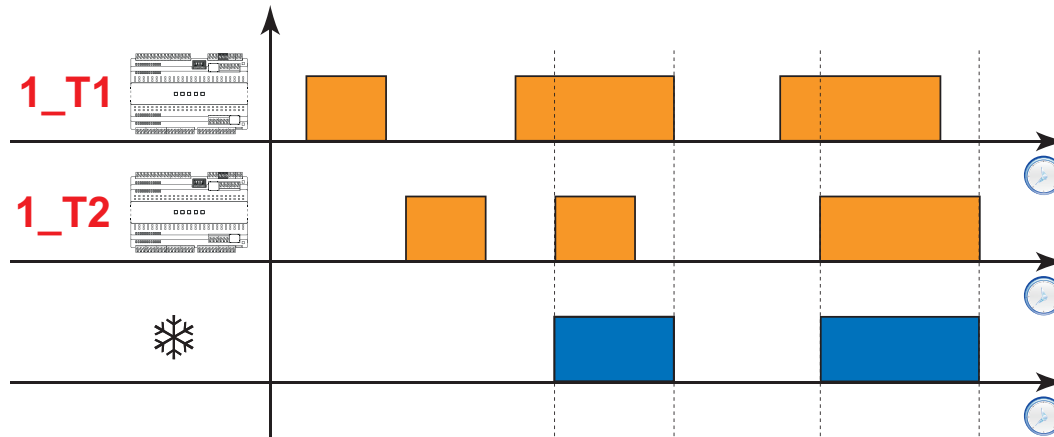

Legend: 1_T1 represents the progress of the probe set as thermostat 1 and 1_T2 represents the progress of the probe set as thermostat 2.

The 2 regulators are managed using the following parameters:

First regulator:

- **rP1:** regulation probe 1 setting
- **SP1:** first regulator setpoint setting
- **dF1:** first regulator differential setting
- **HC1:** first regulator heat/cool mode setting

Second regulator:

- **rP2:** regulation probe 2 setting
- **SP2:** second regulator setpoint setting
- **dF2:** second regulator differential setting
- **HC2:** second regulator heat/cool mode setting

Regulation with 2 Independent Regulators

This regulator only activates the production of heat/cold if both thermostats are active and

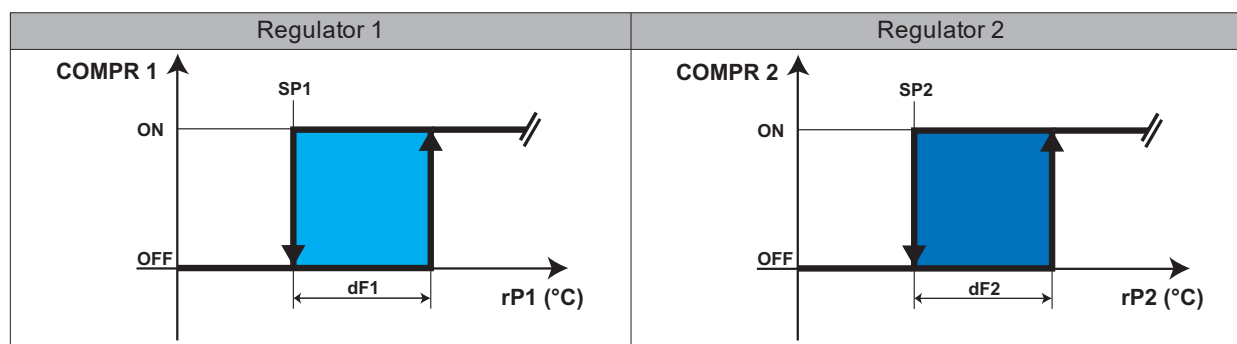

The first regulator implements output **COMPR 1**, which depends on the values and parameters indicated in the diagram, as well as the compressor safety timings.

The second regulator implements output **COMPR 2**, which is not necessarily a compressor, but a generic auxiliary output, not subject to the timings described by parameters **Cit**, **CAt**, **dOn**, **dOF**, **dbi**.

The second regulator:

- can work in both Heat and Cool modes
- has its own setpoint (**SP2**) and its own differential (**dF2**)
- has no safety timing, except for the timing **OdO**
- in the event of a probe error, the output will be permanently off

This regulator is independent from the other regulators, except the stand-by function, in which the output is deactivated. It can be used, for example, to manage the light on the basis of a light sensor connected to one of the 5 analog inputs Pb1...Pb5.

Note: in the latter case, set the setpoint **SP2** and differential **dF2** according to the transcoding tables associated with the compatible sensors. For assistance in choosing sensors, please contact Eliwell.

The 2 regulators are managed using the following parameters:

First regulator:

- **COMPR1:** (**Compressor**; H21...H27 = 1) output progress relating to the first regulator
- **rP1:** regulation probe 1 setting
- **SP1:** first regulator setpoint setting
- **dF1:** first regulator differential setting
- **HC1:** first regulator heat/cool mode setting

Second regulator:

- **COMPR2:** (**AUX**; H21...H27 = 5) output progress relating to the second regulator
- **rP2:** regulation probe 2 setting
- **SP2:** second regulator setpoint setting
- **dF2:** second regulator differential setting
- **HC2:** second regulator heat/cool mode setting

Regulation in the event of probe error

In the event of a probe error on the first regulator, and/or the second regulator if using dual thermostat mode, the output will be managed in accordance with parameters **Ont** and **OFt**.

Energy Saving regulation

Energy Saving mode can be activated in one of the following ways:

- via digital input (if suitably configured)
- via key (if suitably configured)
- remotely (directly via the supervision system)
- via RTC (if suitably configured)
- via Link².

During this mode, offsets **OS1** and **OS2** will be added to regulation setpoints **SP1** and **SP2**. If the second regulator is active, the offset will also be added to it.

Note: if you do not want the Offset to be added to the second regulator as well, set **OS2** = 0.

During this mode, the differential value on which to work will also be changed, **df1** will be replaced by **dn1** and **df2** by **dn2**. If the second regulator is active, the differential will also be added to it.

Note: if you do not want to change the value of the differential during Energy Saving mode, set **dn1** = **df1** and **dn2** = **df2**.

Dynamic Setpoint regulation

If the dynamic setpoint is active (inactive during Energy Saving), it is possible to increase or decrease the setpoint for value **Od1** (for setpoint 1) and **Od2** (for setpoint 2) when the door remains shut for a specific amount of time (defined by parameter **Cdt**).

As soon as the door remains open for a time defined by **Eso** within the space of one hour (not necessarily continuous, but rather cumulative) the normal setpoint value is restored.

Parameter **Eso** can be used to set the deactivation "threshold":

- **Eso** = 0: high usage before deactivation
- **Eso** = 10: low usage before deactivation

The function is active if parameter **Cdt** ≠ 0 and if a DI is configured as door switch. If the auxiliary regulator is active, the offset will also be added to it.

Note: if you do not want the Offset to be added to the second regulator as well, set **Od2** = 0.

Below is a graph showing how the algorithm works. The settings are:

- **ESt** = 2
- **H11** = 8
- **ESF** = yES (enabled when "Energy Saving" mode is enabled).

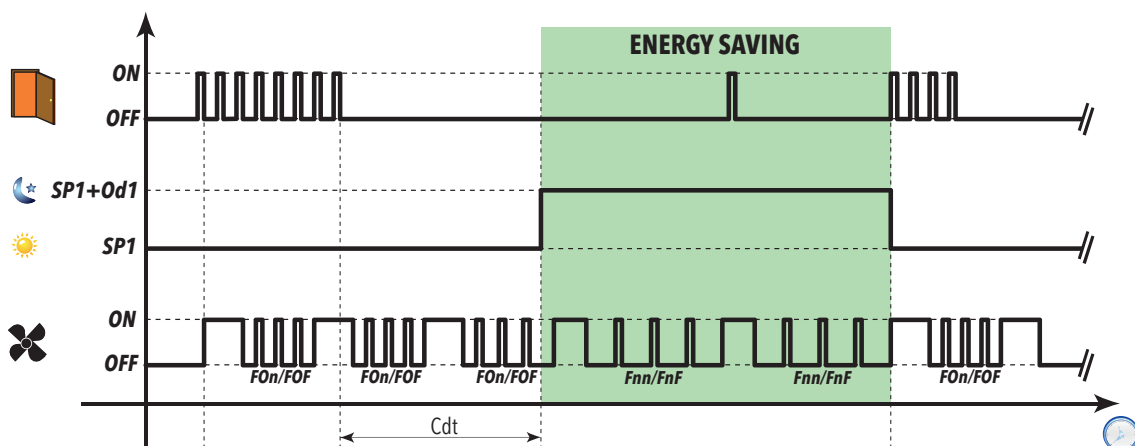

Remote Offset (only managed by Supervisor)

Serial commands can be used to increase/decrease the current value of the regulation setpoint for **OF1** (this will be added to setpoint **SP1** and any offset **OS1** or **Od1**).

Note: This increase/decrease only applies to the first setpoint (**SP1**).

This function is typically used for hot gas defrost systems, where it is necessary to have a certain number of counters supplying cooling, so as to ensure there is a sufficient amount of hot gas to perform defrosting as efficiently as possible.

Evaporator Fans

Operating conditions

The evaporator fan regulator is activated if the following conditions occur:

- The time set using parameter **OdO** has elapsed (if **OdO** ≠ 0).
- The temperature read by the evaporator probe is lower than the value of parameter **FSt**.
- Parameter **dFd** is not excluded during the defrost (**dFd** = On).
- Dripping is not active (**dt**).
- Fan delay after defrost is not active (**Fdt**).

Regulator activation

The request for fan activation or deactivation can take place in the following ways:

- from the compressor regulator, to assist in cooling (temperature control mode)
- from the defrost regulator, to control and/or limit the circulation of warm air.

Fan operating modes

Probe	FCO	Day		Night	
		Compressor ON	Compressor OFF	Compressor ON	Compressor OFF
Present	0	Thermostat controlled	Off	Thermostat controlled	Off
	1	Thermostat controlled	Thermostat controlled	Thermostat controlled	Thermostat controlled
	2	Thermostat controlled	Thermostat controlled	Thermostat controlled	Night duty cycle
	3	Thermostat controlled	Day duty cycle	Thermostat controlled	Night duty cycle
	4	Thermostat controlled	Day duty cycle REV**	Thermostat controlled	Night duty cycle REV**
Absent	0	On	Off	On	Off
	1	On	On	On	On
	2	Day duty cycle	Day duty cycle*	Night duty cycle	Night duty cycle*
	3	On	Day duty cycle*	On	Night duty cycle*
	4	On	Day duty cycle REV**	On	Night duty cycle REV**
In error	0	Day duty cycle	Off	Night duty cycle	Off
	1	On	Off	On	Off
	2	Day duty cycle	Day duty cycle	Night duty cycle	Night duty cycle
	3	Day duty cycle	Day duty cycle	Night duty cycle	Night duty cycle
	4	Day duty cycle	Day duty cycle	Night duty cycle	Night duty cycle

- (*): See section "Fan operation without probe"
- (**): Reverse operation of normal Duty cycle.

The graphs below illustrate fan operation in accordance with the value of **FCO**.

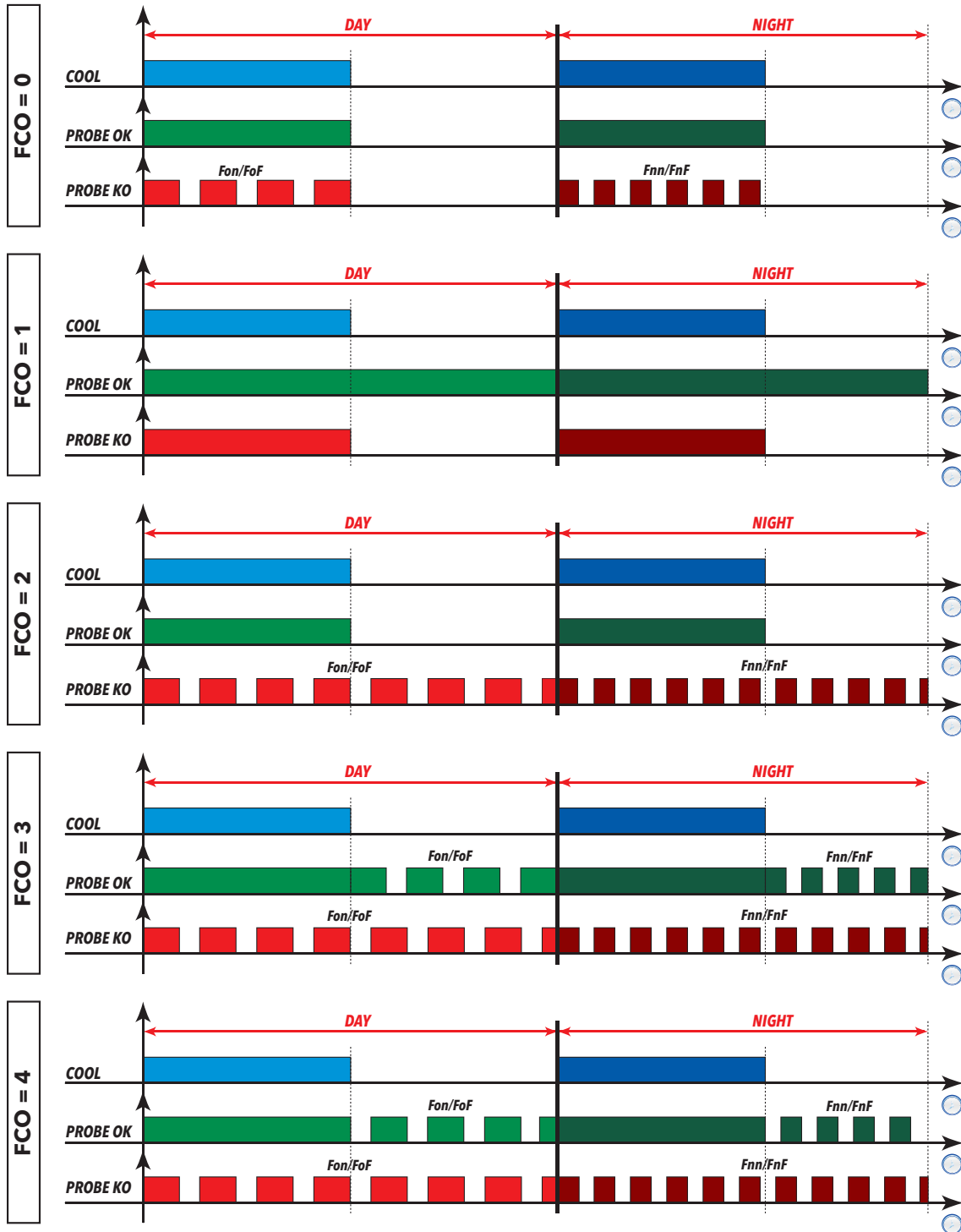

Legend: DAY = Day; NIGHT = Night; COOL = Cooling; **Probe OK** = Fan operation with probe present and working; **Probe KO** = Fan operation with probe present but in error.

Fan operation in temperature control mode

During cooling, fan temperature control is carried out based on values **FSt** (fan disabling temperature) and **FAd** (fan differential). Parameter **FPt** can be used to select whether the set temperature values are absolute or relative to the setpoint.

Note: around the fan start temperature -50°C (-58°F), the differential will always be specified by **FAd** but with the sign inverted.

Regulation diagrams based on whether the values are absolute or relative are shown below:

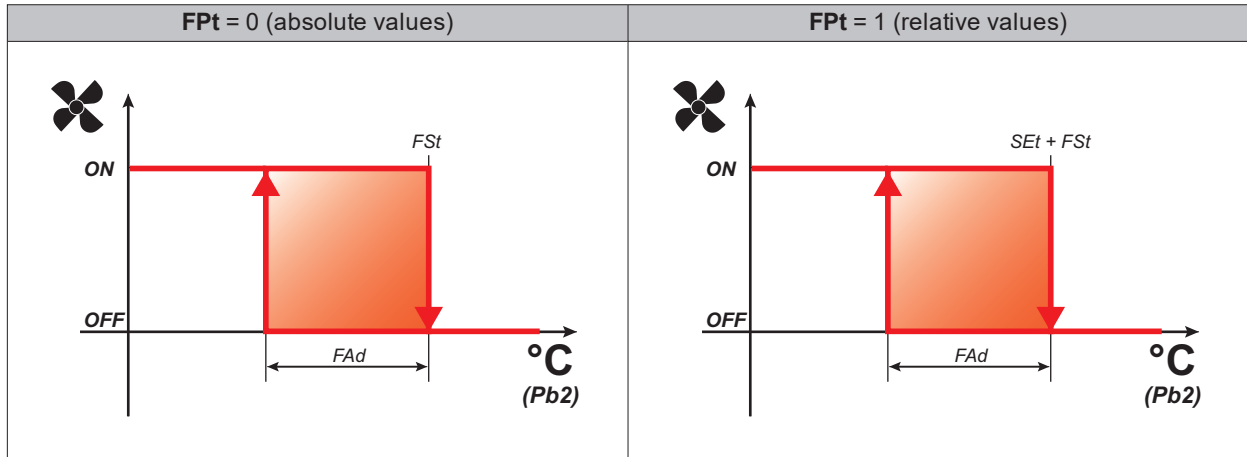

The regulation probe can be:

- One used for normal regulation and defrost (**FP1**≠0 and **FP2**=0)
- A specific probe for normal regulation and another during the defrost phase (**FP1**≠0 and **FP2**≠0).

The fans may be inhibited:

- during defrost
- if a digital input is configured as door switch.

When the evaporator fans are enabled during defrost (**dFd**=On) and the corresponding probe enters error status, the fans are kept running.

If the evaporator probe is not present, and **dFd**=On, the evaporator fans are active during defrost. Energy saving (night) mode is only active if enabled via parameter **ESF** when the controller is in Energy Saving mode.

Fan operation in duty cycle

The fans run in duty cycle mode when the compressor is off and this mode is specified by parameter **FCO**.

Activation of **Night** mode depends on parameter **ESF**:

- **ESF=no**: Night Mode disabled
- **ESF=yES**: Night Mode active when Energy Saving mode enabled

Depending on whether the controller is in day or night mode, fan operation is based on parameters **Fon** and **FoF** (day) or **Fnn** and **FnF** (night):

Fon / Fnn	FoF / FnF	Fans
0	0	Off
0	≠0	Off
≠0	0	On
≠0	≠0	Duty cycle

Regulation diagram for Day duty cycle with compressor off

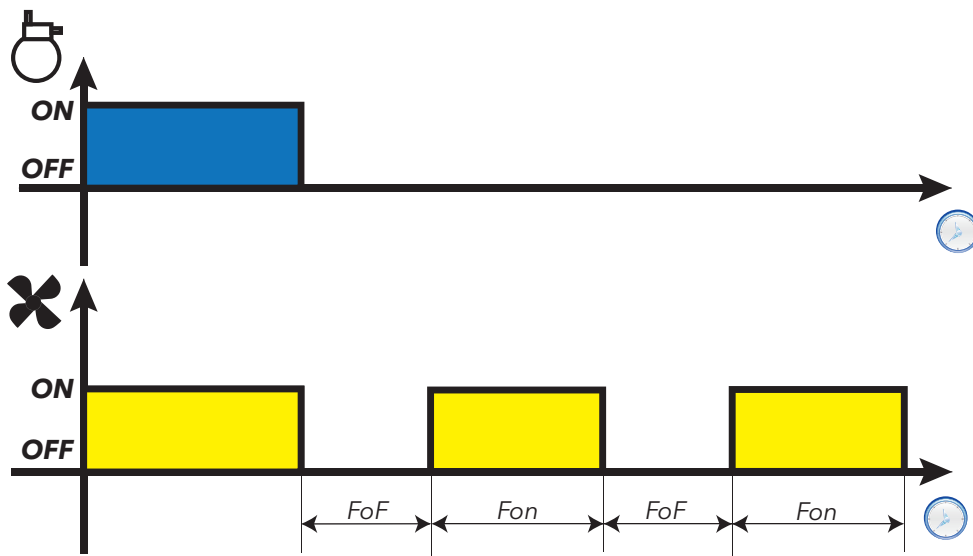

Regulation diagram for Night duty cycle with compressor off

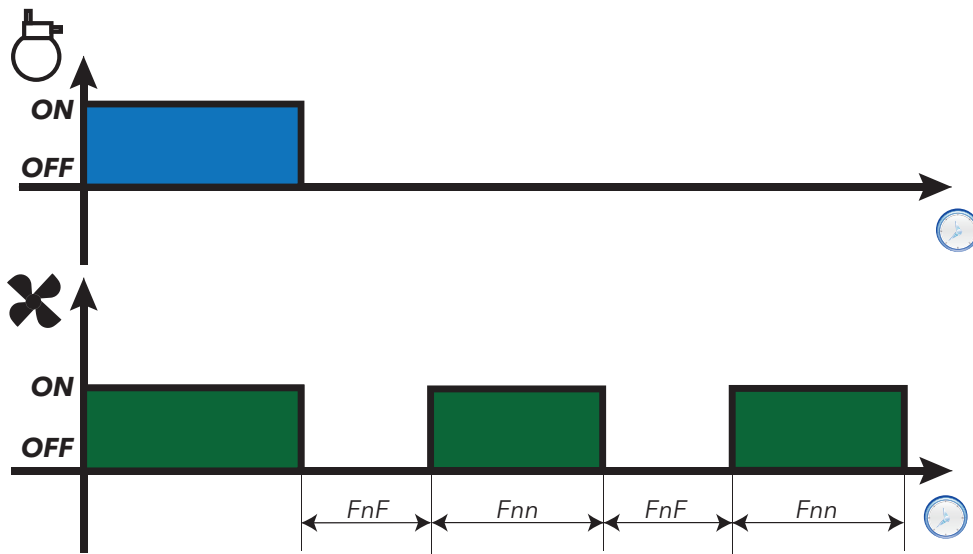

Fan operation in defrost mode

Operation depends on parameter **dFd**:

- **dFd=OFF**: Fans off during defrost
- **dFd=On**: Fans on during defrost (Temperature control or Duty cycle)

During cooling, fan temperature control is carried out based on values **FSt** (fan disabling temperature) and **FAd** (fan differential). Parameter **FpT** can be used to select whether the set temperature values are absolute or relative to the setpoint.

Note: in the case of “Electric heater” defrost, the compressor is OFF but the fans work as though the compressor was ON. To exclude the fans during a defrost, you must set **dFd=OFF**

When the evaporator fans are enabled during defrost (**dFd=On**) and regulate the evaporator probe in thermostat controlled mode, when the latter assumes error status it keeps the fans running constantly regardless of the values set by the Duty cycle.

Fan operation without probe

If the evaporator probe is absent, depending on the value of parameter **FCO** and the compressor status, the fans may be “On”, “Off”, in Duty cycle (Night or Day). Parameter **FCO** will determine the operating mode of the evaporator fans.

Below is an example of fan operation based on the value set by **FCO**.

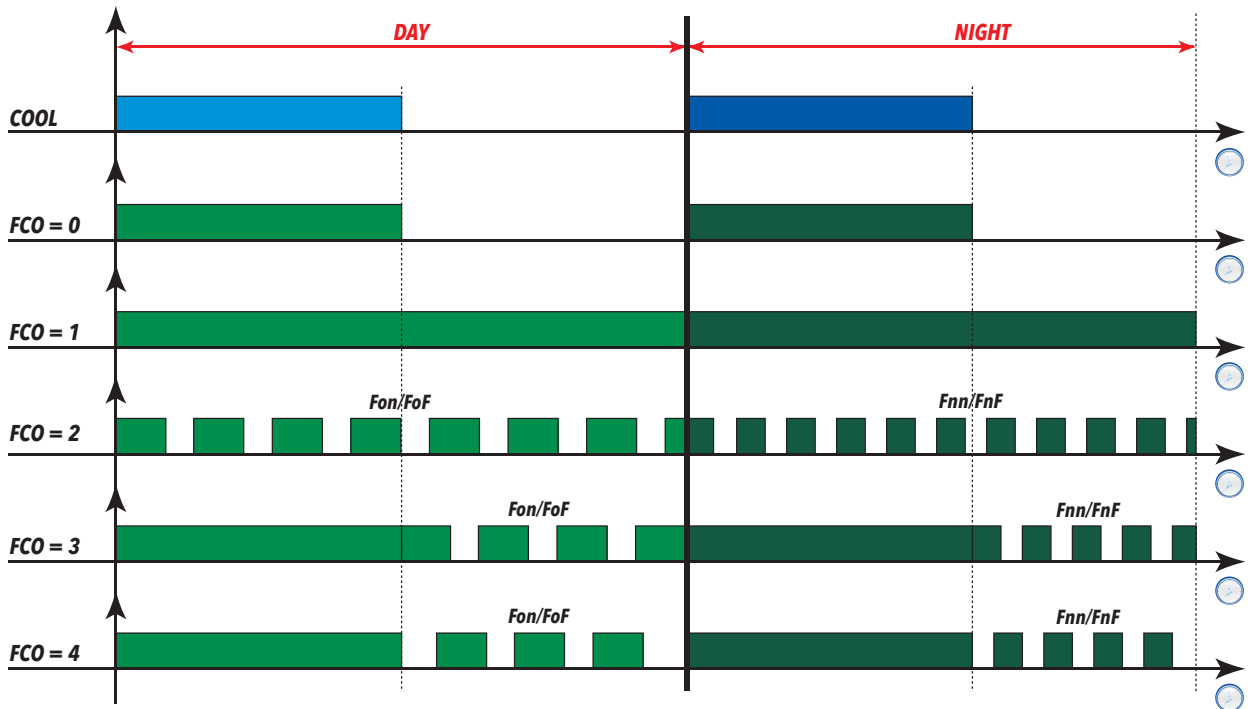

Fan operation in dripping mode

During dripping the fans remain stopped for the time set using parameter **dt**.

Note: if **Fdt** is greater than **dt** the fans remain off for the time set in **Fdt**.

Post-ventilation

Parameter **FdC** delays fan deactivation after the compressor has stopped. If **FdC** = 0 the function is excluded.

Parameters

Parameter	Description
OdO	Output activation delay from startup
FPt	Sets whether parameter FSt is expressed as an absolute value or as a value relative to the Setpoint
FSt	Evaporator fan disabling temperature
Fdt	Evaporator fan activation delay time after a defrosting cycle
dFd	Evaporator fan exclusion during a defrost cycle
FCO	Evaporator fan operating mode
FdC	Evaporator fan shutoff delay after compressor deactivation
FAd	Evaporator fan trigger differential
dt	Dripping time
Fon	Evaporator fan ON time in day duty cycle mode
FoF	Evaporator fan OFF time in day duty cycle mode
Fnn	Evaporator fan ON time in night duty cycle mode
FnF	Evaporator fan OFF time in night duty cycle mode
ESF	Night mode activation

Modulated Fans

Description

This analog regulator is used to manage the modulated fans applied to the evaporator or condenser and provides an implementation percentage to be applied to the analog output (on the basis of parameter **H51**)

Parameter **FE1** can be used to:

- select the probe to apply to the regulator (temperature probe or pressure transducer)
- disable the Modulated Fan regulator (**FE1=dis**)

The regulation setpoint can be absolute or relative:

- Absolute if **FEt = AbS** and the setpoint will be the value of: **FES**
- Relative if **FEt = rEL** and the setpoint will be the value of: **FES + Setpoint 1 (Regulator 1)**

Operation examples

The analog output (indicated in the diagrams with **AO**), is calculated as (to keep things simple, we have illustrated the mode associated with **FEt=AbS**).

Se **FEt=rEL**, replace the value **FES** with (**FES + Setpoint 1**):

Day mode:

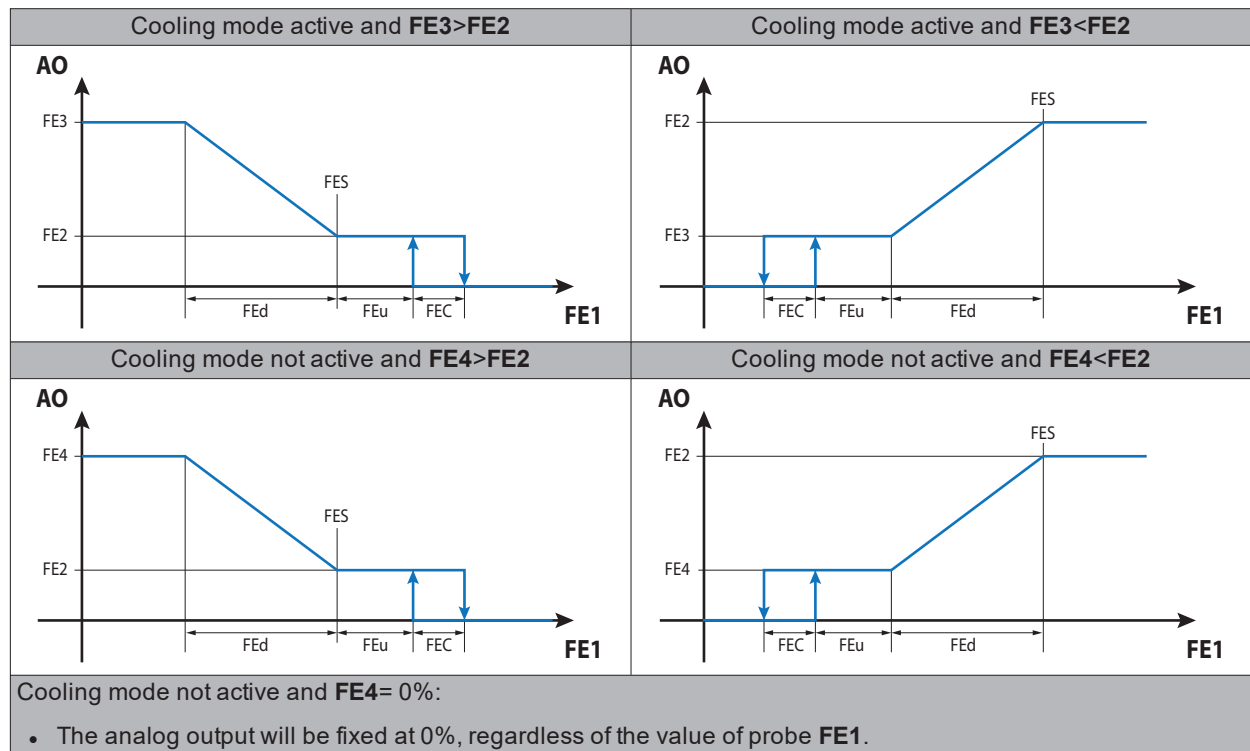

Night mode:

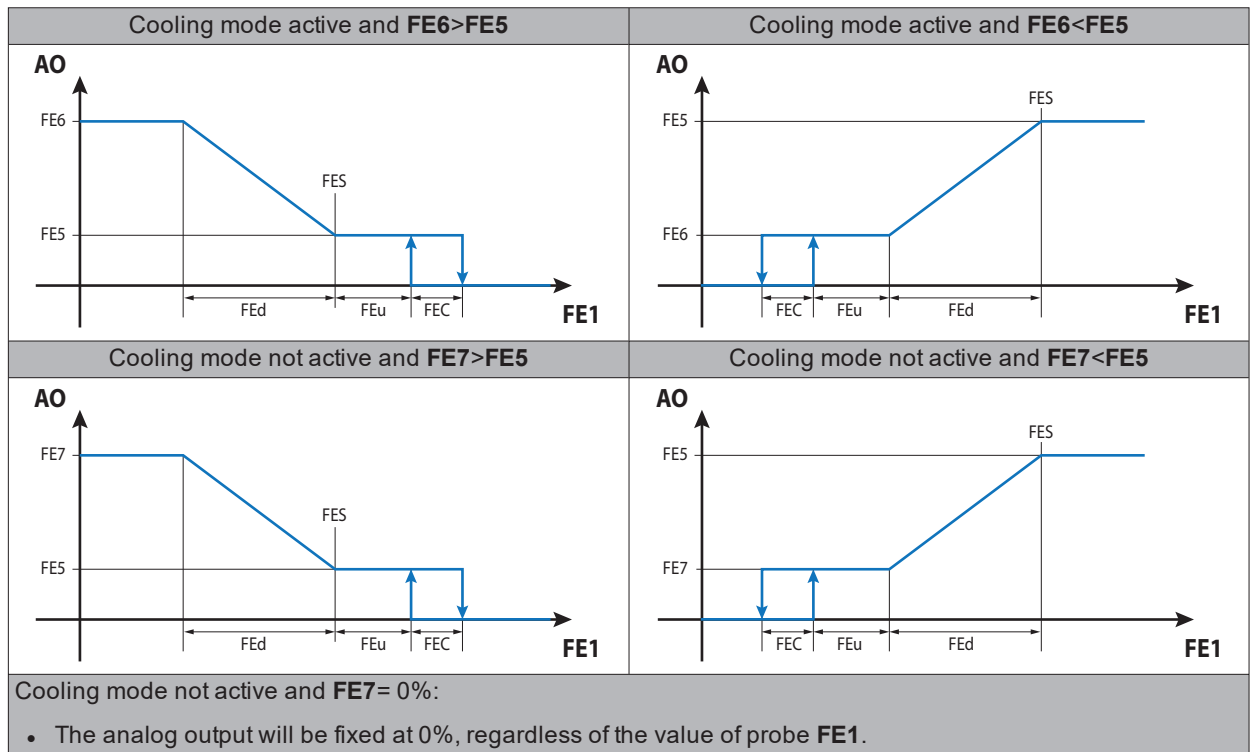

Regulation with probe error

In the event of a probe error, the analog output will assume the following values:

Condition	Day		Night (Energy Saving)	
	Cooling ON	Cooling OFF	Cooling ON	Cooling OFF
$FE4 > 0\%$	$FE9$	$FE9$	---	---
$FE4 = 0\%$	$FE9$	0%	---	---
$FE7 > 0\%$	---	---	$FE9$	$FE9$
$FE7 = 0\%$	---	---	$FE9$	0%

During the defrost phase the output will be set to the value set by parameter FE8.

During dripping (with a duration dt) the output will be set to 0%.

If the analog output mode at 0% is selected with cooling off ($FE4=0\%$ and/or $FE7=0\%$), the analog output can be kept active during post-ventilation FEr, as long as the analog output is > 0% when cooling is off, otherwise they will maintain 0%. During the time period FEr the cut-off is disabled.

Pick-up mode can be activated:

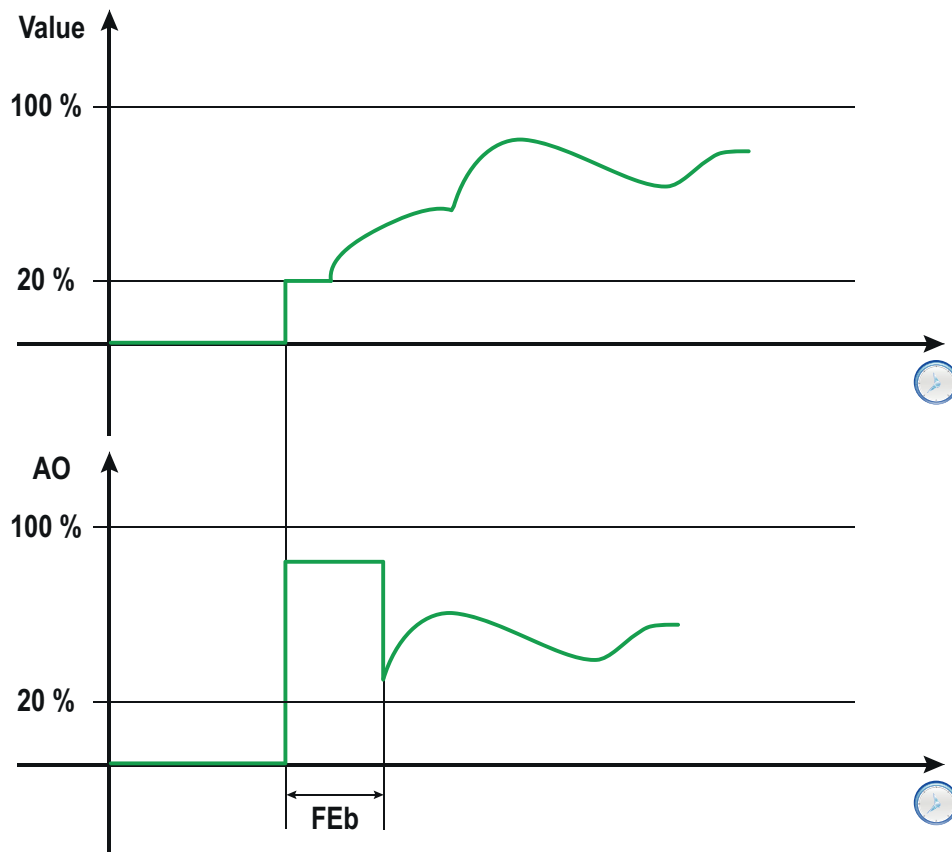

Prolonged use of the fans can reduce their performance and/or increase heating. Pick-up mode can be activated regularly for a time period **FEP**.

During "Counter cleaning" mode, the modulated fans are forced to percentage **FE3**

Parameters

Parameter	Description
FE1	Sets the probe for the modulated fans.
FEt	FES parameter mode.
FES	Modulated fan disabling temperature.
FEd	Modulated fan differential
FEu	Cut-OFF (0 = disabled)
FEC	Cut-OFF differential
FEr	Fan switch-off delay from compressor stop
FE2	Minimum Day percentage
FE3	Maximum Day percentage with compressor on
FE4	Maximum Day percentage with compressor off
FE5	Minimum Night percentage
FE6	Maximum Night percentage with compressor on
FE7	Maximum Night percentage with compressor off
FE8	Percentage during defrost
FE9	Percentage in the event of probe error
FEA	Fan pick-up percentage (0 = mode disabled)
FEb	Fan pick-up time
FEP	Fan forcing period at pick-up speed (0 = mode disabled)

Condenser Fans

Operating conditions

The condenser fan regulator and pre-ventilation are enabled if - and only if - a digital output is configured as a condenser fan output (**H2x** = ±11).

The condenser fans are active if at least one compressor is active.

Note: if the compressor is on in defrost (**dtty**=1 and **dtty**=2) and parameters **CFP**≠0 (Pre-ventilation time) and **CFd**=OFF (Condenser fan mode), in line with the end of defrost, the fans come on and the compressors switch off for the duration of the preheat phase (**CFP**).

Note: if the compressor is off in defrost (e.g. **dtty**=0) and parameters **CFd**=On, regulation has priority during defrost and, even if **CFd**=On (fans on), the fans are switched off as come required by the regulator.

Parameters

Parameter	Description
dtty	Defrost type. 0 = electric heater defrost 1 = cycle inversion defrost 2 = hot gas defrost for plug-in applications 3 = hot gas defrost for applications with remote group 4 = smart defrost.
CFP	Pre-ventilation time.
CFd	Condenser fan mode during defrosting.

Preheating

Description

The Preheat function can be a digital input with **H1x = ±9** or **i0x = ±9**.

While the preheat output is active:

- the compressor output and evaporator fans are off
- the compressor icon (❄) will flash.

If the function is activated during defrost, Preheat can continue as normal, except in the defrost modes which need the compressor to be on, i.e.:

- Cycle inversion defrost (**dt**y= 1)
- Hot gas defrost for plug-in applications (with built-in compressor) (**dt**y= 2).

Energy Saving

Description

Energy Saving mode (sometimes also called night operation) can be used to activate a series of functions that help to reduce consumption during closure periods.

Operating conditions

The Energy Saving function can be activated in one of the following ways:

- press and hold a key with **H3x = 4**
- activating a digital input with **H1x = ±4** or **i0x = ±4**
- via RTC by setting an event
- using a Supervisor, via Modbus command (serial)
- via Link2 network

Light and shutter output (AUX) management can take place in the following way:

- press and hold a key with **H3x = 5**
- activating a digital input with **H1x = ±5** or **i0x = ±5**
- via RTC by setting an event
- using a Supervisor, via Modbus command (serial)
- via Link2 network

For the “evaporator fans” and the “anti-condensation heaters”, refer to the relevant sections.

On activation of the Energy Saving function there will be:

- a change in the weighted average of the virtual regulation / switching probe
- an increase in the setpoint (reduced setpoint)
- a change in the regulation differential
- a modulation of the evaporator fans when the setpoint has been reached
- a reduction in the power supplied by the heating elements (anti-condensation)

Virtual probe / changing the probe

The device, in addition to regulating the values detected by the individual probes, can also regulate according to a weighted average of the value read by two probes (regulation probe and virtual probe):

- Virtual probe in Day mode:

$$\text{Virtualprobe} = [(probe1) * H72 + (probe2) * (100 - H72)] / 100$$

- Virtual probe in Energy Saving mode (Night):

$$\text{Virtualprobe} = [(probe1) * H72 + (probe2) * (100 - H72)] / 100$$

In the formula, probe 1 is selected via parameter **H70**, and probe 2 via parameter **H71**. Changing the regulation probe, between Day and Night - Energy Saving - mode, can be carried out by setting **H72=100** and **H73= 0**:

- Virtual probe in Day mode: **Probe 1**
- Virtual probe in Energy Saving mode (Night): **Probe 2**.

Parameters

Parameter	Description
H70	Sets 1st probe to use as a virtual probe.
H71	Sets 2nd probe to use as a virtual probe.
H72	Sets the calculation % used by the virtual probe in day mode.
H73	Sets the calculation % used by the virtual probe in night mode.

Deep Cooling Cycle (DCC)

Description

During the deep cooling cycle, the compressor runs with a setpoint equal to **dCS** and differential equal to **dF1** for a maximum time period **tdc**.

Activation

A deep cooling cycle can be activated in one of the following ways:

- press and hold a key with **H3x = 7**
- activating a digital input with **H1x = ±13** or **i0x = ±13**
- using a Supervisor, via Modbus command (serial)
- via Link2 network

In the event of a probe error and/or lack of power, the DCC ends and the device resumes standard operation.

Note: If parameters **dCS**, **tdc** and **dcc** are changed, DCC operation is recalculated with the new values set.

Operating conditions

When a deep cooling cycle is activated, defrosts are disabled.

At the end of the deep cooling cycle, after a delay of **dcc**, a defrost is forced and the count for interval **dit** begins again.

Exiting DCC takes place on the basis of time if parameter **tdc**≠0, or on reaching setpoint **dCS** if **tdc**=0. If **dcc**=0 the defrost takes place at the end of the DCC.

The deep cooling cycle ends automatically and standard regulation is resumed if:

- There is a probe error (the display shows **E2**).
- A blackout occurs and the controller switches off and on again.

If parameters **dCS**, **tdc** and **dcc** are changed during the deep cooling cycle, cycle operation should be recalculated for the new set values.

Regulation diagram

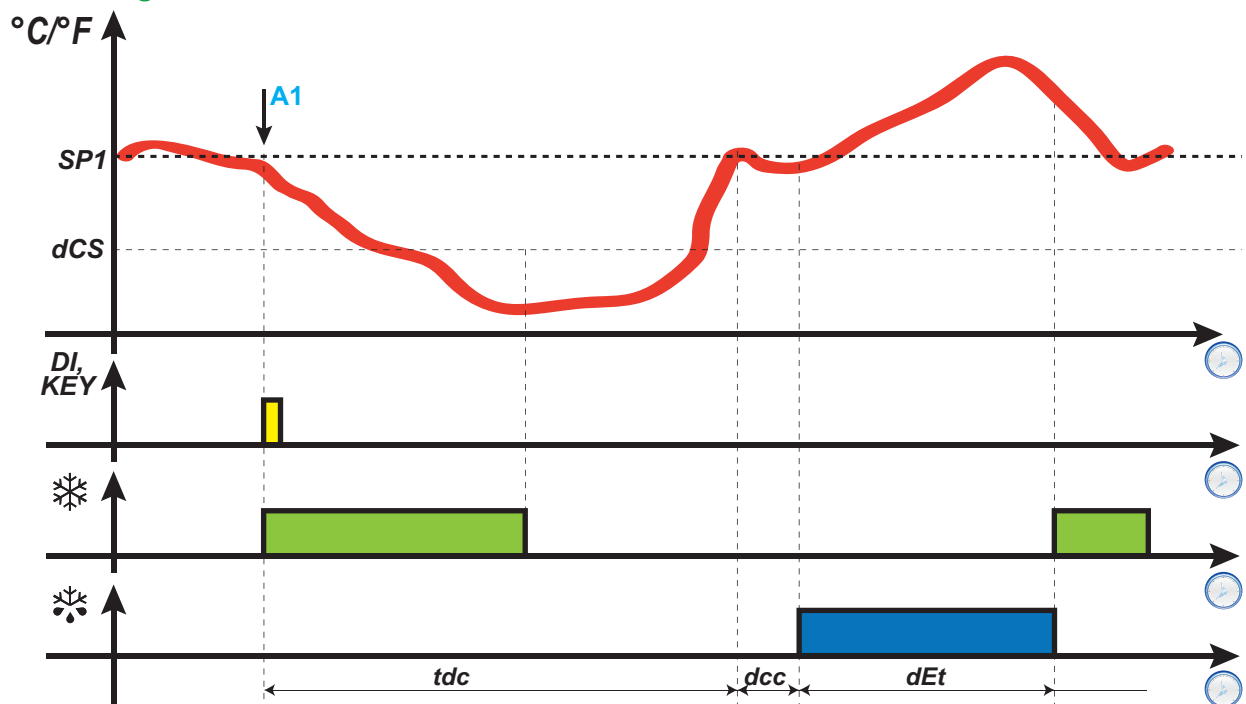

Legend: **A1** = DCC activation time; **DI** = Digital Input; **KEY** = Key.

Alarm operation during the deep cooling cycle

During the deep cooling cycle, the temperature alarms are disabled. Normal management is re-established at the end of the cycle, when the temperature read by **rP1** reaches the regulation setpoint value **SP1** again.

Parameters

Parameter	Description
SP1	Regulation setpoint.
dit	Interval between two consecutive defrosts
dCS	Deep cooling cycle setpoint
diF	Setpoint differential
tdc	Deep cooling cycle duration
dcc	Defrost activation delay after a "Deep Cooling Cycle"
H11...H18	Digital input 1...8 /polarity configuration.
i01...i02	Digital input 9 and 10 /polarity configuration (on KDX).
H31...H37	Key configuration.

Auxiliary Output (AUX)

Description

By setting a relay as an auxiliary output **AUX** with parameter **H2x**= 5 and pressing the key associated with **H3x** = 5, the relay activates if it was previously off and vice-versa. The status of the relay is stored in non-volatile memory, which means when the power is restored after a blackout the device resumes operation with the status it was in before the blackout occurred.

By setting a digital input with **H1x** = ± 5 or **i0x** = ± 5 , its activation will ensure that the relay mirrors the status of the digital input. In this case the relay status is not memorized.

Note: When the device is off, only the digital input and the associated key can change the status of the output.

Note: Always use the same activation mode for the relay set as AUX. For example, if the relay is activated via Digital Input and deactivated via key, when the Digital Input status changes, the relay will not change status as it has already been activated via key.

Activation

The auxiliary output (AUX) can be activated in one of the following ways:

- press and hold a key with **H3x** = 5
- activating a digital input with **H1x** = ± 5 or **i0x** = ± 5
- via RTC by setting an event
- using a Supervisor, via Modbus command (serial)
- via Link2 network

Note: During stand-by the regulator operates in accordance with parameter **H08**, while at startup it is deactivated.

Regulation diagram

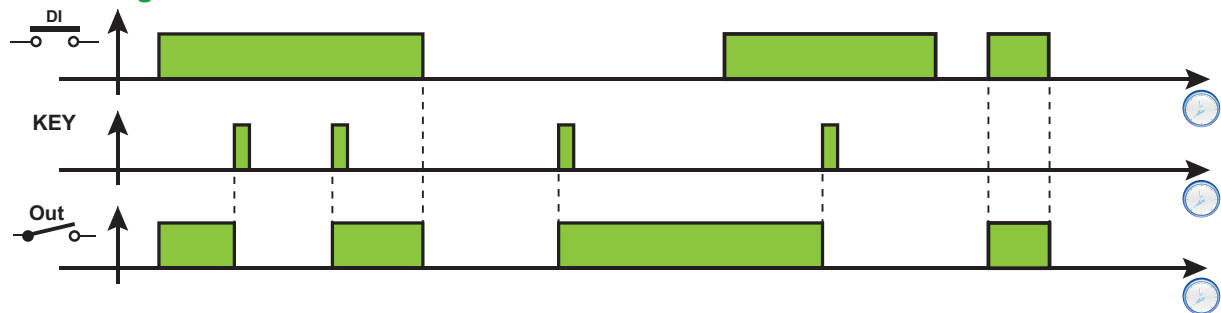

Legend: DI = Digital input; KEY = Key; Out = Digital output

Parameters

Parameter	Description
H08	Stand-by operating mode
H11...H18	Digital input 1...8 /polarity configuration.
i01...i02	Digital input 9 and 10 /polarity configuration (on KDX).
H21...H25	Configuration of digital outputs Out 1...Out 5
H31...H37	Key configuration.

Auxiliary Output (Light)

Description

By setting a relay as auxiliary output **Light** with parameter **H2x**= 7 and pressing the key associated with **H3x** = 3, the relay activates if it was previously off and vice-versa. The status of the relay is stored in non-volatile memory, which means when the power is restored after a blackout the device resumes operation with in the status it was in before the blackout occurred.

By setting a digital input with **H1x** = ± 3 or **i0x** = ± 3 , its activation will ensure that the relay mirrors the status of the digital input. In this case the relay status is not memorized.

Note: When the device is off, only the digital input and the associated key can change the status of the output.

Note: Always use the same activation mode for the relay set as Light. For example, if the relay is activated via Digital Input and deactivated via key, when the Digital Input status changes, the relay will not change status as it has already been activated via key.

Activation

The auxiliary output (Light) can be activated in one of the following ways:

- press and hold a key with **H3x** = 3
- activating a digital input with **H1x** = ± 3 or **i0x** = ± 3
- via RTC by setting an event
- using a Supervisor, via Modbus command (serial)
- via Link2 network

Note: During stand-by the regulator operates in accordance with parameter **H08**, while at startup it is deactivated.

Regulation diagram

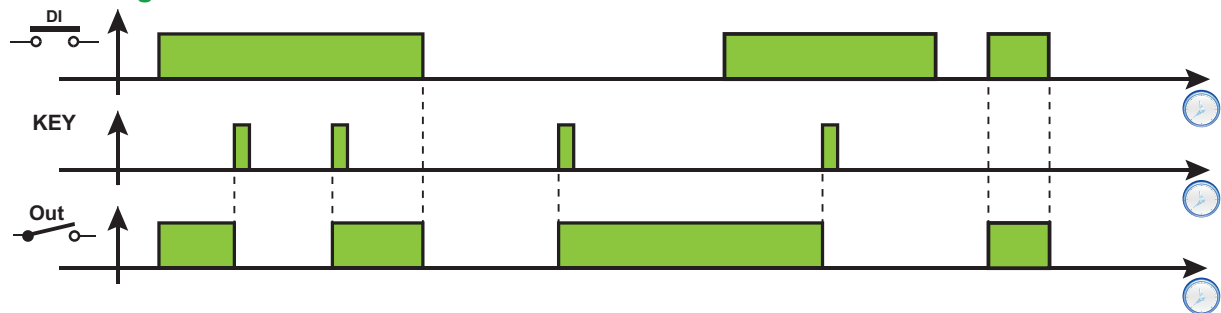

Legend: DI = Digital input; KEY = Key; Out = Digital output

Parameters

Parameter	Description
H08	Stand-by operating mode
H11...H18	Digital input 1...8 /polarity configuration.
i01...i02	Digital input 9 and 10 /polarity configuration (on KDX).
H21...H25	Configuration of digital outputs Out 1...Out 5
H31...H37	Key configuration.

Stand-by

Description

The stand-by function maintains the controller power supply and, depending on the value of parameter **H08**:

- switches off the display or shows **OFF**
- deactivates all regulators (or not)
- excludes alarms (or not)

Note: when the device is off, all the relays are de-energized except for the key and the digital input set as light or door switch.

Activation

The stand-by function can be activated in one of the following ways:

- press and hold a key with **H3x = 6**
- digital input (only if **H1x = ±7**)
- using a Supervisor, via Modbus command (serial)

When the device is switched on via key or digital input, regular device operation begins as at start-up.

Note: the digital input takes priority over the key. If both are configured, the key command will be excluded.

Operation

When the stand-by function is activated, depending on the setting for **H08**, the following will occur:

- **H08 = 0**: display off, the regulators remain active and the instrument can activate the alarm icon(🔔) when an alarm occurs
- **H08 = 1**: display off, all relays are de-energized and the alarms deactivated
- **H08 = 2**: the display shows the text **OFF**, all relays are de-energized and the alarms deactivated

On exiting stand-by function, the temperature alarm is excluded for the time period set with parameter **PAO**; the outputs are deactivated for the time period set with parameter **OdO**. The meters for parameters **PAO** and **OdO** are reset every time the controller is switched off.

If stand-by had been active when the controller was switched off (both as the result of a blackout and voluntarily), it will also be active the next time it is switched on.

Soft Start

Description

Soft Start requires the hot gas valve to open before compressor start-up to reduce the pressure differential. After compressor start-up the valve will be closed.

Operating conditions

The parameters involved in regulation are SS1 and SS2.

- **SS1**: sets the time (in seconds) between hot gas valve opening and compressor startup. This count starts as soon as all protection times relating to compressor power-on have elapsed.
- **SS2**: sets the time (in seconds) between compressor startup and hot gas valve closure.

Regulation diagram

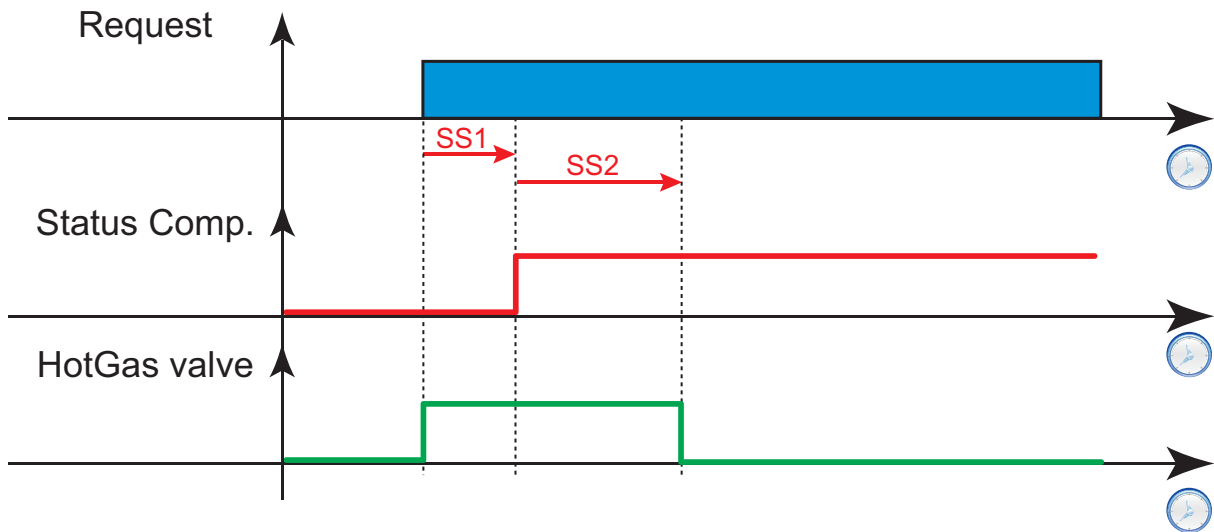

Legend: Request = Request cooling; Status Comp. = Compressor Status; HotGas valve = Hot Gas valve.

Pump down (Pump out)

Description

If parameter **POt**≠0, the compressor will continue to run for a time period **POt** (in seconds) after the evaporator valve closes.

Operating conditions

The liquid valve and the compressor will be active at the same time except:

- during the pump down / pump out phase
- during defrost

Regulation diagram

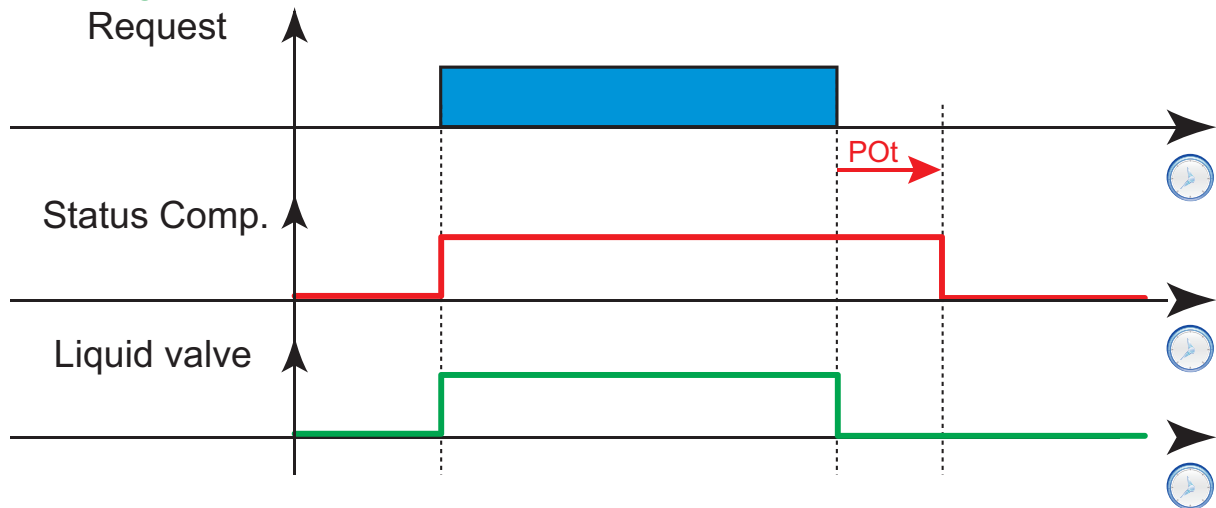

Legend: Request = Request cooling; Status Comp. = Compressor Status; Liquid valve = Liquid valve.

Compressor oil heater

Description

This is an ON-OFF type regulator. The heating element heating the compressor oil can be controlled with a dedicated thermostat and probe.

Operating conditions

The output configured as compressor oil heater (**H2x** = 15) will be off:

- if there is a probe error or the probe is not configured
- when the machine is in stand-by
- during the delay countdown **OdO** at startup

Regulation diagram

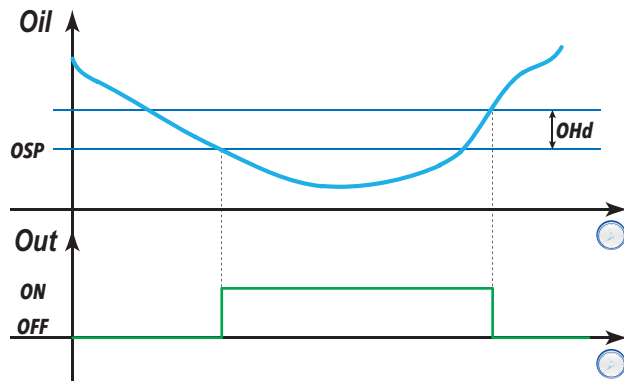

Parameters

Parameter	Description
OHP	Sets the regulation probe used.
OSP	Sets the regulation setpoint.
OHd	Sets the regulation differential.
OHS	Maximum value that can be set for the setpoint.
OLS	Minimum value that can be set for the setpoint.

Counter Cleaning Function

Description

This function is used for counter maintenance and:

- to activate the function
- advance along "Clean status 1" and "Clean status 2" (A and B) by pressing the associated key (H3x = 9).

Operating conditions

If activated, compressor 2 will use the same setpoint and differential as compressor 1. If offsets are applied to the setpoint and/or to the differential due to the energy saving function (or other conditions), the second compressor will also be influenced by these offsets.

During normal operation:

- Pressing the associated key (**KEY**) offers entry to "Clean status 1" mode (**A**) and:
 - fans on and all other loads deactivated
 - fan icon (**FAN**) on
 - display shows label **CLn**
- On pressing the associated key (**KEY**) a second time, the device switches to "Clean status 2" mode (**B**) and:
 - all loads are deactivated
 - display shows label **CLn**
- Pressing the associated key (**KEY**) a third time means the device exits the counter Cleaning Function and resumes normal operation.

Note: If there is no power, when the device is started up again it resumes normal operation (the function is canceled)

Regulation diagram

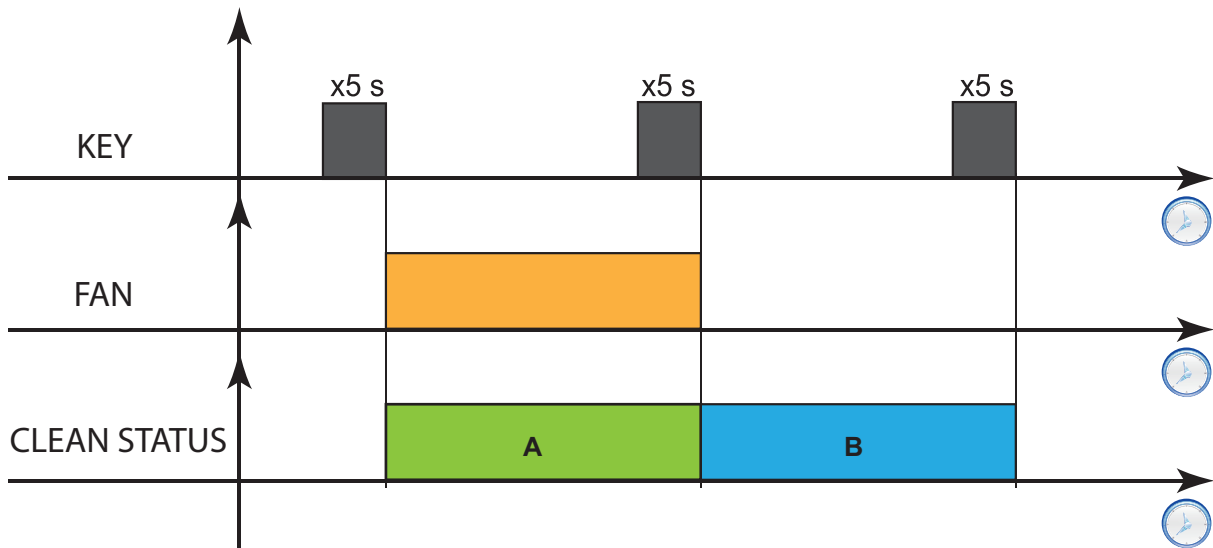

Legend: KEY = Key; FAN = Fans; CLEAN STATUS = Counter cleaning function

Practical examples

Contents

This section includes the following topics:

Floating suction for positive overheating ≥ 4 K)	143
Floating suction with low overheating (~ 0 K)	144

Floating suction for positive overheating ≥ 4 K)

Application

This example describes a “Floating suction for positive overheating” application managed using a **RTX 600 IV DOMINO ZERO** device.

If the device is connected to a **TelevisGo** and a **EWCM 9000 PRO DOMINO**, its “Floating Suction” control algorithm can be used (see relevant User Manual).

The **TelevisGo** will carry out the following steps:

- Reading the demand for all associated system evaporators originating from the device **RTX 600 IV**
- Calculating the increase / reduction in normal suction parameters within the limits
- Sending the normal suction pressure setpoint to the **EWCM 9000 PRO DOMINO** device

Diagram

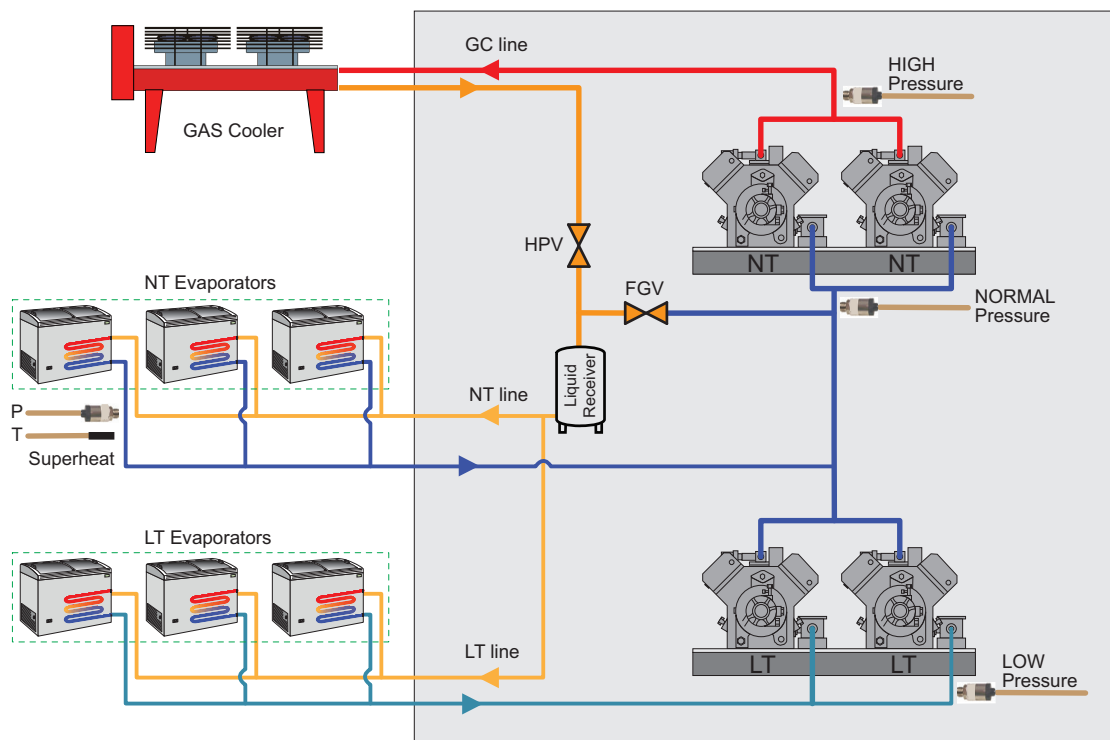

Legend:

- **Gas Cooler** = Gas Cooler
- **NT Evaporator** = Normal temperature evaporators
- **LT Evaporator** = Low temperature evaporators
- **Liquid Receiver** = Liquid receiver
- **Heat Exchanger** = Heat exchanger
- **HIGH Pressure** = High pressure transducer
- **NORMAL Pressure** = Normal temperature (NT) suction pressure transducer
- **LOW Pressure** = Low pressure transducer
- **Superheat** = Temperature sensor (T) and overheating pressure transducer (P)
- **GC** = Gas Cooler Line
- **NT line** = Normal temperature line
- **LT line** = Low temperature line
- **HPV** = High pressure valve
- **FGV** = Flash gas valve

Floating suction with low overheating (~ 0 K)

Application

This example describes a “Floating suction with low overheating and near-zero values” application managed using a **RTX 600 IV DOMINO ZERO** device.

If the device is connected to a **TelevisGo** and a **EWCM 9000 PRO DOMINO**, its “Floating Suction” control algorithm can be used (see relevant User Note).

The **TelevisGo** will carry out the following steps:

- Reading the demand for all associated system evaporators originating from the device **RTX 600 IV**
- Calculating the increase / reduction in normal suction parameters within the limits
- Sending the normal suction pressure setpoint to the **EWCM 9000 PRO** device

Wiring diagrams

Example 1: Regenerative exchanger in the liquid receiver.

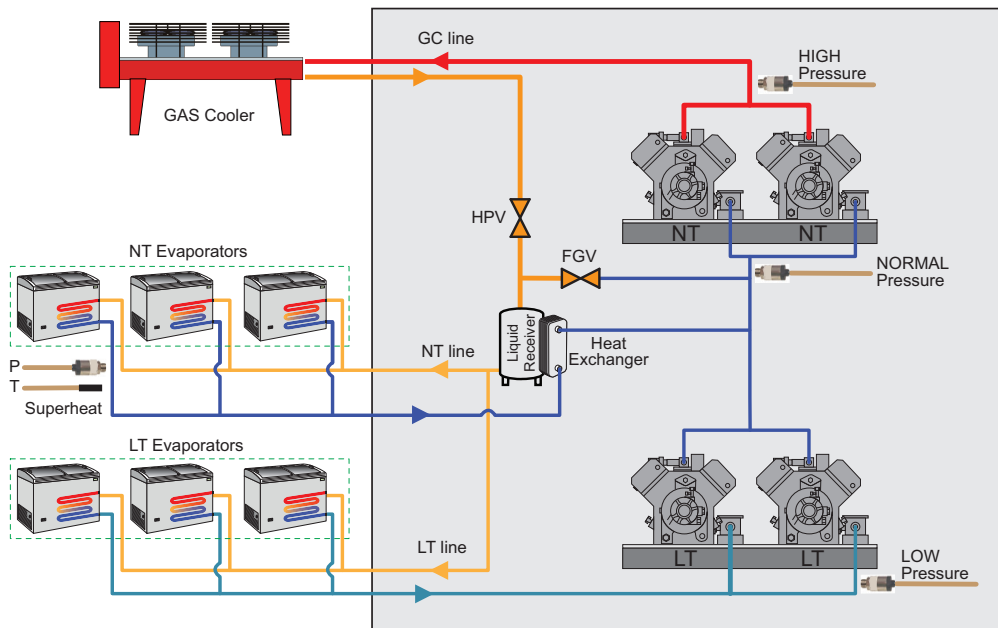

Example 2: Regenerative exchanger in series with the Gas Cooler.

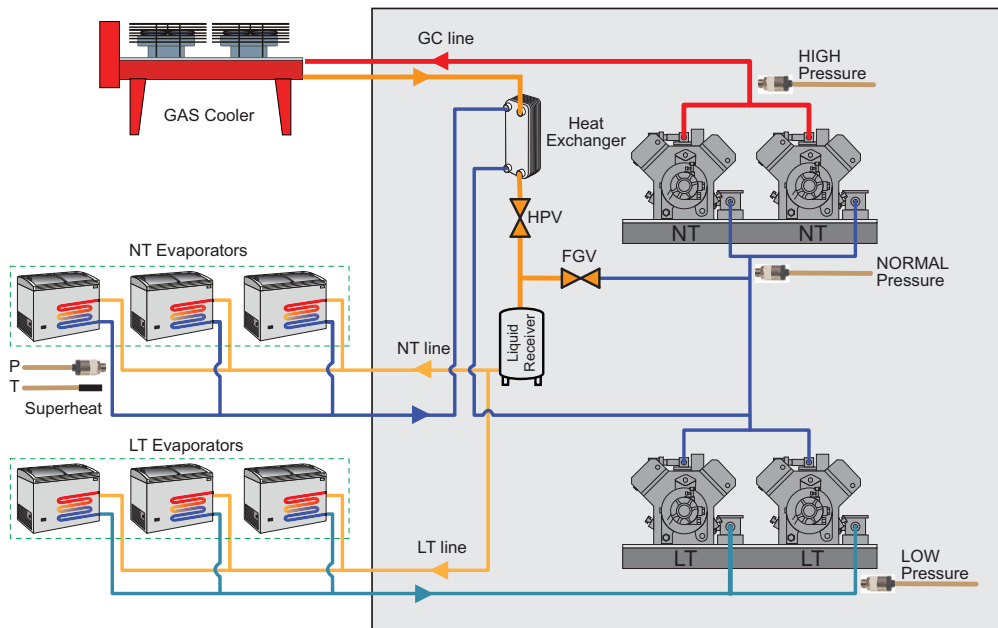

Example 3: Regenerative exchanger on the high pressure line.

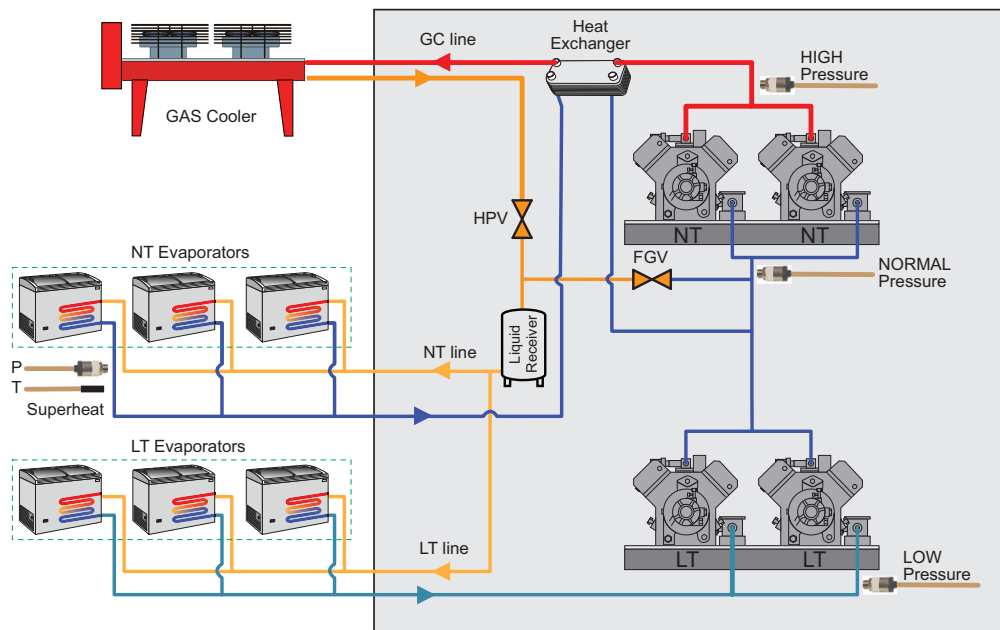

Legend:

- **Gas Cooler** = Gas Cooler
- **NT Evaporator** = Normal temperature evaporators
- **LT Evaporator** = Low temperature evaporators
- **Liquid Receiver** = Liquid receiver
- **Heat Exchanger** = Heat exchanger
- **HIGH Pressure** = High pressure transducer
- **NORMAL Pressure** = Normal temperature (NT) suction pressure transducer
- **LOW Pressure** = Low pressure transducer
- **Superheat** = Temperature sensor (T) and overheating pressure transducer (P)
- **GC** = Gas Cooler Line
- **NT line** = Normal temperature line
- **LT line** = Low temperature line
- **HPV** = High pressure valve
- **FGV** = Flash gas valve

Diagnostics

Contents

This section includes the following topics:

Alarms and indications	147
Probe alarms	150
Minimum and maximum temperature alarm	151
Defrost ended due to timeout alarm	153
External alarm	154
Door open alarm	155

Alarms and indications

Detecting an alarm condition

If there is an alarm condition, the alarm icon (●) comes on steadily. If present and enabled, the buzzer and alarm relay are also activated.

Note: If alarm exclusion timings are in progress, the alarm is not signaled.

All active alarms, except those relating to probe error, are listed in the **ALr** folder within the **"Machine status"** menu.

Alarms resulting from a probe error will be shown on the display by means of label E1...E8, EL or Ei depending on whether it concerns Pb1...Pb8, Link2 or the Virtual Probe respectively.

Silencing the buzzer

Press any key or use the menu function: the buzzer is silenced, the alarm icon (●) flashes and the alarm relay is de-energized.

Alarms legend

Code	Description	Cause	Effects	Solutions
E1	Probe Pb1 in error	<ul style="list-style-type: none"> Reading of values outside the operating interval Probe or corresponding wiring in short-circuit or open circuit 	<ul style="list-style-type: none"> E1 shown Steady alarm icon (●) 	<ul style="list-style-type: none"> Verify the probe type (H00). Verify the probe wiring. Replace probe.
E2	Probe Pb2 in error	<ul style="list-style-type: none"> Reading of values outside the operating interval Probe or corresponding wiring in short-circuit or open circuit 	<ul style="list-style-type: none"> E2 shown Steady alarm icon (●) 	<ul style="list-style-type: none"> Verify the probe type (H00). Verify the probe wiring. Replace probe.
E3	Probe Pb3 in error	<ul style="list-style-type: none"> Reading of values outside the operating interval Probe or corresponding wiring in short-circuit or open circuit 	<ul style="list-style-type: none"> E3 shown Steady alarm icon (●) 	<ul style="list-style-type: none"> Verify the probe type (H00). Verify the probe wiring. Replace probe.
E4	Probe Pb4 in error	<ul style="list-style-type: none"> Reading of values outside the operating interval Probe or corresponding wiring in short-circuit or open circuit 	<ul style="list-style-type: none"> E4 shown Steady alarm icon (●) 	<ul style="list-style-type: none"> Verify the probe type (H00). Verify the probe wiring. Replace probe.
E5	Probe Pb5 in error	<ul style="list-style-type: none"> Reading of values outside the operating interval Probe or corresponding wiring in short-circuit or open circuit 	<ul style="list-style-type: none"> E5 shown Steady alarm icon (●) 	<ul style="list-style-type: none"> Verify the probe type (H00). Verify the probe wiring. Replace probe.
E6	Probe Pb6 in error (4...20 mA)	<ul style="list-style-type: none"> Reading of values outside the operating interval Probe or corresponding wiring in short-circuit or open circuit 	<ul style="list-style-type: none"> E6 shown Steady alarm icon (●) 	<ul style="list-style-type: none"> Verify the probe type. Verify the probe wiring. Replace probe.
E7	Probe Pb7 in error (ratiometric)	<ul style="list-style-type: none"> Reading of values outside the operating interval Probe or corresponding wiring in short-circuit or open circuit 	<ul style="list-style-type: none"> E7 shown Steady alarm icon (●) 	<ul style="list-style-type: none"> Verify the type of probe (trA). Verify the probe wiring. Replace probe.
E8	Probe Pb8 on KDX in error (4...20 mA)	<ul style="list-style-type: none"> Reading of values outside the operating interval Probe or corresponding wiring in short-circuit or open circuit 	<ul style="list-style-type: none"> E8 shown Steady alarm icon (●) 	<ul style="list-style-type: none"> Verify the probe type. Verify the probe wiring. Replace probe.
EL	Link2 probe in error	<ul style="list-style-type: none"> Reading of values outside the operating interval Probe or corresponding wiring in short-circuit or open circuit 	<ul style="list-style-type: none"> EL appears Steady alarm icon (●) 	<ul style="list-style-type: none"> Verify the probe type. Verify the probe wiring. Replace probe.
Ei	Virtual probe in error	<ul style="list-style-type: none"> Reading of values outside the operating interval Probe or corresponding wiring in short-circuit or open circuit 	<ul style="list-style-type: none"> Ei appears Steady alarm icon (●) 	<ul style="list-style-type: none"> Verify the probe type. Verify the probe wiring. Replace probe.
AL1	Low temperature alarm 1	Value read by probe 1 < LA1 after time equal to tA1 (see section "Minimum and maximum temperature alarm" a pagina 151).	<ul style="list-style-type: none"> Alarm AL1 added to folder ALr No effect on regulation 	Wait for the temperature read by the probe selected with ra1 to rise above the alarm threshold (LA1+AFd).
AH1	High temperature alarm 1	Value read by probe 1 > HA1 after time equal to tA1 (see section "Minimum and maximum temperature alarm" a pagina 151).	<ul style="list-style-type: none"> Alarm AH1 added to folder ALr No effect on regulation 	Wait for the temperature read by the probe selected with ra1 to fall below the alarm threshold (HA1-AFd).

Code	Description	Cause	Effects	Solutions
AL2	Low temperature alarm 2	Value read by probe 2 < LA2 after time equal to tA2 (see section "Minimum and maximum temperature alarm" a pagina 151).	<ul style="list-style-type: none"> Alarm AL2 added to folder ALr No effect on regulation 	Wait for the temperature read by the probe selected with RA2 to rise above the alarm threshold (LA2+AFd).
AH2	High temperature alarm 2	Value read by probe 2 > HA2 after time equal to tA2 (see section "Minimum and maximum temperature alarm" a pagina 151).	<ul style="list-style-type: none"> Alarm AH2 added to folder ALr No effect on regulation 	Wait for the temperature read by the probe selected with RA2 to fall below the alarm threshold (HA2-AFd).
OPd	Door open alarm	Digital input activation (H1x = ±8 or i0x = ±8) for a time greater than tdo .	<ul style="list-style-type: none"> Alarm OPd added to folder ALr Steady alarm icon (●) Regulator inhibited, on the basis of parameter dod 	<ul style="list-style-type: none"> Close the door Increase the value of parameter OAO
EA	External alarm	Digital input activation (H1x = ±6 or i0x = ±6).	<ul style="list-style-type: none"> Alarm EA added to folder ALr Steady alarm icon (●) Regulation inhibited if EAL = y 	Verify and remove the external cause that caused the alarm on the digital input.
Prr	Preheat alarm	Preheat input regulator alarm active.	<ul style="list-style-type: none"> Prr shown Compressor icon flashing Regulation inhibited (compressor and fans) <p>Note: defrost will also be inhibited if it is cycle inversion or hot gas type.</p>	Preheat input regulator OFF.
Ad2	Defrost end due to timeout	End of defrost due to timeout, instead of the defrost end temperature being reached.	<ul style="list-style-type: none"> Alarm Ad2 added to folder ALr Steady alarm icon (●) 	Wait for the next defrost for automatic deactivation.
E10	Clock alarm	<ul style="list-style-type: none"> Clock (RTC) battery low RTC not working. 	<ul style="list-style-type: none"> Alarm E10 added to folder ALr Functions connected to the clock not present or not synchronized with the current timings 	Set the correct time. If the error persists, replace the instrument (RTC battery low)
E11	Power-Pack alarm	<ul style="list-style-type: none"> Power-Pack missing Insufficient voltage (Power-Pack charging) 	<ul style="list-style-type: none"> Alarm E11 added to folder ALr Steady alarm icon (●) Valve closure not guaranteed 	<p>FOR EXPERT USERS</p> <ul style="list-style-type: none"> Verify the Power-Pack is present (parameter Ety) Make sure the Power-Pack is inserted correctly wait for Power-Pack to charge/make sure it is properly charged
E13	Valve driver protection enabled	<ul style="list-style-type: none"> Incorrect valve connection Valve not working Overcurrent detected on valve inputs 	<ul style="list-style-type: none"> Alarm E13 added to folder ALr Steady alarm icon (●) Regulation inhibited 	<ul style="list-style-type: none"> Verify valve connection Make sure there are no short-circuits on the valve output.
E14	Alarm signaling no communication between base and expansion	Internal communication alarm	<ul style="list-style-type: none"> Alarm E14 added to folder ALr Steady alarm icon (●) Regulation inhibited 	<ul style="list-style-type: none"> Verify communication with supervision is working Make sure nothing is connected to the UNICARD/MFK connector.
E15	Power-Pack alarm	Power-Pack module not working.	<ul style="list-style-type: none"> Alarm E15 added to folder ALr Steady alarm icon (●) Valve closure not guaranteed 	<p>FOR EXPERT USERS</p> <ul style="list-style-type: none"> Verify the Power-Pack is present (parameter Ety) Replace the Power-Pack, wait for it to charge (alarm E11 reset) and close the valve by cutting off the power supply to the device
EEP	Valve MOP alarm	The saturation temperature has exceeded the threshold value set by parameter Hot .	<ul style="list-style-type: none"> Alarm EEP added to folder ALr Steady alarm icon (●) 	The temperature falls back below the value Hot .

Code	Description	Cause	Effects	Solutions
EEt	Max valve output alarm	The output valve is fully open (see parameter U02).	<ul style="list-style-type: none"> Alarm EEt added to folder ALr Steady alarm icon ((●)) 	<ul style="list-style-type: none"> Verify valve connection Verify overheating probe connection / operation.
EES	Saturation probe in error	<ul style="list-style-type: none"> Reading of values outside the operating interval Probe or corresponding wiring in short-circuit or open circuit 	<ul style="list-style-type: none"> EES shown Steady alarm icon ((●)) 	<ul style="list-style-type: none"> Verify the type of probe (rSP). Verify the probe wiring. Replace probe.
LEL	Low leak detection threshold	The value remains under the threshold ALL for a time period greater than AL1.	<ul style="list-style-type: none"> Alarm LEL added to folder ALr Steady alarm icon ((●)) 	The temperature rises back above the value ALL .
LEH	High leak detection threshold	The value remains over the threshold ALH for a time period greater than AL2.	<ul style="list-style-type: none"> Alarm LEH added to folder ALr Steady alarm icon ((●)) 	The temperature falls back below the value ALH .
PAn	Panic alarm (only present with KDX terminal)	Activation of suitably configured digital input (H1x = ±19 or i0x = ±19).	<ul style="list-style-type: none"> Alarm PAn added to folder ALr Steady alarm icon ((●)) Steady panic alarm icon ((!)) No effect on regulation 	Verify and remove the external cause that caused the alarm on the digital input.
ELi	Incorrect number of devices	The number of instruments detected within the Link ² network is different from the number set with L11 .	<ul style="list-style-type: none"> ELi appears Steady alarm icon ((●)) 	Align the number of devices in the Link ² network with the value of parameter L11 .

Note: All alarms are deactivated automatically when the cause is removed.

Probe alarms

Description

When one of the probes is outside the nominal operating range or if the probe is open or short-circuited, an alarm is generated if this condition persists for around 10 seconds.

For all probes, the error condition causes the following actions:

- alarm code appears on the display (see table)
- alarm icon comes on steadily and alarm relay activated (if present)

When the probe error condition ceases, regulation resumes as normal. During the probe error condition, the defrost interval count continues as normal.

Alarm acknowledgment

Codes **E1...E8**, **EL** and **Ei**, if simultaneous, are shown in the following sequence: E1 x 2 seconds, E2 x 2 seconds, E3 x 2 seconds, etc.

In alarm condition, press any key or use the menu function to acknowledge the relay configured as alarm (if present) while the alarm condition persists. The alarm icon will begin to flash.

The probe error alarm is not stored by the device.

Alarm codes

Code	Description
E1	Probe Pb1 in error
E2	Probe Pb2 in error
E3	Probe Pb3 in error
E4	Probe Pb4 in error
E5	Probe Pb5 in error
E6	Probe Pb6 (4...20 mA) in error
E7	Probe Pb7 (ratiometric) in error
E8	Probe Pb8 (4...20 mA via KDX) in error
EL	LINK ² probe in error / not working
Ei	VIRTUAL probe not working

Parameters

Parameter	Description
Ont	Compressor output on time if regulation probe in error
OfT	Compressor output off time if regulation probe in error

Minimum and maximum temperature alarm

Description

The alarms operate according to the temperature read by regulation probe 1/2. The accepted temperature interval limits are set using parameters **HA1/2** and **LA1/2**.

Note: High and low temperature alarms are excluded during a defrost. The triggering of these alarms does not have any effect on the regulation in progress.

Alarm acknowledgment

In alarm condition, press any key or use the menu function to acknowledge the relay configured as alarm (if present) while the alarm condition persists.

The alarm icon (🔔) will begin to flash.

The probe error alarm is not stored by the device.

Alarm codes

Code	Description
AH1	Probe 1 high temperature alarm
AL1	Probe 1 low temperature alarm
AH2	Probe 2 high temperature alarm
AL2	Probe 2 low temperature alarm

Absolute or relative temperature values

Depending on the value of parameter **Att**, the temperature is expressed as an absolute or relative value (differential in respect to the setpoint):

Att value	Label	Description
0	Ab	Absolute values. The HA1/2 and LA1/2 values must have a sign.
1	rE	Relative values. HA1/2 > 0 and LA1/2 < 0.

Alarm conditions

The maximum/minimum alarm is triggered when the temperature of probe 1/2 is:

- Maximum alarm: $\geq \text{HA1/2}$ if Att = AbS(0) and $\geq (\text{SP1/2} + \text{HA1/2})$ if Att = rEL(1)
- Minimum alarm: $\leq \text{LA1/2}$ if Att = AbS(0) and $\leq (\text{SP1/2} + \text{LA1/2})$ if Att = rEL(1)

If Att=AbS(0) set the values of **HA1/2** and **LA1/2** with a sign.

If Att=rEL(1) set **HA1/2** > 0 and **LA1/2** < 0.

When one of the above conditions arises, if there are no alarm exclusion times applied (see alarm exclusion parameters), the alarm icon (🔔) comes on and the relay configured as alarm (if present) is activated.

The alarm reset takes place when the temperature of probe 1/2 is:

- Reset after maximum alarm:
 $\leq (\text{HA1/2} - \text{AFd})$ if Att = AbS(0) and $\leq (\text{SP1/2} + \text{HA1/2} - \text{AFd})$ if Att = rEL(1)
- Reset after minimum alarm:
 $\geq (\text{LA1/2} + \text{AFd})$ if Att = AbS(0) and $\geq (\text{SP1/2} + \text{LA1/2} + \text{AFd})$ if Att = rEL(1)

Operating diagrams

Operation with Att=0 (absolute values)

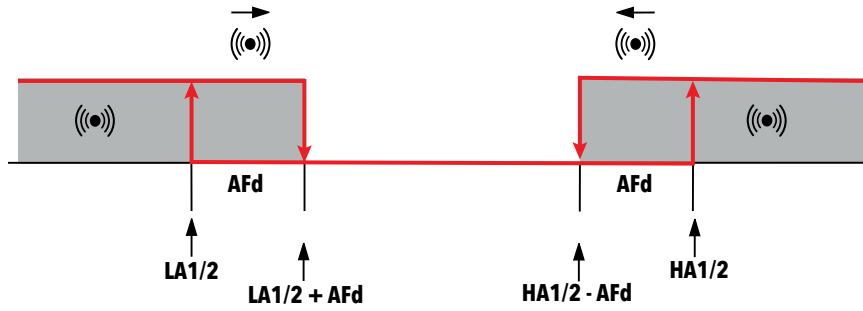

Operation with Att=1 (relative values)

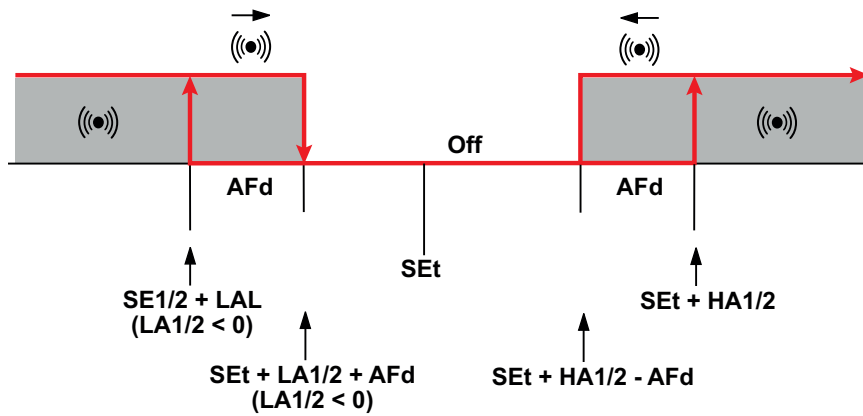

Parameters

Parameter	Description
Att	Expression mode for HAL and LAL values (absolute or relative)
AFd	Alarm activation differential
HA1	Probe 1 maximum alarm threshold
LA1	Probe 1 minimum alarm threshold
HA2	Probe 2 maximum alarm threshold
LA2	Probe 2 minimum alarm threshold
PAO	Temperature alarm exclusion time from startup
dAO	Exclusion time for temperature alarms after a defrost cycle
OAO	Exclusion time for temperature alarms after closing the door
tA1	Temperature alarm 1 signaling delay time
tA2	Temperature alarm 2 signaling delay time

Defrost ended due to timeout alarm

Description

The alarm regulator is activated with no delay if the defrost ends due to timeout, instead of the defrost end temperature being reached by the second probe.

The action consists of:

- the alarm icon (🔔) coming on steadily
- recording Label Ad2 in the alarms menu

Automatic deactivation takes place when the next defrost begins.

It is therefore possible to switch off the alarm icon using the normal acknowledgment procedure, while to remove the alarm indication you will need to wait for the next defrost cycle to start.

Alarm acknowledgment

In alarm condition, press any key or use the menu function to acknowledge the relay configured as alarm (if present) while the alarm condition persists. The alarm icon (🔔) will begin to flash.

Alarm codes

Code	Description
Ad2	Defrost alarm on Pb2

Parameters

Parameter	Description
dE1	Evaporator 1 defrost timeout
dE2	Evaporator 2 defrost timeout
dAt	Defrost ended due to timeout alarm signaling

External alarm

Description

When activating the digital input, the alarm regulator will be activated with the delay set by parameter dAd, and this alarm remains until the next time the digital input is deactivated.

The action consists of:

- the alarm icon coming on steadily
- recording Label EA in the alarms menu
- activating the relay configured as alarm (if enabled)
- deactivating regulation if parameter EAL requires it.

The alarm relay can be unlocked but the regulators remain inhibited until the digital input is deactivated.

Parameter **EAL** can assume the following values:

- **EAL** = 0: an external alarm does not inhibit any resources
- **EAL** = 1: an external alarm inhibits the compressor and defrost
- **EAL** = 2: an external alarm inhibits the compressor, defrost and the fans.

Alarm acknowledgment

In alarm condition, press any key or use the menu function to acknowledge the relay configured as alarm (if present) while the alarm condition persists. The alarm icon will begin to flash.

Alarm codes

Code	Description
EA	External alarm

Parameters

Parameter	Description
EAL	External alarm inhibits the regulators

Door open alarm

Description

The door switch alarm can be activated via a suitably configured digital input (**H1x**=± 8 or **i0x**=± 8).

When the digital input is activated (door opened), once delay **tdO** has elapsed, the door open alarm is indicated in the alarms folder and the alarm icon (☹) and alarm relay come on. The label **OPd** is shown.

The action consists of:

- the alarm icon (☹) coming on steadily
- recording Label **OPd** in the alarms menu
- activating the relay configured as alarm

As for the other alarms, the relay can be deactivated by pressing an acknowledgment key; the alarm icon will flash and label **OPd** remains in the menu until the door is closed.

If the door is opened, the regulator will work based on the value of parameter **dOd**.

It can assume the following values:

- **dOd** = 0: no resource inhibited
- **dOd** = 1: fans inhibited
- **dOd** = 2: compressor inhibited
- **dOd** = 3: fans and compressor inhibited

If the door open alarm inhibits the compressor, the latter can still be reactivated even if the door remains open by setting parameter **dCO**.

Alarm acknowledgment

In alarm condition, press any key or use the menu function to acknowledge the relay configured as alarm (if present) while the alarm condition persists. The alarm icon will begin to flash.

Alarm codes

Code	Description
OPd	Door open alarm

Parameters

Par.	Description
dOd	Digital input shuts off utilities.
dOA	Behavior forced from digital input (if PEA ≠ 0).
PEA	Selection of digital input with resource inhibiting/unlocking function.
dCO	Compressor activation delay from acknowledgment.
dFO	Fan activation/switch-off delay after consent (DI activation).
tdO	Door open alarm exclusion time

Parameters

Contents

This section includes the following topics:

Parametri utente RTX 600 <i>N</i>	157
Parametri installatore RTX 600 <i>N</i>	169

Parametri utente RTX 600 /V

PAR	Description	Range	UM
CP (Compressor)			
rP1	Sets the probe used by thermostat 1. <ul style="list-style-type: none"> • diS (0) = disabled • Pb1 (1) = probe Pb1 • Pb2 (2) = probe Pb2 • Pb3 (3) = probe Pb3 • Pb4 (4) = probe Pb4 • Pb5 (5) = probe Pb5 • Pbi (6) = virtual probe • LP (7) = remote probe • Pfi (8) = filtered virtual probe 	diS, Pb1...Pb5, Pbi, LP, Pfi	num
SP1	Thermostat 1 regulation setpoint.	LS1...HS1	°C/°F
dF1	Tripping differential for thermostat 1 (absolute or relative). Note: always a value other than 0.	-58.0...302	°C/°F
HS1	Maximum value that can be attributed to setpoint SP1. Note: The two sets are interdependent: HS1 cannot be less than LS1 and vice versa.	LS1...HdL	°C/°F
LS1	Minimum value that can be attributed to setpoint SP1. Note: The two sets are interdependent: LS1 cannot be greater than HS1 and vice versa.	LdL...HS1	°C/°F
Ont	Regulator switch-on time for faulty probe: <ul style="list-style-type: none"> • if Ont = 1 and Oft = 0 compressor always on • if Ont = 1 and Oft > 0 compressor in duty cycle 	0...250	min
Oft	Regulator switch-off time for faulty probe: <ul style="list-style-type: none"> • if Oft = 1 and Ont = 0 compressor always off • if Oft = 1 and Ont > 0 compressor in duty cycle 	0...250	min
OdO	Output activation delay time from switching on the device or after a power failure. 0 = not active.	0...250	min
POt	Pump down time. Sets the running time after evaporator valve closure.	0...250	s
dEF (Defrost)			
dP1	Sets the probe used by defrost 1 (only if rE ≠0). <ul style="list-style-type: none"> • diS (0) = disabled • Pb1 (1) = probe Pb1 • Pb2 (2) = probe Pb2 • Pb3 (3) = probe Pb3 • Pb4 (4) = probe Pb4 • Pb5 (5) = probe Pb5 • Pbi (6) = virtual probe • LP (7) = remote probe • Pfi (8) = filtered virtual probe 	diS, Pb1...Pb5, Pbi, LP, Pfi	num
dty	Type of defrost. <ul style="list-style-type: none"> • 0 = electric heater defrost • 1 = cycle inversion defrost • 2 = hot gas defrost for plug-in systems (with built-in compressor) • 3 = hot gas defrost for systems with remote group • 4 = modulated electric heater defrost (Smart Defrost). 	0...4	num

PAR	Description	Range	UM
dit	Time interval between the start of two subsequent defrost operations. 0 = function disabled (defrost NEVER takes place).	0...250	hours
dCt	Selects defrost interval count mode. <ul style="list-style-type: none"> 0 = defrost disabled 1 = hours of compressor operation (DIGIFROST® method); defrosting active ONLY with compressor on Note: the compressor run time is calculated independently of the evaporator probe (the calculation is active even if the evaporator probe is absent or not working). <ul style="list-style-type: none"> 2 = hours of device operation; counting is always active when the machine is on and starts at every power-on 3 = compressor stop. Each time the compressor stops, a defrosting cycle is performed in accordance with dtY 4 = RTC 5 = temperature. 	0...5	num
dE1	Defrost 1 timeout. Sets the maximum duration of defrost 1.	1...250	min
dS1	Defrost 1 end temperature (only if dP1 ≠diS)	-58.0...302	°C/°F
dSS	Defrost start temperature threshold (only if dCt =5).	-58.0...302	°C/°F
dPO	Determines whether, upon switching on, the device activates defrosting (providing that the temperature measured on the evaporator permits it). <ul style="list-style-type: none"> no (0) = no, do not defrost at switch-on yES (1) = yes, defrost at switch-on. 	no/yES	flag
dPH	Regular defrost start hour (only if dCt =4). <ul style="list-style-type: none"> 0...23 = start hour 24 = disabled. 	0...24	hours
dPn	Regular defrost start minutes (only if dCt =4).	0...59	min
dPd	Interval between one regular defrost and the next (only if dCt =4).	1...7	days
Fd1	1st weekend/holiday day (only if dCt =4). <ul style="list-style-type: none"> 0...6 = start day 7 = disabled. 	0...7	days
Fd2	2nd weekend/holiday day (only if dCt =4). <ul style="list-style-type: none"> 0...6 = start day 7 = disabled. 	0...7	days
PrH	Basin heater pre-activation time before defrost begins.	0...255	min
Fdn	Number of multiple defrosts during one weekday (only if dCt =4). 0 = disabled.	0...250	num
FFn	Number of multiple defrosts during one weekend/holiday day(only if dCt =4). 0 = disabled.	0...250	num
d1H	1st weekday defrost start hour (only if dCt =4). <ul style="list-style-type: none"> 0...23 = start hour 24 = disabled 	0...24	flag
d1n	1st weekday defrost start minutes (only if dCt =4).	0...59	num

PAR	Description	Range	UM
d2H	2nd weekday defrost start hour (only if dCt=4). <ul style="list-style-type: none"> d1H...23 = start hour 24 = disabled 	d1H...24	flag
d2n	2nd weekday defrost start minutes (only if dCt=4).	0...59	num
d3H	3rd weekday defrost start hour (only if dCt=4). <ul style="list-style-type: none"> d2H...23 = start hour 24 = disabled. 	d2H...24	flag
d3n	3rd weekday defrost start minutes (only if dCt=4).	0...59	num
d4H	4th weekday defrost start hour (only if dCt=4). <ul style="list-style-type: none"> d3H...23 = start hour 24 = disabled. 	d3H...24	flag
d4n	4th weekday defrost start minutes (only if dCt=4).	0...59	num
d5H	5th weekday defrost start hour (only if dCt=4). <ul style="list-style-type: none"> d4H...23 = start hour 24 = disabled 	d4H...24	flag
d5n	5th weekday defrost start minutes (only if dCt=4).	0...59	num
d6H	6th weekday defrost start hour (only if dCt=4). <ul style="list-style-type: none"> d5H...23 = start hour 24 = disabled 	d5H...24	flag
d6n	6th weekday defrost start minutes (only if dCt=4).	0...59	num
F1H	1st weekend/holiday defrost start hour (only if dCt=4). <ul style="list-style-type: none"> 0...23 = start hour 24 = disabled 	0...24	flag
F1n	1st weekend/holiday defrost start minutes (only if dCt=4).	0...59	num
F2H	2nd weekend/holiday defrost start hour (only if dCt=4). <ul style="list-style-type: none"> F1H...23 = start hour 24 = disabled 	F1H...24	flag
F2n	2nd weekend/holiday defrost start minutes (only if dCt=4).	0...59	num
F3H	3rd weekend/holiday defrost start hour (only if dCt=4). <ul style="list-style-type: none"> F2H...23 = start hour 24 = disabled 	F2H...24	flag
F3n	3rd weekend/holiday defrost start minutes (only if dCt=4).	0...59	num
F4H	4th weekend/holiday defrost start hour (only if dCt=4). <ul style="list-style-type: none"> F3H...23 = start hour 24 = disabled 	F3H...24	flag
F4n	4th weekend/holiday defrost start minutes (only if dCt=4).	0...59	num
F5H	5th weekend/holiday defrost start hour (only if dCt=4). <ul style="list-style-type: none"> F4H...23 = start hour 24 = disabled 	F4H...24	flag

PAR	Description	Range	UM
F5n	5th weekend/holiday defrost start minutes (only if dCt=4).	0...59	num
F6H	6th weekend/holiday defrost start hour (only if dCt=4). <ul style="list-style-type: none"> • F5H...23 = start hour • 24 = disabled 	F5H...24	flag
F6n	6th weekend/holiday defrost start minutes (only if dCt=4).	0...59	num
Fan			
FP1	Sets the probe used by the evaporator fans during normal operation. <ul style="list-style-type: none"> • diS (0) = disabled • Pb1 (1) = probe Pb1 • Pb2 (2) = probe Pb2 • Pb3 (3) = probe Pb3 • Pb4 (4) = probe Pb4 • Pb5 (5) = probe Pb5 • Pbi (6) = virtual probe • LP (7) = remote probe • PFi (8) = filtered virtual probe. 	diS, Pb1...Pb5, Pbi, LP, PFi	num
FSt	Fan disabling temperature. If the value read is greater than FSt , the fans will be stopped. The value is positive or negative (only if FP1≠diS).	-58.0...302	°C/°F
FAd	Evaporator fan activation differential (only if FP1≠dis).	1.0...25.0	°C/°F
dt	Dripping time.	0...250	min
dFd	Evaporator fan operating mode during a defrost. <ul style="list-style-type: none"> • OFF(0) = Fans off • On(1) = Fans on 	OFF/On	flag

PAR	Description						Range	UM	
FCO	Evaporator fan operating mode.						0...4	num	
	Pb2	H42	FCo	day		night			
				Cn	Cf	Cn			Cf
	ok	y	0	T	Off	T			Off
			1	T	T	T			T
			2	T	T	T			T
			3	T	DCd	T			DCn
	no	n	4	T	DCd	T			DCn
			0	On	Off	On			Off
			1	On	On	On			On
			2	DCd	DCd	DCn			DCn
	ko	y	3	On	DCd	On			DCn
			4	On	DCd	On			DCn
			0	DCd	Off	DCn			Off
			1	On	Off	On			Off
			2	DCd	DCd	DCn			DCn
			3	DCd	DCd	DCn			DCn
		4	DCd	DCd	DCn	DCn			
Headings legend: <ul style="list-style-type: none"> • Pb2 = probe Pb2 status • day = day mode • night = night mode • Cn = compressor on • Cf = compressor off. Status legend: <ul style="list-style-type: none"> • ok = probe present • ko = probe in error E2 • no = no probe • T = thermostat controlled fans • On = fans on • Off = fans off • DCd = day duty cycle • DCn = night duty cycle. 									
FOn	Fan on time for day duty cycle. Applies when Duty cycle mode is active (see FCO).						0...250	min	
FOF	Fan off time for day duty cycle. Applies when Duty cycle mode is active (see FCO).						0...250	min	
Fnn	Fan on time for night duty cycle. Applies when Duty cycle mode is active (see FCO).						0...250	min	
FnF	Fan off time for night duty cycle. Applies when Duty cycle mode is active (see FCO).						0...250	min	
FE (Modulated Fans)									
FES	"Modulated fans" regulator inhibiting temperature.						-58.0...302	°C/°F	
FEd	Tripping differential for "modulated fans" regulator (absolute or relative).						0.1...50.0	°C/°F	
FEu	Threshold value (Cut-OFF) on "modulated fans" regulator.						0.0...25.0	°C/°F	
FEC	Activation differential for the threshold value (Cut-OFF) on "modulated fans" regulator.						0.1...25.0	°C/°F	
AL (Alarms)									

PAR	Description	Range	UM
rA1	Sets probe 1 used for temperature alarms. <ul style="list-style-type: none"> • diS (0) = disabled • Pb1 (1) = probe Pb1 • Pb2 (2) = probe Pb2 • Pb3 (3) = probe Pb3 • Pb4 (4) = probe Pb4 • Pb5 (5) = probe Pb5 • Pbi (6) = virtual probe • PFI (7) = filtered virtual probe 	diS, Pb1...Pb5, Pbi, LP, PFI	num
Att	Sets the absolute or relative value for parameters HA1/HA2 and LA1/LA2 . <ul style="list-style-type: none"> • AbS (0) = absolute value • rEL (1) = relative value 	AbS/rEL	flag
AFd	Alarm activation differential.	0.1...25.0	°C/°F
HA1	Probe 1 maximum alarm (only if rA1 ≠diS). Temperature value (Att function) which, when exceeded, will lead to the activation of alarm signaling.	LA1...302	°C/°F
LA1	Probe 1 minimum alarm (only if rA1 ≠diS). Temperature value (Att function) which, when exceeded, will lead to the activation of alarm signaling.	-58.0...HA1	°C/°F
PAO	Alarm exclusion time when switching on the device, after a power failure. Refers only to high and low temperature alarms.	0...10	hours
dAO	Temperature alarm exclusion time after defrosting.	0...250	min
tA1	Temperature alarm 1 signaling delay (only if rA1 ≠diS). Refers only to high and low temperature alarms LA1 and HA1 .	0...250	min
dAt	Defrost ended due to timeout alarm indication. <ul style="list-style-type: none"> • no(0) = alarm not activated • yES(1) = alarm activated 	no/yES	flag
ALL	Leak alarm detector minimum alarm threshold.	0.0...ALH	°C/°F
ALH	Leak alarm detector maximum alarm threshold.	ALL...100	°C/°F
Lin (Link²)			
L00	Sets which probe to share via Link ² : <ul style="list-style-type: none"> • diS (0) = disabled • Pb1 (1) = probe Pb1 • Pb2 (2) = probe Pb2 • Pb3 (3) = probe Pb3 • Pb4 (4) = probe Pb4 • Pb5 (5) = probe Pb5 • Pbi (6) = virtual probe • PFI (7) = filtered virtual probe 	diS, Pb1...Pb5, Pbi, LP, PFI	num
L01	Shares the displayed value with the Link 2 network. <ul style="list-style-type: none"> • 0 = prevents sending the displayed value from the device to the Link2 network • 1 = enables sending the displayed value from the device to the Link2 network² • 2 = displays the value of the device with setting L01 = 1. 	0/1/2	num
L02	Sends the Setpoint value to the Link 2 network when it is changed. <ul style="list-style-type: none"> • no (0) = no • yES (1) = yes. 	no/yES	flag

PAR	Description	Range	UM
L03	Enables the sending of the defrost request to the Link 2 network. <ul style="list-style-type: none"> • 0 = send defrost request disabled • 1 = master device for sending simultaneous defrost request • 2 = master device for sending sequential defrost request 	0/1/2	num
L04	Defrost end method. <ul style="list-style-type: none"> • ind (0) = independent • dEP (1) = dependent. Waits for all controllers to have finished defrosting. 	ind/dEP	flag
L05	Enable Stand-by command synchronization <ul style="list-style-type: none"> • no (0) = no • yES (1) = yes 	no/yES	flag
L06	Enable light command synchronization <ul style="list-style-type: none"> • no (0) = no • yES (1) = yes 	no/yES	flag
L07	Enable Energy Saving command synchronization <ul style="list-style-type: none"> • no (0) = no • yES (1) = yes 	no/yES	flag
L08	Enable AUX command synchronization <ul style="list-style-type: none"> • no (0) = no • yES (1) = yes 	no/yES	flag
L09	Enables sharing of the saturation probe (pressure). <ul style="list-style-type: none"> • no (0) = no • yES (1) = yes 	no/yES	flag
L10	Sets the wait timeout for the end of dependent defrosts.	0...250	min
L11	Sets the number of devices connected to Link ² . If the number of devices differs from the set value, a Link 2 alarm will be activated (ELI).	0..8	num
L12	Set how to share alarms <ul style="list-style-type: none"> • 0 = function disabled • 1 = alarm relay master • 2 = alarm relay slave 	0/1/2	num
EnS (Energy Saving)			
ESt	Type of event activated via RTC. <ul style="list-style-type: none"> • 0 = disabled • 1 = Energy Saving • 2 = Energy Saving + Light off • 3 = Energy Saving + Light off + AUX output active • 4 = Device off • 5 = Energy saving + Terminal buzzer silencing • 6 = Energy saving + Light off + Terminal buzzer silencing • 7 = Energy Saving + Light off + AUX output active + Terminal buzzer silencing • 8 = Device off + Terminal buzzer silencing 	0...8	num
ESF	Activates night mode (energy saving) for the fans. <ul style="list-style-type: none"> • no (0) = disabled • yES (1) = enabled if energy saving mode is active (only if ES_t≠0 and ES_t≠4). 	no/yES	flag
OS1	Offset on setpoint 1 (SP1) in energy saving mode.	-50.0...50.0	°C/°F

PAR	Description	Range	UM
dn1	Differential on setpoint 1 (SP1) in energy saving mode.	-58.0...302	°C/°F
EdH	Weekday Energy Saving start hour. <ul style="list-style-type: none"> • 0...23 = start hour • 24 = disabled 	0...24	hours
Edn	Weekday Energy Saving start minutes.	0...59	min
Edd	Weekday Energy Saving duration.	1...72	hours
EFH	Weekend/holiday Energy Saving start hour. <ul style="list-style-type: none"> • 0...23 = start hour • 24 = disabled 	0...24	hours
EFn	Weekend/holiday Energy Saving start minutes.	0...59	min
EFd	Weekend/holiday Energy Saving duration.	1...72	hours
FrH (Anti-condensation heaters - Frame Heater)			
FH	Sets which probes use the anti-condensation heaters (FH). <ul style="list-style-type: none"> • diS (0) = disabled • dc (1) = duty cycle • Pb1 (2) = probe Pb1 • Pb2 (3) = probe Pb2 • Pb3 (4) = probe Pb3 • Pb4 (5) = probe Pb4 • Pb5 (6) = probe Pb5 • Pbi (7) = virtual probe • PFi (8) = filtered virtual probe • PbC (9) = KDX terminal probe 	diS, dc, Pb1...Pb5, Pbi, PFi, PbC	num
FHt	Anti-condensation heater operating period duration (FH), only used if the OC output is used with SSR relay.	1...250	s*10
FH0	Sets the Setpoint corresponding to the anti-condensation heaters (only if FH ≠dis and FH ≠dc).	-58.0...302	°C/°F
FH1	Sets the Offset corresponding to the anti-condensation heaters (only if FH ≠dis and FH ≠dc).	0.0...25.0	°C/°F
FH2	Sets the Band corresponding to the anti-condensation heaters (only if FH ≠dis and FH ≠dc).	-58.0...302	°C/°F
FH3	Sets the minimum percentage for the anti-condensation heaters (only if FH ≠dis and FH ≠dc).	0...100	%
FH4	Sets the maximum percentage for the day Duty cycle.	0...100	%
FH5	Sets the maximum percentage for the night Duty cycle.	0...100	%
FH6	Sets the anti-condensation heater percentage during defrost.	0...100	%
Add (Communication)			
Adr	Modbus protocol controller address.	1...250	flag
Pty	Modbus parity bit. <ul style="list-style-type: none"> • n(0) = none • E(1) = even • o(2) = odd. 	n/E/o	num
diS (Display)			
LOC	LOCK. Setpoint change lock. It is still possible to enter parameter programming and change them, including the status of this parameter in order to unlock the terminal. <ul style="list-style-type: none"> • no (0) = no • yES (1) = yes 	no/yES	flag

PAR	Description	Range	UM
ndt	Display with decimal point. <ul style="list-style-type: none"> no (0) = no (integers only) yES (1) = yes (display with decimal). 	no/yES	flag
CA1	Calibration of probe Pb1 (only if H41 ≠Pro). Positive or negative temperature values that are added to those read by Pb1. This sum is used for the displayed temperature as well as for the regulation.	-30.0...30.0	°C/°F
CA2	Calibration of probe Pb2 (only if H42 ≠Pro). Positive or negative temperature values that are added to those read by Pb2. This sum is used for the displayed temperature as well as for the regulation.	-30.0...30.0	°C/°F
CA3	Calibration of probe Pb3 (only if H43 ≠Pro). Positive or negative temperature values that are added to those read by Pb3. This sum is used for the displayed temperature as well as for the regulation.	-30.0...30.0	°C/°F
CA4	Calibration of probe Pb4 (only if H44 ≠Pro). Positive or negative temperature values that are added to those read by Pb4. This sum is used for the displayed temperature as well as for the regulation.	-30.0...30.0	°C/°F
CA5	Calibration of probe Pb5 (only if H45 ≠Pro). Positive or negative temperature values that are added to those read by Pb5. This sum is used for the displayed temperature as well as for the regulation.	-30.0...30.0	°C/°F
CA6	Calibration of pressure transducer Pb6 (4...20 mA) (only if H46 =Pro). Positive or negative temperature values that are added to those read by pressure transducer Pb6 (4...20 mA). This sum is used for the displayed temperature as well as for the regulation.	-30.0...30.0	°C/°F
CA7	Calibration of radiometric transducer Pb7 (only if H47 =Pro). Positive or negative temperature values that are added to those read by radiometric transducer Pb7. This sum is used for the displayed temperature as well as for the regulation.	-30.0...30.0	°C/°F
LdL	Minimum value that can be displayed by the device.	-58.0...HdL	°C/°F
HdL	Maximum value that can be displayed by the device.	LdL...302	°C/°F
ddL	Display mode during defrosting. <ul style="list-style-type: none"> 0 = display the temperature read by the probe or the setpoint (see ddd) 1 = locks the reading at the temperature value read by the probe at the start of defrost until reaching SEt (or until the expiration of Ldd) 2 = displays label dEF during defrost until reaching SEt (or until the expiration of Ldd). 	0/1/2	num
Ldd	Display unlocking timeout value.	0...250	min
ddd	Sets the value to show on the display. <ul style="list-style-type: none"> SP1 (0) = setpoint SP1 Pb1 (1) = probe Pb1 Pb2 (2) = probe Pb2 Pb3 (3) = probe Pb3 Pb4 (4) = probe Pb4 Pb5 (5) = probe Pb5 Pbi (6) = virtual probe LP (7) = remote probe Pfi (8) = filtered virtual probe 	SP1, Pb1...Pb5, Pbi, LP, Pfi	num

PAR	Description	Range	UM
CnF (Configuration)			
trA	<p>Selects the model of ratiometric transducer used.</p> <ul style="list-style-type: none"> • USE (0) = Generic Probe Set by customer • rA1 (1) = EWPA 010 R 0/5 V 0/10 BAR FEMALE • rA2 (2) = EWPA 030 R 0/5 V 0/30 BAR FEMALE • rA3 (3) = EWPA 050 R 0/5 V 0/50 BAR FEMALE • rA4 (4) = AKS 32R -1 ...6 BAR • rA5 (5) = AKS 32R -1 ...12 BAR • rA6 (6) = AKS 32R -1 ... 20 BAR • rA7 (7) = AKS 32R -1 ... 34 BAR • rA8 (8) = Reserved. <p>Note: The upper and lower limits of probes rA1... rA8 are pre-set (and cannot be changed), while if you select USE you will need to set them via parameters H05 and H06.</p>	USE, rA1...rA8	num
H00	<p>Select probe type used (Pb1...Pb5).</p> <ul style="list-style-type: none"> • ntc (0) = NTC • Ptc (1) = PTC • Pt1 (2) = Pt1000 	ntc, PTC, Pt1	num
H08	<p>Stand-by operating mode</p> <ul style="list-style-type: none"> • 0 = display off; the regulators are active and the device signals possible alarms by reactivating the display • 1 = display off; the regulators and the alarms are blocked • 2 = the display shows the label "OFF"; the regulators and alarms are inhibited. 	0/1/2	num
H16	Configuration of digital input 6/polarity (Pb6) (only if H46=di). Same as H11 .	-19...+19	num
H18	Digital input 8/polarity (DI) configuration. Same as H11 .	-19...+19	num
d16	Digital input 6 activation delay (Pb6) (only if H46=di).	0...255	min
d18	Digital input 8 (DI) activation delay.	0...255	min
H24	Digital output 4 configuration (OUT 4). Same as H21 .	0...19	num
H27	Configuration of digital output 7 (Open Collector). Same as H21 .	0...19	num
H33	Configuration of the ESC key. Same as H31 .	0...9	num
H60	<p>Display selected application.</p> <ul style="list-style-type: none"> • 0 = disabled • 1 = AP1 • 2 = AP2 • 3 = AP3 • 4 = AP4 • 5 = AP5 • 6 = AP6 • 7 = AP7 • 8 = AP8 	0...8	num
EE0 (Electronic Expansion Valve)			

PAR	Description	Range	UM
rSP	Sets the saturation probe to use. <ul style="list-style-type: none"> • diS (0) = disabled • Pb6 (1) = pressure transducer 4...20 mA • Pb7 (2) = ratiometric transducer • LSP (3) = remote probe (shared within the Link2 network) • rP (4) = remote probe (from supervisor). 	diS, Pb6, Pb7, LSP, rP	num
rSS	Sets the overheating probe to use. <ul style="list-style-type: none"> • diS (0) = disabled • Pb1 (1) = probe Pb1 • Pb2 (2) = probe Pb2 • Pb3 (3) = probe Pb3 • Pb4 (4) = probe Pb4 • Pb5 (5) = probe Pb5 	diS, Pb1...Pb5	num
EPd	Saturation value display mode. <ul style="list-style-type: none"> • t (0) = temperature • P (1) = pressure 	t/P	flag
Ert	Selects the type of refrigerant used. <ul style="list-style-type: none"> • 404 (0) = R404A • r22 (1) = R22 • 410 (2) = R410A • 134 (3) = R134a • 744 (4) = R744 (CO2) • 507 (5) = R507A • 717 (6) = R717 (NH3) • 290 (7) = reserved • 407 (8) = R407A • 448 (9) = R448A • 449 (10) = R449A • 450 (11) = R450 • 513 (12) = R513A • PAr_1 (13) = customizable 1 • PAr_2 (14) = customizable 2 • PAr_3 (15) = customizable 3 • PAr_4 (16) = customizable 4 • PAr_5 (17) = customizable 5 • PAr_6 (18) = customizable 6 <p>Note: For customizations regarding the type of refrigerant used, please contact Eliwell.</p>	404, r22, 410 134, 744, 507, 717, 290, 407, 448, 449 450, 513, PAr_1...PAr_6	num
U06	Minimum useful valve opening percentage.	0...100	%
OLt	Minimum overheating threshold.	0.0...999.9	°C/°F
FnC (Functions) - Note : If the device is switched off the function labels will revert to default status (inactive). To change their status, press the "set" key			
dEF	Manual defrost activation. <ul style="list-style-type: none"> • Function active: dEF label and flashing icon • Function inactive: dEF label • Indication: Defrost icon flashing 	/	/
AUX	Manual auxiliary output activation. <ul style="list-style-type: none"> • Function active: Aon label • Function inactive: AoF label • Indication: AUX icon steadily lit 	/	/
Stand-by	Manual stand-by activation. <ul style="list-style-type: none"> • Function active: ON label • Function inactive: OFF label • Indication: Stand-by LED lit steadily (only KDWPlus) 	/	/
OiL (Compressor oil heater)			
OSP	Sets the regulation setpoint used by the compressor oil heater.	OLS...OHS	°C/°F
OHd	Sets the regulation differential used by the compressor oil heater.	0.1...25.0	°C/°F

Note: the "User" menu parameters also include **PA2**, which allows access to the "Installer" menu.

Note: for the full list of parameters, see the section "**Installer parameters**".

Parametri installatore RTX 600 /V

PAR	Description	Range	UM	Value	AP1	AP2	AP3	AP4	AP5	AP6	AP7	AP8
CP (Compressor)												
rE	Sets the type of regulation to perform. <ul style="list-style-type: none"> 0: single thermostat 1: dual thermostat in series 2: dual thermostat in parallel 3: reserved 4: two independent regulators 5: continuous modulation, single thermostat 6: continuous modulation, dual thermostat in series. 	0...6	num	0	0	0	0	0	0	0	0	0
rP1	Sets the probe used by thermostat 1. <ul style="list-style-type: none"> diS (0) = disabled Pb1 (1) = probe Pb1 Pb2 (2) = probe Pb2 Pb3 (3) = probe Pb3 Pb4 (4) = probe Pb4 Pb5 (5) = probe Pb5 Pbi (6) = virtual probe LP (7) = remote probe PFI (8) = filtered virtual probe 	diS, Pb1...Pb5, Pbi, LP, PFI	num	Pb1	Pb1	Pb1	Pb1	Pb1	Pb1	Pb1	Pb1	Pb1
rP2	Sets the probe used by thermostat 2 (only if rE ≠0). <ul style="list-style-type: none"> diS (0) = disabled Pb1 (1) = probe Pb1 Pb2 (2) = probe Pb2 Pb3 (3) = probe Pb3 Pb4 (4) = probe Pb4 Pb5 (5) = probe Pb5 Pbi (6) = virtual probe LP (7) = remote probe PFI (8) = filtered virtual probe PbC (9) = KDX terminal probe 	diS, Pb1...Pb5, Pbi, LP, PFI, PbC	num	diS	diS	diS	diS	diS	diS	diS	diS	Pb2
SP1	Thermostat 1 regulation setpoint.	LS1...HS1	°C/°F	0.0	0.0	3.0	-18.0	0.0	3.0	-18.0	-18.0	-18.0
dF1	Tripping differential for thermostat 1 (absolute or relative). Note : always a value other than 0.	-58.0...302	°C/°F	2.0	2.0	2.0	2.0	2.0	2.0	2.0	2.0	2.0
SP2	Thermostat 2 regulation setpoint (only if rE ≠0).	LS2...HS2	°C/°F	0.0	0.0	0.0	0.0	0.0	0.0	0.0	0.0	-18.0
dF2	Tripping differential for thermostat 2 (absolute or relative) (only if rE ≠0). Note : always a value other than 0.	-58.0...302	°C/°F	0.0	0.0	0.0	0.0	0.0	0.0	0.0	0.0	0.0
Stt	Management mode for differentials dF1 and dF2 . <ul style="list-style-type: none"> AbS (0) = absolute value rEL (1) = relative value 	AbS/rEL	flag	rEL	rEL	rEL	rEL	rEL	rEL	rEL	rEL	rEL
HS1	Maximum value that can be attributed to setpoint SP1. Note : The two sets are interdependent: HS1 cannot be less than LS1 and vice versa.	LS1...HdL	°C/°F	20.0	20.0	20.0	20.0	20.0	20.0	20.0	20.0	20.0
LS1	Minimum value that can be attributed to setpoint SP1. Note : The two sets are interdependent: LS1 cannot be greater than HS1 and vice versa.	LdL...HS1	°C/°F	-35.0	-35.0	-35.0	-35.0	-35.0	-35.0	-35.0	-35.0	-35.0
HS2	Maximum value that can be attributed to setpoint SP2 (only if rE ≠0). Note : The two sets are interdependent: HS2 cannot be less than LS2 and vice versa.	LS2...HdL	°C/°F	0.0	0.0	0.0	0.0	0.0	0.0	0.0	0.0	0.0

PAR	Description	Range	UM	Value	AP1	AP2	AP3	AP4	AP5	AP6	AP7	AP8
LS2	Minimum value that can be attributed to setpoint SP2 (only if rE ≠0). Note: The two sets are interdependent: LS2 cannot be greater than HS2 and vice versa.	LdL...HS2	°C/°F	0.0	0.0	0.0	0.0	0.0	0.0	0.0	0.0	0.0
HC1	Selects thermostat 1 regulation mode. <ul style="list-style-type: none"> C(0) = Cool H(1) = Heat 	C/H	flag	C	C	C	C	C	C	C	C	C
HC2	Selects thermostat 2 regulation mode (only if rE ≠0). Same as HC1 .	C/H	flag	C	C	C	C	C	C	C	C	C
Cit	Minimum compressor activation time. If Cit =0 it is not active.	0...250	min	0	0	0	0	0	0	0	0	0
CAt	Maximum compressor activation time. If CAt =0 it is not active.	0...250	min	0	0	0	0	0	0	0	0	0
Ont	Regulator switch-on time for faulty probe: <ul style="list-style-type: none"> if Ont = 1 and OFt = 0 compressor always on if Ont = 1 and OFt > 0 compressor in duty cycle 	0...250	min	3	3	3	3	3	3	3	3	3
OFt	Regulator switch-off time for faulty probe: <ul style="list-style-type: none"> if OFt = 1 and Ont = 0 compressor always off if OFt = 1 and Ont > 0 compressor in duty cycle 	0...250	min	3	3	3	3	3	3	3	3	3
dOn	Compressor output activation delay time from call.	0...250	s	0	0	0	0	0	0	0	0	0
dOF	Compressor output activation delay time from the previous switch-off.	0...250	min	0	0	0	0	0	0	0	0	0
dbi	Delay time between two consecutive compressor switch-ons.	0...250	min	0	0	0	0	0	0	0	0	0
OdO	Output activation delay time from switching on the device or after a power failure. 0 = not active.	0...250	min	0	0	0	0	0	0	0	0	0
CFP	Condenser fan pre-ventilation time in Heat/Cool.	0...255	s	0	0	0	0	0	0	0	0	0
CFd	Condenser fan operating mode during a defrost. <ul style="list-style-type: none"> OFF = fans off On = fans on 	OFF/On	flag	OFF	OFF	OFF	OFF	OFF	OFF	OFF	OFF	OFF
OF1	Represents the value (Offset) which will be added to or subtracted from SP1 in the presence of remote commands. <ul style="list-style-type: none"> nOS = Activate setpoint offset forcing (SEt = SP1+OF1) oOS = Deactivate setpoint offset forcing (SEt = SP1). 	-50.0...50.0	°C/°F	0	0	0	0	0	0	0	0	0
POt	Pump down time. Sets the running time after evaporator valve closure.	0...250	s	0	0	0	0	0	0	0	0	0
SS1	Compressor soft start: advance hot gas valve opening. Sets the delay time between hot gas valve opening and compressor startup.	0...250	s	0	0	0	0	0	0	0	0	0
SS2	Compressor soft start: hot gas valve closure delay. Sets the delay time between compressor startup and hot gas valve closure.	0...250	s	0	0	0	0	0	0	0	0	0
dEF (Defrost)												

PAR	Description	Range	UM	Value	AP1	AP2	AP3	AP4	AP5	AP6	AP7	AP8
dP1	Sets the probe used by defrost 1 (only if rE ≠0). <ul style="list-style-type: none"> diS (0) = disabled Pb1 (1) = probe Pb1 Pb2 (2) = probe Pb2 Pb3 (3) = probe Pb3 Pb4 (4) = probe Pb4 Pb5 (5) = probe Pb5 Pbi (6) = virtual probe LP (7) = remote probe PFI (8) = filtered virtual probe 	diS, Pb1...Pb5, Pbi, LP, PFI	num	Pb2	Pb2	Pb2	Pb2	Pb2	Pb2	Pb2	Pb2	Pb3
dP2	Sets the probe used by defrost 2. Same as dP1 .	diS, Pb1...Pb5, Pbi, LP, PFI	num	diS	diS	diS	diS	diS	diS	diS	diS	diS
dtY	Type of defrost. <ul style="list-style-type: none"> 0 = electric heater defrost 1 = cycle inversion defrost 2 = hot gas defrost for plug-in systems (with built-in compressor) 3 = hot gas defrost for systems with remote group 4 = modulated electric heater defrost (Smart Defrost). 	0...4	num	0	0	0	0	0	0	0	0	0
dFt	Defrost activation mode using two probes. <ul style="list-style-type: none"> 0 = activation only linked to probe 1 1 = activation on a call from at least one of the two probes 2 = activation on a call from both probes 	0/1/2	num	0	0	0	0	0	0	0	0	0
dit	Time interval between the start of two subsequent defrost operations. 0 = function disabled (defrost NEVER takes place).	0...250	hours	24	24	24	24	24	24	24	24	24
dt1	Unit of measure for defrost interval (dit). <ul style="list-style-type: none"> 0 = hours 1 = minutes 2 = seconds 	0/1/2	num	0	0	0	0	0	0	0	0	0
dt2	Unit of measure for defrost duration (dE1/dE2) (only if dFt ≠0). <ul style="list-style-type: none"> 0 = hours 1 = minutes 2 = seconds 	0/1/2	num	1	1	1	1	1	1	1	1	1
dCt	Selects defrost interval count mode. <ul style="list-style-type: none"> 0 = defrost disabled 1 = hours of compressor operation (DIGIFROST® method); defrosting active ONLY with compressor on <p>Note: the compressor run time is calculated independently of the evaporator probe (the calculation is active even if the evaporator probe is absent or not working).</p> <ul style="list-style-type: none"> 2 = hours of device operation; counting is always active when the machine is on and starts at every power-on 3 = compressor stop. Each time the compressor stops, a defrosting cycle is performed in accordance with dtY 4 = RTC 5 = temperature. 	0...5	num	4	4	4	4	4	4	4	4	4
dOH	Defrost cycle activation delay from the call	0...250	min	0	0	0	0	0	0	0	0	0
dE1	Defrost 1 timeout. Sets the maximum duration of defrost 1.	1...250	min	30	30	30	30	30	30	30	30	30
dE2	Defrost 2 timeout (only if dFt ≠0). Sets the maximum duration of defrost 2.	1...250	min	30	30	30	30	30	30	30	30	30

PAR	Description	Range	UM	Value	AP1	AP2	AP3	AP4	AP5	AP6	AP7	AP8
dS1	Defrost 1 end temperature (only if dP1≠diS)	-58.0...302	°C/°F	7.0	7.0	7.0	7.0	7.0	7.0	7.0	7.0	7.0
dS2	Defrost 2 end temperature (only if dP2≠diS)	-58.0...302	°C/°F	7.0	7.0	7.0	7.0	7.0	7.0	7.0	7.0	7.0
dSS	Defrost start temperature threshold (only if dCt=5).	-58.0...302	°C/°F	-5.0	-5.0	-5.0	-5.0	-5.0	-5.0	-5.0	-5.0	-5.0
dPO	Determines whether, upon switching on, the device activates defrosting (providing that the temperature measured on the evaporator permits it). <ul style="list-style-type: none"> no (0) = no, do not defrost at switch-on yES (1) = yes, defrost at switch-on. 	no/yES	flag	no	no	no	no	no	no	no	no	no
tCd	Minimum period of time with the compressor ON or OFF before defrost is activated.	-60...60	min	0	0	0	0	0	0	0	0	0
ndE	Minimum defrost duration. Note: if dtY=0, dtY=1 or dtY=4, set ndE=0.	0...250	min	0	0	0	0	0	0	0	0	0
PdC	Hot gas extraction time at the end of the defrost.	0...250	min	0	0	0	0	0	0	0	0	0
tPd	Minimum pump down time before defrost is activated	0...255	min	0	0	0	0	0	0	0	0	0
dPH	Regular defrost start hour (only if dCt=4). <ul style="list-style-type: none"> 0...23 = start hour 24 = disabled. 	0...24	hours	24	24	24	24	24	24	24	24	24
dPn	Regular defrost start minutes (only if dCt=4).	0...59	min	0	0	0	0	0	0	0	0	0
dPd	Interval between one regular defrost and the next (only if dCt=4).	1...7	days	1	1	1	1	1	1	1	1	1
Fd1	1st weekend/holiday day (only if dCt=4). <ul style="list-style-type: none"> 0...6 = start day 7 = disabled. 	0...7	days	7	7	7	7	7	7	7	7	7
Fd2	2nd weekend/holiday day (only if dCt=4). <ul style="list-style-type: none"> 0...6 = start day 7 = disabled. 	0...7	days	7	7	7	7	7	7	7	7	7
Edt	Sets whether you want to enter a duration and defrost end temperature for each event (only if dCt=4). <ul style="list-style-type: none"> no (0) = values all the same yES (1) = custom values for each event. 	no/yES	flag	no	no	no	no	no	no	no	no	no
PrH	Basin heater pre-activation time before defrost begins.	0...255	min	0	0	0	0	0	0	0	0	0
Fdn	Number of multiple defrosts during one weekday (only if dCt=4). 0 = disabled.	0...250	num	0	0	0	0	0	0	0	0	0
FFn	Number of multiple defrosts during one weekend/holiday day(only if dCt=4). 0 = disabled.	0...250	num	0	0	0	0	0	0	0	0	0
d1H	1st weekday defrost start hour (only if dCt=4). <ul style="list-style-type: none"> 0...23 = start hour 24 = disabled 	0...24	flag	0	0	0	0	0	0	0	0	0
d1n	1st weekday defrost start minutes (only if dCt=4).	0...59	num	0	0	0	0	0	0	0	0	0
d1t	1st weekday defrost duration (only if dCt=4).	0...250	num	0	0	0	0	0	0	0	0	0
d1S	1st weekday defrost end temperature (only if dCt=4).	-58.0...302	°C/°F	0.0	0.0	0.0	0.0	0.0	0.0	0.0	0.0	0.0
d2H	2nd weekday defrost start hour (only if dCt=4). <ul style="list-style-type: none"> d1H...23 = start hour 24 = disabled 	d1H...24	flag	6	6	6	6	6	6	6	6	6
d2n	2nd weekday defrost start minutes (only if dCt=4).	0...59	num	0	0	0	0	0	0	0	0	0

PAR	Description	Range	UM	Value	AP1	AP2	AP3	AP4	AP5	AP6	AP7	AP8
d2t	2nd weekday defrost duration (only if dCt=4).	0...250	num	0	0	0	0	0	0	0	0	0
d2S	2nd weekday defrost end temperature (only if dCt=4).	-58.0...302	°C/°F	0.0	0.0	0.0	0.0	0.0	0.0	0.0	0.0	0.0
d3H	3rd weekday defrost start hour (only if dCt=4). • d2H...23 = start hour • 24 = disabled.	d2H...24	flag	12	12	12	12	12	12	12	12	12
d3n	3rd weekday defrost start minutes (only if dCt=4).	0...59	num	0	0	0	0	0	0	0	0	0
d3t	3rd weekday defrost duration (only if dCt=4).	0...250	num	0	0	0	0	0	0	0	0	0
d3S	3rd weekday defrost end temperature (only if dCt=4).	-58.0...302	°C/°F	0.0	0.0	0.0	0.0	0.0	0.0	0.0	0.0	0.0
d4H	4th weekday defrost start hour (only if dCt=4). • d3H...23 = start hour • 24 = disabled.	d3H...24	flag	18	18	18	18	18	18	18	18	18
d4n	4th weekday defrost start minutes (only if dCt=4).	0...59	num	0	0	0	0	0	0	0	0	0
d4t	4th weekday defrost duration (only if dCt=4).	0...250	num	0	0	0	0	0	0	0	0	0
d4S	4th weekday defrost end temperature (only if dCt=4).	-58.0...302	°C/°F	0.0	0.0	0.0	0.0	0.0	0.0	0.0	0.0	0.0
d5H	5th weekday defrost start hour (only if dCt=4). • d4H...23 = start hour • 24 = disabled	d4H...24	flag	24	24	24	24	24	24	24	24	24
d5n	5th weekday defrost start minutes (only if dCt=4).	0...59	num	0	0	0	0	0	0	0	0	0
d5t	5th weekday defrost duration (only if dCt=4).	0...250	num	0	0	0	0	0	0	0	0	0
d5S	5th weekday defrost end temperature (only if dCt=4).	-58.0...302	°C/°F	0.0	0.0	0.0	0.0	0.0	0.0	0.0	0.0	0.0
d6H	6th weekday defrost start hour (only if dCt=4). • d5H...23 = start hour • 24 = disabled	d5H...24	flag	24	24	24	24	24	24	24	24	24
d6n	6th weekday defrost start minutes (only if dCt=4).	0...59	num	0	0	0	0	0	0	0	0	0
d6t	6th weekday defrost duration (only if dCt=4).	0...250	num	0	0	0	0	0	0	0	0	0
d6S	6th weekday defrost end temperature (only if dCt=4).	-58.0...302	°C/°F	0.0	0.0	0.0	0.0	0.0	0.0	0.0	0.0	0.0
F1H	1st weekend/holiday defrost start hour (only if dCt=4). • 0...23 = start hour • 24 = disabled	0...24	flag	0	0	0	0	0	0	0	0	0
F1n	1st weekend/holiday defrost start minutes (only if dCt=4).	0...59	num	0	0	0	0	0	0	0	0	0
F1t	1st weekend/holiday defrost duration (only if dCt=4).	0...250	num	0	0	0	0	0	0	0	0	0
F1S	1st weekend/holiday defrost end temperature (only if dCt=4).	-58.0...302	°C/°F	0.0	0.0	0.0	0.0	0.0	0.0	0.0	0.0	0.0
F2H	2nd weekend/holiday defrost start hour (only if dCt=4). • F1H...23 = start hour • 24 = disabled	F1H...24	flag	6	6	6	6	6	6	6	6	6
F2n	2nd weekend/holiday defrost start minutes (only if dCt=4).	0...59	num	0	0	0	0	0	0	0	0	0

PAR	Description	Range	UM	Value	AP1	AP2	AP3	AP4	AP5	AP6	AP7	AP8
F2t	2nd weekend/holiday defrost duration (only if dCt=4).	0...250	num	0	0	0	0	0	0	0	0	0
F2S	2nd weekend/holiday defrost end temperature (only if dCt=4).	-58.0...302	°C/°F	0.0	0.0	0.0	0.0	0.0	0.0	0.0	0.0	0.0
F3H	3rd weekend/holiday defrost start hour (only if dCt=4). • F2H...23 = start hour • 24 = disabled	F2H...24	flag	12	12	12	12	12	12	12	12	12
F3n	3rd weekend/holiday defrost start minutes (only if dCt=4).	0...59	num	0	0	0	0	0	0	0	0	0
F3t	3rd weekend/holiday defrost duration (only if dCt=4).	0...250	num	0	0	0	0	0	0	0	0	0
F3S	3rd weekend/holiday defrost end temperature (only if dCt=4).	-58.0...302	°C/°F	0.0	0.0	0.0	0.0	0.0	0.0	0.0	0.0	0.0
F4H	4th weekend/holiday defrost start hour (only if dCt=4). • F3H...23 = start hour • 24 = disabled	F3H...24	flag	18	18	18	18	18	18	18	18	18
F4n	4th weekend/holiday defrost start minutes (only if dCt=4).	0...59	num	0	0	0	0	0	0	0	0	0
F4t	4th weekend/holiday defrost duration (only if dCt=4).	0...250	num	0	0	0	0	0	0	0	0	0
F4S	4th weekend/holiday defrost end temperature (only if dCt=4).	-58.0...302	°C/°F	0.0	0.0	0.0	0.0	0.0	0.0	0.0	0.0	0.0
F5H	5th weekend/holiday defrost start hour (only if dCt=4). • F4H...23 = start hour • 24 = disabled	F4H...24	flag	24	24	24	24	24	24	24	24	24
F5n	5th weekend/holiday defrost start minutes (only if dCt=4).	0...59	num	0	0	0	0	0	0	0	0	0
F5t	5th weekend/holiday defrost duration (only if dCt=4).	0...250	num	0	0	0	0	0	0	0	0	0
F5S	5th weekend/holiday defrost end temperature (only if dCt=4).	-58.0...302	°C/°F	0.0	0.0	0.0	0.0	0.0	0.0	0.0	0.0	0.0
F6H	6th weekend/holiday defrost start hour (only if dCt=4). • F5H...23 = start hour • 24 = disabled	F5H...24	flag	24	24	24	24	24	24	24	24	24
F6n	6th weekend/holiday defrost start minutes (only if dCt=4).	0...59	num	0	0	0	0	0	0	0	0	0
F6t	6th weekend/holiday defrost duration (only if dCt=4).	0...250	num	0	0	0	0	0	0	0	0	0
F6S	6th weekend/holiday defrost end temperature (only if dCt=4).	-58.0...302	°C/°F	0.0	0.0	0.0	0.0	0.0	0.0	0.0	0.0	0.0
Fan												
FP1	Sets the probe used by the evaporator fans during normal operation. • diS (0) = disabled • Pb1 (1) = probe Pb1 • Pb2 (2) = probe Pb2 • Pb3 (3) = probe Pb3 • Pb4 (4) = probe Pb4 • Pb5 (5) = probe Pb5 • Pbi (6) = virtual probe • LP (7) = remote probe • PFi (8) = filtered virtual probe.	diS, Pb1...Pb5, Pbi, LP, PFi	num	Pb2	Pb2	Pb2	Pb2	Pb2	Pb2	Pb2	Pb2	Pb3
FP2	Sets the probe used by the evaporator fans during defrost. Same as FP1.	diS, Pb1...Pb5, Pbi, LP, PFi	num	Pb2	Pb2	Pb2	Pb2	Pb2	Pb2	Pb2	Pb2	Pb2

PAR	Description	Range	UM	Value	AP1	AP2	AP3	AP4	AP5	AP6	AP7	AP8																																																																																												
FPt	Parameter Fst management mode. <ul style="list-style-type: none"> AbS (0) = absolute value rEL (1) = relative value 	AbS/rEL	flag	AbS	AbS	AbS	AbS	AbS	AbS	AbS	AbS	AbS																																																																																												
FSt	Fan disabling temperature. If the value read is greater than FSt , the fans will be stopped. The value is positive or negative (only if FP1 ≠dis).	-58.0...302	°C/°F	5.0	5.0	5.0	5.0	5.0	5.0	5.0	5.0	5.0																																																																																												
FAd	Evaporator fan activation differential (only if FP1 ≠dis).	1.0...25.0	°C/°F	1.0	1.0	1.0	1.0	1.0	1.0	1.0	1.0	1.0																																																																																												
Fdt	Evaporator fan activation delay after a defrost.	0...250	min	0	0	0	0	0	0	0	0	0																																																																																												
dt	Dripping time.	0...250	min	0	0	0	0	0	0	0	0	0																																																																																												
dFd	Evaporator fan operating mode during a defrost. <ul style="list-style-type: none"> OFF(0) = Fans off On(1) = Fans on 	OFF/On	flag	On	On	On	On	On	On	On	On	On																																																																																												
FCO	Evaporator fan operating mode. <table border="1" data-bbox="300 770 715 1361"> <thead> <tr> <th rowspan="2">Pb2</th> <th rowspan="2">H42</th> <th rowspan="2">FCo</th> <th colspan="2">day</th> <th colspan="2">night</th> </tr> <tr> <th>Cn</th> <th>Cf</th> <th>Cn</th> <th>Cf</th> </tr> </thead> <tbody> <tr> <td rowspan="5">ok</td> <td rowspan="5">y</td> <td>0</td> <td>T</td> <td>Off</td> <td>T</td> <td>Off</td> </tr> <tr> <td>1</td> <td>T</td> <td>T</td> <td>T</td> <td>T</td> </tr> <tr> <td>2</td> <td>T</td> <td>T</td> <td>T</td> <td>T</td> </tr> <tr> <td>3</td> <td>T</td> <td>DCd</td> <td>T</td> <td>DCn</td> </tr> <tr> <td>4</td> <td>T</td> <td>DCd</td> <td>T</td> <td>DCn</td> </tr> <tr> <td rowspan="5">no</td> <td rowspan="5">n</td> <td>0</td> <td>On</td> <td>Off</td> <td>On</td> <td>Off</td> </tr> <tr> <td>1</td> <td>On</td> <td>On</td> <td>On</td> <td>On</td> </tr> <tr> <td>2</td> <td>DCd</td> <td>DCd</td> <td>DCn</td> <td>DCn</td> </tr> <tr> <td>3</td> <td>On</td> <td>DCd</td> <td>On</td> <td>DCn</td> </tr> <tr> <td>4</td> <td>On</td> <td>DCd</td> <td>On</td> <td>DCn</td> </tr> <tr> <td rowspan="5">ko</td> <td rowspan="5">y</td> <td>0</td> <td>DCd</td> <td>Off</td> <td>DCn</td> <td>Off</td> </tr> <tr> <td>1</td> <td>On</td> <td>Off</td> <td>On</td> <td>Off</td> </tr> <tr> <td>2</td> <td>DCd</td> <td>DCd</td> <td>DCn</td> <td>DCn</td> </tr> <tr> <td>3</td> <td>DCd</td> <td>DCd</td> <td>DCn</td> <td>DCn</td> </tr> <tr> <td>4</td> <td>DCd</td> <td>DCd</td> <td>DCn</td> <td>DCn</td> </tr> </tbody> </table> Headings legend: <ul style="list-style-type: none"> Pb2 = probe Pb2 status day = day mode night = night mode Cn = compressor on Cf = compressor off. Status legend: <ul style="list-style-type: none"> ok = probe present ko = probe in error E2 no = no probe T = thermostat controlled fans On = fans on Off = fans off DCd = day duty cycle DCn = night duty cycle. 	Pb2	H42	FCo	day		night		Cn	Cf	Cn	Cf	ok	y	0	T	Off	T	Off	1	T	T	T	T	2	T	T	T	T	3	T	DCd	T	DCn	4	T	DCd	T	DCn	no	n	0	On	Off	On	Off	1	On	On	On	On	2	DCd	DCd	DCn	DCn	3	On	DCd	On	DCn	4	On	DCd	On	DCn	ko	y	0	DCd	Off	DCn	Off	1	On	Off	On	Off	2	DCd	DCd	DCn	DCn	3	DCd	DCd	DCn	DCn	4	DCd	DCd	DCn	DCn	0...4	num	2	2	2	2	2	2	2	2	2
Pb2	H42				FCo	day		night																																																																																																
		Cn	Cf	Cn		Cf																																																																																																		
ok	y	0	T	Off	T	Off																																																																																																		
		1	T	T	T	T																																																																																																		
		2	T	T	T	T																																																																																																		
		3	T	DCd	T	DCn																																																																																																		
		4	T	DCd	T	DCn																																																																																																		
no	n	0	On	Off	On	Off																																																																																																		
		1	On	On	On	On																																																																																																		
		2	DCd	DCd	DCn	DCn																																																																																																		
		3	On	DCd	On	DCn																																																																																																		
		4	On	DCd	On	DCn																																																																																																		
ko	y	0	DCd	Off	DCn	Off																																																																																																		
		1	On	Off	On	Off																																																																																																		
		2	DCd	DCd	DCn	DCn																																																																																																		
		3	DCd	DCd	DCn	DCn																																																																																																		
		4	DCd	DCd	DCn	DCn																																																																																																		
Fod	Evaporator fan status with door open. <ul style="list-style-type: none"> OFF(0) = Fans off On(1) = Fans on 	OFF/On	flag	OFF	OFF	OFF	OFF	OFF	OFF	OFF	OFF	OFF																																																																																												
FdC	Evaporator fan shutoff delay after compressor deactivation.	0...250	min	0	0	0	0	0	0	0	0	0																																																																																												
FOn	Fan on time for day duty cycle. Applies when Duty cycle mode is active (see FCO).	0...250	min	1	1	1	1	1	1	1	1	1																																																																																												

PAR	Description	Range	UM	Value	AP1	AP2	AP3	AP4	AP5	AP6	AP7	AP8
FOF	Fan off time for day duty cycle. Applies when Duty cycle mode is active (see FCO).	0...250	min	0	0	0	0	0	0	0	0	0
Fnn	Fan on time for night duty cycle. Applies when Duty cycle mode is active (see FCO).	0...250	min	0	0	0	0	0	0	0	0	0
FnF	Fan off time for night duty cycle. Applies when Duty cycle mode is active (see FCO).	0...250	min	0	0	0	0	0	0	0	0	0
FE (Modulated Fans)												
FE1	Sets the probe used by the modulated fans. <ul style="list-style-type: none"> • diS (0) = disabled • Pb1 (1) = probe Pb1 • Pb2 (2) = probe Pb2 • Pb3 (3) = probe Pb3 • Pb4 (4) = probe Pb4 • Pb5 (5) = probe Pb5 • Pb6 (6) = probe Pb6 • Pb7 (7) = probe Pb7 • LP (8) = remote probe (Link²) • rP (9) = remote probe • Pbi (10) = virtual probe • PFi (11) = filtered virtual probe • PbC (12) = KDX terminal probe 	diS, Pb1...Pb7, LP, rP, Pbi, PFi, PbC	num	0	0	0	0	0	0	0	0	0
FEt	FES differential management mode. <ul style="list-style-type: none"> • AbS (0) = absolute value • rEL (1) = relative value 	AbS/rEL	flag	AbS	AbS	AbS	AbS	AbS	AbS	AbS	AbS	AbS
FES	"Modulated fans" regulator inhibiting temperature.	-58.0...302	°C/°F	0.0	0.0	0.0	0.0	0.0	0.0	0.0	0.0	0.0
FEd	Tripping differential for "modulated fans" regulator (absolute or relative).	0.1...50.0	°C/°F	0.1	0.1	0.1	0.1	0.1	0.1	0.1	0.1	0.1
FEu	Threshold value (Cut-OFF) on "modulated fans" regulator.	0.0...25.0	°C/°F	2.0	2.0	2.0	2.0	2.0	2.0	2.0	2.0	2.0
FEC	Activation differential for the threshold value (Cut-OFF) on "modulated fans" regulator.	0.1...25.0	°C/°F	5.0	5.0	5.0	5.0	5.0	5.0	5.0	5.0	5.0
FEr	Fan deactivation delay time from compressor stoppage.	0...250	min	0	0	0	0	0	0	0	0	0
FE2	Minimum implementation percentage applied to the analog output in day mode.	0...100	%	20	20	20	20	20	20	20	20	20
FE3	Maximum implementation percentage applied to the analog output in day mode with the compressor running.	0...100	%	100	100	100	100	100	100	100	100	100
FE4	Maximum implementation percentage applied to the analog output in day mode with the compressor off.	0...100	%	60	60	60	60	60	60	60	60	60
FE5	Minimum implementation percentage applied to the analog output in night mode.	0...100	%	20	20	20	20	20	20	20	20	20
FE6	Maximum implementation percentage applied to the analog output in night mode with the compressor running.	0...100	%	80	80	80	80	80	80	80	80	80
FE7	Maximum implementation percentage applied to the analog output in night mode with the compressor off.	0...100	%	60	60	60	60	60	60	60	60	60
FE8	Implementation percentage applied to the analog output during defrosting.	0...100	%	0	0	0	0	0	0	0	0	0
FE9	Implementation percentage applied to the analog output in the event of a probe error.	0...100	%	60	60	60	60	60	60	60	60	60
FEA	Modulated fans pick-up percentage. Used to overcome thermal inertia of the fans in the event of extended usage at low speed.	0...100	%	100	100	100	100	100	100	100	100	100
FEb	Modulated fans pick-up time.	0...250	s	60	60	60	60	60	60	60	60	60
FEP	Fan forcing procedure duration at pick-up speed.	0...250	min	30	30	30	30	30	30	30	30	30
AL (Alarms)												

PAR	Description	Range	UM	Value	AP1	AP2	AP3	AP4	AP5	AP6	AP7	AP8
rA1	Sets probe 1 used for temperature alarms. <ul style="list-style-type: none"> diS (0) = disabled Pb1 (1) = probe Pb1 Pb2 (2) = probe Pb2 Pb3 (3) = probe Pb3 Pb4 (4) = probe Pb4 Pb5 (5) = probe Pb5 Pbi (6) = virtual probe Pfi (7) = filtered virtual probe 	diS, Pb1...Pb5, Pbi, LP, Pfi	num	Pb1	Pb1	Pb1	Pb1	Pb1	Pb1	Pb1	Pb1	Pb1
rA2	Sets probe 2 used for temperature alarms. Same as rA1 .	diS, Pb1...Pb5, Pbi, LP, Pfi	num	diS	diS	diS	diS	diS	diS	diS	diS	Pb2
Att	Sets the absolute or relative value for parameters HA1/HA2 and LA1/LA2 . <ul style="list-style-type: none"> AbS (0) = absolute value rEL (1) = relative value 	AbS/rEL	flag	rEL	rEL	rEL	rEL	rEL	rEL	rEL	rEL	rEL
AFd	Alarm activation differential.	0.1...25.0	°C/°F	2.0	2.0	2.0	2.0	2.0	2.0	2.0	2.0	2.0
HA1	Probe 1 maximum alarm (only if rA1 ≠diS). Temperature value (Att function) which, when exceeded, will lead to the activation of alarm signaling.	LA1...302	°C/°F	10.0	10.0	10.0	10.0	10.0	10.0	10.0	10.0	10.0
LA1	Probe 1 minimum alarm (only if rA1 ≠diS). Temperature value (Att function) which, when exceeded, will lead to the activation of alarm signaling.	-58.0...HA1	°C/°F	-10.0	-10.0	-10.0	-10.0	-10.0	-10.0	-10.0	-10.0	-10.0
HA2	Probe 2 maximum alarm (only if rA2 ≠diS). Temperature value (Att function) which, when exceeded, will lead to the activation of alarm signaling.	LA2...302	°C/°F	0.0	0.0	0.0	0.0	0.0	0.0	0.0	0.0	0.0
LA2	Probe 2 minimum alarm (only if rA2 ≠diS). Temperature value (Att function) which, when exceeded, will lead to the activation of alarm signaling.	-58.0...HA2	°C/°F	0.0	0.0	0.0	0.0	0.0	0.0	0.0	0.0	0.0
PAO	Alarm exclusion time when switching on the device, after a power failure. Refers only to high and low temperature alarms.	0...10	hours	3	3	3	3	3	3	3	3	3
dAO	Temperature alarm exclusion time after defrosting.	0...250	min	30	30	30	30	30	30	30	30	30
OAO	Alarm signaling delay (for high and low temperature) after deactivation of the digital input (door closure).	0...10	hours	0	0	0	0	0	0	0	0	0
tdO	Door open alarm activation delay time.	0...250	min	0	0	0	0	0	0	0	0	0
tA1	Temperature alarm 1 signaling delay (only if rA1 ≠diS). Refers only to high and low temperature alarms LA1 and HA1 .	0...250	min	30	30	30	30	30	30	30	30	30
tA2	Temperature alarm 2 signaling delay (only if rA2 ≠diS). Refers only to high and low temperature alarms LA2 and HA2 .	0...250	min	0	0	0	0	0	0	0	0	0
dAt	Defrost ended due to timeout alarm indication. <ul style="list-style-type: none"> no(0) = alarm not activated yES(1) = alarm activated 	no/yES	flag	no	no	no	no	no	no	no	no	no
EAL	An external alarm inhibits the regulators. <ul style="list-style-type: none"> 0 = does not inhibit the regulators 1 = compressor and defrost inhibited 2 = fans, compressor and defrost inhibited; 	0/1/2	num	0	0	0	0	0	0	0	0	0

PAR	Description	Range	UM	Value	AP1	AP2	AP3	AP4	AP5	AP6	AP7	AP8
rA3	Sets the probe used by the leak detector. <ul style="list-style-type: none"> diS (0) = disabled Pb1 (1) = probe Pb1 Pb2 (2) = probe Pb2 Pb3 (3) = probe Pb3 Pb4 (4) = probe Pb4 Pb5 (5) = probe Pb5 Pbi (6) = virtual probe PFi (7) = filtered virtual probe PbC (8) = KDX terminal probe 	diS, Pb1...Pb5, Pbi, PFi, PbC	num	diS	diS	diS	diS	diS	diS	diS	diS	diS
ALL	Leak alarm detector minimum alarm threshold.	0.0...ALH	°C/°F	30.0	30.0	30.0	30.0	30.0	30.0	30.0	30.0	30.0
ALH	Leak alarm detector maximum alarm threshold.	ALL...100	°C/°F	50.0	50.0	50.0	50.0	50.0	50.0	50.0	50.0	50.0
dAL	Leak detector alarm activation differential.	0.1...100	°C/°F	5.0	5.0	5.0	5.0	5.0	5.0	5.0	5.0	5.0
AL1	Time the value read by the leak detector probe remains under the ALL threshold.	0...250	min	1	1	1	1	1	1	1	1	1
AL2	Time the value read by the leak detector probe remains above the ALH threshold.	0...250	min	0	0	0	0	0	0	0	0	0
tP	Alarm acknowledgment with any key. <ul style="list-style-type: none"> no (0) = silencing disabled yES (1) = silencing enabled. 	no/yES	flag	yES	yES	yES	yES	yES	yES	yES	yES	yES
Art	Link 2 supervision alarm activation period. Sets the time period for verifying network operation. The AtS alarm is not shown on the display: <ul style="list-style-type: none"> if Art=0 it is disabled if Art=1 it is reset automatically after 5 minutes if Art≥2 it is reset automatically after 10 minutes. 	0...250	min*10	0	0	0	0	0	0	0	0	0
Lit (Lights and Digital Inputs)												
dSd	Enable light relay from door switch. <ul style="list-style-type: none"> no (0) = door opening does not switch on the light yES (1) = door opening switches on the light (if it was off). 	no/yES	flag	no	no	no	no	no	no	no	no	no
dLt	Light relay (cold room light) deactivation (switch-off) delay. The cold room light remains on for dLt minutes after the door is closed (only if dSd =yES).	0...250	min	0	0	0	0	0	0	0	0	0
OFL	Enables cold room light switch-off via key, even if the delay dLt is enabled. <ul style="list-style-type: none"> no (0) = no yES (1) = yes 	no/yES	flag	no	no	no	no	no	no	no	no	no
dOd	Digital input shuts off utilities. <ul style="list-style-type: none"> 0 = disabled 1 = disables fans 2 = disables compressor 3 = disables fans and compressor. 	0...3	num	0	0	0	0	0	0	0	0	0
dOA	Behavior forced from digital input (only if PEA ≠0). <ul style="list-style-type: none"> 0 = compressor activation 1 = fan activation 2 = compressor and fan activation 3 = compressor deactivation 4 = fan deactivation 5 = compressor and fan deactivation. 	0...5	num	0	0	0	0	0	0	0	0	0

PAR	Description	Range	UM	Value	AP1	AP2	AP3	AP4	AP5	AP6	AP7	AP8
PEA	Selection of digital input with resource inhibiting/unlocking function. <ul style="list-style-type: none"> 0 = function disabled 1 = associated with door switch 2 = associated with external alarm 3 = associated with external alarm and door switch. 	0...3	num	0	0	0	0	0	0	0	0	0
dCO	Compressor activation/switch-off delay after consent (DI activation).	0...250	min	0	0	0	0	0	0	0	0	0
dFO	Fan activation/switch-off delay after consent (DI activation).	0...250	min	0	0	0	0	0	0	0	0	0
ASb	Sets whether the light key and light enabling when door opened function can be activated even while the controller is OFF. <ul style="list-style-type: none"> no (0) = disables the relay until stand-by mode has been exited yES (1) = the relay status does not change and it can be activated/disabled via key. 	no/yES	flag	no	no	no	no	no	no	no	no	no
Lin (Link²)												
L00	Sets which probe to share via Link ² : <ul style="list-style-type: none"> diS (0) = disabled Pb1 (1) = probe Pb1 Pb2 (2) = probe Pb2 Pb3 (3) = probe Pb3 Pb4 (4) = probe Pb4 Pb5 (5) = probe Pb5 Pbi (6) = virtual probe Pfi (7) = filtered virtual probe 	diS, Pb1...Pb5, Pbi, LP, Pfi	num	diS	diS	diS	diS	diS	diS	diS	diS	diS
L01	Shares the displayed value with the Link 2 network. <ul style="list-style-type: none"> 0 = prevents sending the displayed value from the device to the Link2 network 1 = enables sending the displayed value from the device to the Link2 network² 2 = displays the value of the device with setting L01 = 1. 	0/1/2	num	0	0	0	0	0	0	0	0	0
L02	Sends the Setpoint value to the Link 2 network when it is changed. <ul style="list-style-type: none"> no (0) = no yES (1) = yes. 	no/yES	flag	no	no	no	no	no	no	no	no	no
L03	Enables the sending of the defrost request to the Link 2 network. <ul style="list-style-type: none"> 0 = send defrost request disabled 1 = master device for sending simultaneous defrost request 2 = master device for sending sequential defrost request 	0/1/2	num	0	0	0	0	0	0	0	0	0
L04	Defrost end method. <ul style="list-style-type: none"> ind (0) = independent dEP (1) = dependent. Waits for all controllers to have finished defrosting. 	ind/dEP	flag	ind	ind	ind	ind	ind	ind	ind	ind	ind
L05	Enable Stand-by command synchronization <ul style="list-style-type: none"> no (0) = no yES (1) = yes 	no/yES	flag	no	no	no	no	no	no	no	no	no
L06	Enable light command synchronization <ul style="list-style-type: none"> no (0) = no yES (1) = yes 	no/yES	flag	no	no	no	no	no	no	no	no	no

PAR	Description	Range	UM	Value	AP1	AP2	AP3	AP4	AP5	AP6	AP7	AP8
L07	Enable Energy Saving command synchronization <ul style="list-style-type: none"> no (0) = no yES (1) = yes 	no/yES	flag	no	no	no	no	no	no	no	no	no
L08	Enable AUX command synchronization <ul style="list-style-type: none"> no (0) = no yES (1) = yes 	no/yES	flag	no	no	no	no	no	no	no	no	no
L09	Enables sharing of the saturation probe (pressure). <ul style="list-style-type: none"> no (0) = no yES (1) = yes 	no/yES	flag	no	no	no	no	no	no	no	no	no
L10	Sets the wait timeout for the end of dependent defrosts.	0...250	min	30	30	30	30	30	30	30	30	30
L11	Sets the number of devices connected to Link ² . If the number of devices differs from the set value, a Link 2 alarm will be activated (ELi).	0..8	num	0	0	0	0	0	0	0	0	0
L12	Set how to share alarms <ul style="list-style-type: none"> 0 = function disabled 1 = alarm relay master 2 = alarm relay slave 	0/1/2	num	0	0	0	0	0	0	0	0	0
L13	Link 2 serial frame configuration <ul style="list-style-type: none"> 0 = DOMINO ZERO operation 1 = standard operation (with non-DOMINO ZERO device) 	0/1	flag	0	0	0	0	0	0	0	0	0
L14	Force cooling mode <ul style="list-style-type: none"> 0 = disabled 1 = force cooling mode when at least one device in a Link 2 network is in defrost 	0/1	flag	0	0	0	0	0	0	0	0	0
dEC (Deep cooling cycle)												
dCS	Deep cooling cycle setpoint	-58.0...302	°C/°F	0	0	0	0	0	0	0	0	0
tdC	Deep cooling cycle duration	0...250	min	0	0	0	0	0	0	0	0	0
dcc	Defrost delay after a deep cooling cycle	0...250	min	0	0	0	0	0	0	0	0	0
EnS (Energy Saving)												
ESt	Type of event activated via RTC. <ul style="list-style-type: none"> 0 = disabled 1 = Energy Saving 2 = Energy Saving + Light off 3 = Energy Saving + Light off + AUX output active 4 = Device off 5 = Energy saving + Terminal buzzer silencing 6 = Energy saving + Light off + Terminal buzzer silencing 7 = Energy Saving + Light off + AUX output active + Terminal buzzer silencing 8 = Device off + Terminal buzzer silencing 	0...8	num	0	0	0	0	0	0	0	0	0
ESF	Activates night mode (energy saving) for the fans. <ul style="list-style-type: none"> no (0) = disabled yES (1) = enabled if energy saving mode is active (only if ES_t≠0 and ES_t≠4). 	no/yES	flag	0	0	0	0	0	0	0	0	0
Cdt	Door closure time due to dynamic setpoint activation.	0...255	min*10	0	0	0	0	0	0	0	0	0
ESO	Cumulative door open time due to dynamic setpoint disabling.	0...10	num	0	0	0	0	0	0	0	0	0

PAR	Description	Range	UM	Value	AP1	AP2	AP3	AP4	AP5	AP6	AP7	AP8
OS1	Offset on setpoint 1 (SP1) in energy saving mode.	-50.0...50.0	°C/°F	3.0	3.0	3.0	3.0	3.0	3.0	3.0	3.0	3.0
OS2	Offset on setpoint 2 (SP2) in energy saving mode (only if rE ≠0).	-50.0...50.0	°C/°F	0.0	0.0	0.0	0.0	0.0	0.0	0.0	0.0	0.0
Od1	Energy saving offset 1 for refrigerated display cabinets.	-50.0...50.0	°C/°F	0.0	0.0	0.0	0.0	0.0	0.0	0.0	0.0	0.0
Od2	Energy saving offset 2 for refrigerated display cabinets (only if rE ≠0).	-50.0...50.0	°C/°F	0.0	0.0	0.0	0.0	0.0	0.0	0.0	0.0	0.0
dn1	Differential on setpoint 1 (SP1) in energy saving mode.	-58.0...302	°C/°F	4.0	4.0	4.0	4.0	4.0	4.0	4.0	4.0	4.0
dn2	Differential on setpoint 2 (SP2) in energy saving mode (only if rE ≠0).	-58.0...302	°C/°F	4.0	4.0	4.0	4.0	4.0	4.0	4.0	4.0	4.0
EdH	Weekday Energy Saving start hour. • 0...23 = start hour • 24 = disabled	0...24	hours	24	24	24	24	24	24	24	24	24
Edn	Weekday Energy Saving start minutes.	0...59	min	0	0	0	0	0	0	0	0	0
Edd	Weekday Energy Saving duration.	1...72	hours	10	10	10	10	10	10	10	10	10
EFH	Weekend/holiday Energy Saving start hour. • 0...23 = start hour • 24 = disabled	0...24	hours	24	24	24	24	24	24	24	24	24
EFn	Weekend/holiday Energy Saving start minutes.	0...59	min	0	0	0	0	0	0	0	0	0
EFd	Weekend/holiday Energy Saving duration.	1...72	hours	24	24	24	24	24	24	24	24	24
FrH (Anti-condensation heaters - Frame Heater)												
FH	Sets which probes use the anti-condensation heaters (FH). • diS (0) = disabled • dc (1) = duty cycle • Pb1 (2) = probe Pb1 • Pb2 (3) = probe Pb2 • Pb3 (4) = probe Pb3 • Pb4 (5) = probe Pb4 • Pb5 (6) = probe Pb5 • Pbi (7) = virtual probe • Pfi (8) = filtered virtual probe • PbC (9) = KDX terminal probe	diS, dc, Pb1...Pb5, Pbi, Pfi, PbC	num	diS	diS	diS	diS	diS	diS	diS	diS	diS
FHt	Anti-condensation heater operating period duration (FH), only used if the OC output is used with SSR relay.	1...250	s*10	30	30	30	30	30	30	30	30	30
FH0	Sets the Setpoint corresponding to the anti-condensation heaters (only if FH ≠dis and FH ≠dc).	-58.0...302	°C/°F	0.0	0.0	0.0	0.0	0.0	0.0	0.0	0.0	0.0
FH1	Sets the Offset corresponding to the anti-condensation heaters (only if FH ≠dis and FH ≠dc).	0.0...25.0	°C/°F	0.0	0.0	0.0	0.0	0.0	0.0	0.0	0.0	0.0
FH2	Sets the Band corresponding to the anti-condensation heaters (only if FH ≠dis and FH ≠dc).	-58.0...302	°C/°F	0.0	0.0	0.0	0.0	0.0	0.0	0.0	0.0	0.0
FH3	Sets the minimum percentage for the anti-condensation heaters (only if FH ≠dis and FH ≠dc).	0...100	%	0	0	0	0	0	0	0	0	0
FH4	Sets the maximum percentage for the day Duty cycle.	0...100	%	75	75	75	75	75	75	75	75	75
FH5	Sets the maximum percentage for the night Duty cycle.	0...100	%	50	50	50	50	50	50	50	50	50
FH6	Sets the anti-condensation heater percentage during defrost.	0...100	%	100	100	100	100	100	100	100	100	100
Add (Communication)												
Adr	Modbus protocol controller address.	1...250	flag	1 (not in applications)								

PAR	Description	Range	UM	Value	AP1	AP2	AP3	AP4	AP5	AP6	AP7	AP8
bAU	Modbus Baudrate selection. <ul style="list-style-type: none"> • 96 (0) = 9600 • 192 (1) = 19200 • 384 (2) = 38400 	96/192/384	num	192 (not in applications)								
Pty	Modbus parity bit. <ul style="list-style-type: none"> • n(0) = none • E(1) = even • o(2) = odd. 	n/E/o	num	E (not in applications)								
diS (Display)												
LOC	LOCK. Setpoint change lock. It is still possible to enter parameter programming and change them, including the status of this parameter in order to unlock the terminal. <ul style="list-style-type: none"> • no (0) = no • yES (1) = yes 	no/yES	flag	no	no	no	no	no	no	no	no	no
PS1	PAssword 1. When enabled (PS1 ≠0) this is the access key for level 1 parameters (User).	0...250	num	0	0	0	0	0	0	0	0	0
PS2	PAssword 2. When enabled (PS2 ≠0) this is the access key for level 2 parameters (Installer).	0...250	num	15	15	15	15	15	15	15	15	15
ndt	Display with decimal point. <ul style="list-style-type: none"> • no (0) = no (integers only) • yES (1) = yes (display with decimal). 	no/yES	flag	yES	yES	yES	yES	yES	yES	yES	yES	yES
CA1	Calibration of probe Pb1 (only if H41 ≠Pro). Positive or negative temperature values that are added to those read by Pb1. This sum is used for the displayed temperature as well as for the regulation.	-30.0...30.0	°C/°F	0.0	0.0	0.0	0.0	0.0	0.0	0.0	0.0	0.0
CA2	Calibration of probe Pb2 (only if H42 ≠Pro). Positive or negative temperature values that are added to those read by Pb2. This sum is used for the displayed temperature as well as for the regulation.	-30.0...30.0	°C/°F	0.0	0.0	0.0	0.0	0.0	0.0	0.0	0.0	0.0
CA3	Calibration of probe Pb3 (only if H43 ≠Pro). Positive or negative temperature values that are added to those read by Pb3. This sum is used for the displayed temperature as well as for the regulation.	-30.0...30.0	°C/°F	0.0	0.0	0.0	0.0	0.0	0.0	0.0	0.0	0.0
CA4	Calibration of probe Pb4 (only if H44 ≠Pro). Positive or negative temperature values that are added to those read by Pb4. This sum is used for the displayed temperature as well as for the regulation.	-30.0...30.0	°C/°F	0.0	0.0	0.0	0.0	0.0	0.0	0.0	0.0	0.0
CA5	Calibration of probe Pb5 (only if H45 ≠Pro). Positive or negative temperature values that are added to those read by Pb5. This sum is used for the displayed temperature as well as for the regulation.	-30.0...30.0	°C/°F	0.0	0.0	0.0	0.0	0.0	0.0	0.0	0.0	0.0
CA6	Calibration of pressure transducer Pb6 (4...20 mA) (only if H46 =Pro). Positive or negative temperature values that are added to those read by pressure transducer Pb6 (4...20 mA). This sum is used for the displayed temperature as well as for the regulation.	-30.0...30.0	°C/°F	0.0	0.0	0.0	0.0	0.0	0.0	0.0	0.0	0.0
CA7	Calibration of ratiometric transducer Pb7 (only if H47 =Pro). Positive or negative temperature values that are added to those read by ratiometric transducer Pb7. This sum is used for the displayed temperature as well as for the regulation.	-30.0...30.0	°C/°F	0.0	0.0	0.0	0.0	0.0	0.0	0.0	0.0	0.0
LdL	Minimum value that can be displayed by the device.	-58.0...HdL	°C/°F	-40.0	-40.0	-40.0	-40.0	-40.0	-40.0	-40.0	-40.0	-40.0

PAR	Description	Range	UM	Value	AP1	AP2	AP3	AP4	AP5	AP6	AP7	AP8
HdL	Maximum value that can be displayed by the device.	LdL...302	°C/°F	100	100	100	100	100	100	100	100	100
ddL	Display mode during defrosting. <ul style="list-style-type: none"> 0 = display the temperature read by the probe or the setpoint (see ddd) 1 = locks the reading at the temperature value read by the probe at the start of defrost until reaching SEt (or until the expiration of Ldd) 2 = displays label dEF during defrost until reaching SEt (or until the expiration of Ldd). 	0/1/2	num	0	0	0	0	0	0	0	0	0
Ldd	Display unlocking timeout value.	0...250	min	0	0	0	0	0	0	0	0	0
drO	Selects the unit of measure used when displaying the temperature read by the probes. <ul style="list-style-type: none"> C (0) = °C F (1) = °F 	C/F	flag	C	C	C	C	C	C	C	C	C
SbP	Selects the unit of measure for displaying the value read by the pressure sensors 4...20 mA (Pb6) and ratiometric sensors (Pb7). <ul style="list-style-type: none"> bar (0) = bar psi (1) = psi. 	bar/psi	flag	bar	bar	bar	bar	bar	bar	bar	bar	bar
rEP	Selects relative/absolute pressure. <ul style="list-style-type: none"> 0 = relative pressure 1 = absolute pressure 	0/1	flag	0 (not in applications)								
ddd	Sets the value to show on the display. <ul style="list-style-type: none"> SP1 (0) = setpoint SP1 Pb1 (1) = probe Pb1 Pb2 (2) = probe Pb2 Pb3 (3) = probe Pb3 Pb4 (4) = probe Pb4 Pb5 (5) = probe Pb5 Pbi (6) = virtual probe LP (7) = remote probe PFi (8) = filtered virtual probe 	SP1, Pb1...Pb5, Pbi, LP, PFi	num	Pb1	Pb1	Pb1	Pb1	Pb1	Pb1	Pb1	Pb1	Pb1
ddE	Sets the value to show on the display of the Echo module. <ul style="list-style-type: none"> SP1 (0) = setpoint SP1 Pb1 (1) = probe Pb1 Pb2 (2) = probe Pb2 Pb3 (3) = probe Pb3 Pb4 (4) = probe Pb4 Pb5 (5) = probe Pb5 Pbi (6) = virtual probe LP (7) = remote probe PFi (8) = filtered virtual probe PbC (9) = KDX terminal probe 	SP1, Pb1...Pb5, Pbi, LP, PFi, PbC	num	Pb1	Pb1	Pb1	Pb1	Pb1	Pb1	Pb1	Pb1	Pb1
HCP (HACCP)												
rPH	Sets which probe the HACCP alarms will use. <ul style="list-style-type: none"> diS (0) = disabled Pb1 (1) = probe Pb1 Pb2 (2) = probe Pb2 Pb3 (3) = probe Pb3 Pb4 (4) = probe Pb4 Pb5 (5) = probe Pb5 	diS, Pb1...Pb5	num	diS	diS	diS	diS	diS	diS	diS	diS	diS
CnF (Configuration)												

PAR	Description	Range	UM	Value	AP1	AP2	AP3	AP4	AP5	AP6	AP7	AP8
trA	<p>Selects the model of ratiometric transducer used.</p> <ul style="list-style-type: none"> USE (0) = Generic Probe Set by customer rA1 (1) = EWPA 010 R 0/5 V 0/10 BAR FEMALE rA2 (2) = EWPA 030 R 0/5 V 0/30 BAR FEMALE rA3 (3) = EWPA 050 R 0/5 V 0/50 BAR FEMALE rA4 (4) = AKS 32R -1 ...6 BAR rA5 (5) = AKS 32R -1 ...12 BAR rA6 (6) = AKS 32R -1 ... 20 BAR rA7 (7) = AKS 32R -1 ... 34 BAR rA8 (8) = Reserved. <p>Note: The upper and lower limits of probes rA1... rA8 are pre-set (and cannot be changed), while if you select USE you will need to set them via parameters H05 and H06.</p>	USE, rA1...rA8	num	USE (not in applications)								
H00	<p>Select probe type used (Pb1...Pb5).</p> <ul style="list-style-type: none"> ntc (0) = NTC Ptc (1) = PTC Pt1 (2) = Pt1000 	ntc, PTC, Pt1	num	ntc	ntc	ntc	ntc	ntc	ntc	ntc	ntc	ntc
H02	<p>Key activation time, when configured with a second function. For the ESC, UP and DOWN keys configured with a second function (defrost, AUX, etc.), this sets the time for quick activation of that function. AUX and LIGHT are not included in this, as they have a fixed time of 0.5 seconds.</p>	0...250	s	5	5	5	5	5	5	5	5	5
H03	Lower limit for pressure transducer Pb6 4-20 mA (relative pressure).	-1.0...H04	bar	-1.0 (not in applications)								
H04	Upper limit for pressure transducer Pb6 4-20 mA (relative pressure).	H03...150	bar	7.0 (not in applications)								
H05	Lower limit for ratiometric transducer Pb7 (relative pressure).	-1.0...H06	bar	-1.0 (not in applications)								
H06	Upper limit for ratiometric transducer Pb7 (relative pressure).	H05...150	bar	7.0 (not in applications)								
08L	KDX analog input lower limit.	0...100	num	0 (not in applications)								
08H	KDX analog input upper limit.	0...100	num	100 (not in applications)								
H08	<p>Stand-by operating mode</p> <ul style="list-style-type: none"> 0 = display off; the regulators are active and the device signals possible alarms by reactivating the display 1 = display off; the regulators and the alarms are blocked 2 = the display shows the label "OFF"; the regulators and alarms are inhibited. 	0/1/2	num	2	2	2	2	2	2	2	2	2

PAR	Description	Range	UM	Value	AP1	AP2	AP3	AP4	AP5	AP6	AP7	AP8
H11	Configuration of digital input 1/polarity (Pb1) (only if H41=di). <ul style="list-style-type: none"> • 0 = disabled • ±1 = start of defrost • ±2 = end of defrost • ±3 = light • ±4 = energy saving • ±5 = AUX • ±6 = external alarm • ±7 = stand-by • ±8 = door switch • ±9 = preheat alarm • ±10 = reserved • ±11 = reserved • ±12 = reserved • ±13 = deep cooling cycle (DCC) • ±14 = force EEV deactivation • ±15 = force fan activation • ±16 = force OF1 (remote offset) • ±17 = general input • ±18 = force cooling • ±19 = panic alarm Note: <ul style="list-style-type: none"> • the + sign indicates that the input is active if the contact is closed. • the - sign indicates that the input is active if the contact is open. 	-19...+19	num	0	0	0	0	0	0	0	0	0
H12	Configuration of digital input 2/polarity (Pb2) (only if H42=di). Same as H11 .	-19...+19	num	0	0	0	0	0	0	0	0	0
H13	Configuration of digital input 3/polarity (Pb3) (only if H43=di). Same as H11 .	-19...+19	num	0	0	0	0	0	0	0	0	0
H14	Configuration of digital input 4/polarity (Pb4) (only if H44=di). Same as H11 .	-19...+19	num	0	0	0	0	0	0	0	0	0
H15	Configuration of digital input 5/polarity (Pb5) (only if H45=di). Same as H11 .	-19...+19	num	0	0	0	0	0	0	0	0	0
H16	Configuration of digital input 6/polarity (Pb6) (only if H46=di). Same as H11 .	-19...+19	num	0	0	0	0	0	0	0	0	0
H17	Configuration of digital input 7/polarity (Pb7) (only if H47=di). Same as H11 .	-19...+19	num	0	0	0	0	0	0	0	0	0
H18	Digital input 8/polarity (DI) configuration. Same as H11 .	-19...+19	num	0	0	0	0	-8	-8	-8	0	0
i01	Digital input 9/polarity (DI1 KDX) configuration. Same as H11 .	-19...+19	num	0	0	0	0	0	0	0	0	0
i02	Digital input 10/polarity (DI2 KDX) configuration. Same as H11 .	-19...+19	num	0	0	0	0	0	0	0	0	0
d1i	Unit of measure for digital inputs DI1 (Pb1), DI2 (Pb2), DI, i01 (DI1 KDX) and i02 (DI2 KDX). If one of the digital inputs indicated is configured as DI, the unit of measure can be set. <ul style="list-style-type: none"> • 0 = minutes • 1 = seconds. 	0/1	flag	0	0	0	0	0	0	0	0	0
d11	Digital input 1 activation delay (Pb1) (only if H41=di).	0...255	see d1i	0	0	0	0	0	0	0	0	0
d12	Digital input 2 activation delay (Pb2) (only if H42=di).	0...255	see d1i	0	0	0	0	0	0	0	0	0
d13	Digital input 3 activation delay (Pb3) (only if H43=di).	0...255	min	0	0	0	0	0	0	0	0	0
d14	Digital input 4 activation delay (Pb4) (only if H44=di).	0...255	min	0	0	0	0	0	0	0	0	0
d15	Digital input 5 activation delay (Pb5) (only if H45=di).	0...255	min	0	0	0	0	0	0	0	0	0

PAR	Description	Range	UM	Value	AP1	AP2	AP3	AP4	AP5	AP6	AP7	AP8
d16	Digital input 6 activation delay (Pb6) (only if H46=di).	0...255	min	0	0	0	0	0	0	0	0	0
d17	Digital input 7 activation delay (Pb7) (only if H47=di).	0...255	min	0	0	0	0	0	0	0	0	0
d18	Digital input 8 (DI) activation delay.	0...255	min	0	0	0	0	0	0	0	0	0
01i	Digital input 9 (DI1 KDX) activation delay.	0...255	min	0	0	0	0	0	0	0	0	0
02i	Digital input 10 (DI2 KDX) activation delay.	0...255	min	0	0	0	0	0	0	0	0	0
H21	Digital output 1 configuration (OUT 1): <ul style="list-style-type: none"> • 0 = disabled • 1 = compressor • 2 = defrost 1 / hot gas valve • 3 = evaporator fans • 4 = alarm • 5 = AUX • 6 = Stand-by • 7 = Light • 8 = anti-condensation heaters • 9 = defrost 2 • 10 = reserved • 11 = condenser fans • 12 = AUX regulator • 13 = hot gas: evaporator suction valve • 14 = alarm with inverted polarity • 15 = casing heater • 16 = condensation collection heater • 17 = liquid valve • 18 = leak detector alarm • 19 = PAn alarm 	0...19	num	1	1	1	1	1	1	1	1	1
H22	Digital output 2 configuration (OUT 2). Same as H21.	0...19	num	3	3	3	3	3	3	3	3	3
H23	Digital output 3 configuration (OUT 3). Same as H21.	0...19	num	2	2	2	2	2	2	2	2	2
H24	Digital output 4 configuration (OUT 4). Same as H21.	0...19	num	7	7	7	7	7	7	7	7	7
H25	Digital output 5 configuration (OUT 5). Same as H21.	0...19	num	5	5	5	0	0	0	0	0	0
H27	Configuration of digital output 7 (Open Collector). Same as H21.	0...19	num	0	0	0	0	0	0	0	0	0
H29	Enables buzzer on the terminal. <ul style="list-style-type: none"> • diS (0) = buzzer disabled • En (1) = buzzer enabled. 	diS/En	flag	diS	diS	diS	diS	diS	diS	diS	diS	diS
d01	Digital output 8 configuration (OUT 4 KDX). Same as H21.	0...19	num	0	0	0	0	0	0	0	0	0
d02	Digital output 9 configuration (OUT 5 KDX). Same as H21.	0...19	num	0	0	0	0	0	0	0	0	0
H31	Configuration of the UP key. <ul style="list-style-type: none"> • 0 = Disabled • 1 = Defrost • 2 = Reduced set • 3 = Light • 4 = Energy saving • 5 = AUX • 6 = Stand-by • 7 = Deep cooling cycle (DCC) • 8 = Defrost start/stop • 9 = Cabinet cleaning function 	0...9	num	1	1	1	1	1	1	1	1	1
H32	Configuration of the DOWN key. Same as H31.	0...9	num	0	0	0	0	0	0	0	0	0
H33	Configuration of the ESC key. Same as H31.	0...9	num	6	6	6	6	6	6	6	6	6
H34	Configuration of the Free 1 key. Same as H31.	0...9	num	3	3	3	3	3	3	3	3	3

PAR	Description	Range	UM	Value	AP1	AP2	AP3	AP4	AP5	AP6	AP7	AP8
H35	Configuration of the Free 2 key. Same as H31.	0...9	num	6	6	6	6	6	6	6	6	6
H36	Configuration of the Free 3 key. Same as H31.	0...9	num	0	0	0	0	0	0	0	0	0
H37	Configuration of the Free 4 key. Same as H31.	0...9	num	0	0	0	0	0	0	0	0	0
H41	Configuration of analog input 1 type (Pb1). <ul style="list-style-type: none"> diS (0) = disabled di (1) = digital input Pro (2) = probe input 	diS, di, Pro	num	Pro	Pro	Pro	Pro	Pro	Pro	Pro	Pro	Pro
H42	Configuration of analog input 2 type (Pb2). Same as H41.	diS, di, Pro	num	Pro	Pro	Pro	Pro	Pro	Pro	Pro	Pro	Pro
H43	Configuration of analog input 3 type (Pb3). Same as H41.	diS, di, Pro	num	Pro	Pro	Pro	Pro	Pro	Pro	Pro	Pro	Pro
H44	Configuration of analog input 4 type (Pb4). Same as H41.	diS, di, Pro	num	diS	diS	diS	diS	diS	diS	diS	diS	diS
H45	Configuration of analog input 5 type (Pb5). Same as H41.	diS, di, Pro	num	diS	diS	diS	diS	diS	diS	diS	diS	diS
H46	Configuration of analog input 6 type (Pb6 = 4...20 mA). Same as H41.	diS, di, Pro	num	diS	diS	diS	diS	diS	diS	diS	diS	diS
H47	Configuration of analog input 7 type (Pb7). Same as H41.	diS, di, Pro	num	diS	diS	diS	diS	diS	diS	diS	diS	diS
H48	Configuration of analog input 8 type (KDX probe). <ul style="list-style-type: none"> diS (0) = disabled nu (1) = reserved Pro (2) = probe input 	diS, nu, Pro	num	diS	diS	diS	diS	diS	diS	diS	diS	diS
H50	Configuration of analog output type. <ul style="list-style-type: none"> 010 (0) = 0...10 V output 420 (1) = 4...20 mA output 	010/420	flag	010	010	010	010	010	010	010	010	010
H51	Regulator associated with analog output. <ul style="list-style-type: none"> diS (0) = disabled FH (1) = Anti-condensation heaters (Frame Heater) PEr (2) = Valve output opening percentage FAn (3) = Fan modulation 	diS, FH, PEr, FAn	num	diS	diS	diS	diS	diS	diS	diS	diS	diS
H60	Display selected application. <ul style="list-style-type: none"> 0 = disabled 1 = AP1 2 = AP2 3 = AP3 4 = AP4 5 = AP5 6 = AP6 7 = AP7 8 = AP8 	0...8	num	1 (not in applications)								
H68	Configuration of analog input 8 type (KDX probe). <ul style="list-style-type: none"> diS (0) = disabled nu (1) = reserved Pro (2) = probe input 	diS, nu, Pro	num	nu	nu	nu	nu	nu	nu	nu	nu	nu
H70	Sets 1st probe to use as a virtual probe. <ul style="list-style-type: none"> diS (0) = disabled Pb1 (1) = probe Pb1 Pb2 (2) = probe Pb2 Pb3 (3) = probe Pb3 Pb4 (4) = probe Pb4 Pb5 (5) = probe Pb5 	diS, Pb1...Pb5	num	diS	diS	diS	diS	diS	diS	diS	diS	diS
H71	Sets 2nd probe to use as a virtual probe. Same as H70.	diS, Pb1...Pb5	num	diS	diS	diS	diS	diS	diS	diS	diS	diS

PAR	Description	Range	UM	Value	AP1	AP2	AP3	AP4	AP5	AP6	AP7	AP8
H72	% calculation used by the virtual probe for daytime.	0...100	num	50	50	50	50	50	50	50	50	50
H73	% calculation used by the virtual probe for night-time (Energy Saving mode).	0...100	num	50	50	50	50	50	50	50	50	50
H74	Sets the probe used as filtered virtual probe (PFi). <ul style="list-style-type: none"> • diS (0) = disabled • Pb1 (1) = probe Pb1 • Pb2 (2) = probe Pb2 • Pb3 (3) = probe Pb3 • Pb4 (4) = probe Pb4 • Pb5 (5) = probe Pb5 • Pbi (6) = virtual probe 	diS, Pb1...Pb5, Pbi	num	diS	diS	diS	diS	diS	diS	diS	diS	diS
H75	Alpha filter constant to use when calculating the value displayed by the filtered virtual probe (value in thousandths).	1...1000	num	1	1	1	1	1	1	1	1	1
H76	Offset value to use when calculating the value displayed by the filtered virtual probe.	- 999.9...999. 9	num	0.0	0.0	0.0	0.0	0.0	0.0	0.0	0.0	0.0
EE0 (Electronic Expansion Valve)												
Ety	Selects the type of driver for the electronic valve. <ul style="list-style-type: none"> • 0 = disabled • 1 = pulse driver 	0/1	num	1	1	1	1	1	1	1	1	1
rSP	Sets the saturation probe to use. <ul style="list-style-type: none"> • diS (0) = disabled • Pb6 (1) = pressure transducer 4...20 mA • Pb7 (2) = ratiometric transducer • LSP (3) = remote probe (shared within the Link2 network) • rP (4) = remote probe (from supervisor). 	diS, Pb6, Pb7, LSP, rP	num	Pb6 (not in applications)								
rSS	Sets the overheating probe to use. <ul style="list-style-type: none"> • diS (0) = disabled • Pb1 (1) = probe Pb1 • Pb2 (2) = probe Pb2 • Pb3 (3) = probe Pb3 • Pb4 (4) = probe Pb4 • Pb5 (5) = probe Pb5 	diS, Pb1...Pb5	num	Pb5 (not in applications)								
rBU	Sets the saturation probe to use as a backup. <ul style="list-style-type: none"> • diS (0) = disabled • LSP (1) = backup saturation probe • rP (2) = remote probe (from supervisor) 	diS, LSP, rP	num	diS (not in applications)								
EPd	Saturation value display mode. <ul style="list-style-type: none"> • t (0) = temperature • P (1) = pressure 	t/P	flag	t (not in applications)								

PAR	Description	Range	UM	Value	AP1	AP2	AP3	AP4	AP5	AP6	AP7	AP8
Ert	<p>Selects the type of refrigerant used.</p> <ul style="list-style-type: none"> • 404 (0) = R404A • r22 (1) = R22 • 410 (2) = R410A • 134 (3) = R134a • 744(4) = R744 (CO2) • 507 (5) = R507A • 717 (6) = R717 (NH3) • 290 (7) = reserved • 407 (8) = R407A • 448 (9) = R448A • 449 (10) = R449A • 450 (11) = R450 • 513 (12) = R513A • PAr_1 (13) = customizable 1 • PAr_2 (14) = customizable 2 • PAr_3 (15) = customizable 3 • PAr_4 (16) = customizable 4 • PAr_5 (17) = customizable 5 • PAr_6 (18) = customizable 6 <p>Note: For customizations regarding the type of refrigerant used, please contact Eliwell.</p>	404, r22, 410 134, 744, 507, 717, 290, 407, 448, 449 450, 513, PAr_ 1...PAr_6	num	410 (not in applications)								
U02	Maximum valve opening percentage.	0...100	%	100 (not in applications)								
U05	Operating time at maximum opening before an alarm signal.	0...255	min	60 (not in applications)								
U06	Minimum useful valve opening percentage.	0...100	%	10 (not in applications)								
U07	Maximum useful valve opening percentage.	0...100	%	90 (not in applications)								
U08	Sets the fixed opening percentage for the valve if the pressure sensor is not working (U22=diS).	0...100	%	0 (not in applications)								
U13	<p>Indicates the updating frequency for values relating to the thermodynamic cycle of the refrigerated cabinet.</p> <ul style="list-style-type: none"> • if U13 is decreased, updating will be more frequent • if U13 is increased, updating will be less frequent 	0...3600	s	30 (not in applications)								
U14	<p>Sets the overheating control for the thermodynamic cycle of the refrigerated cabinet.</p> <ul style="list-style-type: none"> • if U14 is decreased, the refrigerated cabinet overheating temperature tends towards the value of parameter OLt (Minimum overheating threshold), becoming more reactive • if U14 is increased, the refrigerated cabinet overheating temperature tends to guarantee greater regulation stability than when it approaches parameter OLt (Minimum overheating threshold) <p>OPERATING PROCEDURE</p> <p>To optimize cabinet performance:</p> <ul style="list-style-type: none"> • if the overheating temperature > OLt, decrease U14 • if the overheating temperature < OLt, increase U14 	0.0...500	°C/°F	80.0 (not in applications)								
OLt	Minimum overheating threshold.	0.0...999.9	°C/°F	5.0 (not in applications)								
U20	Continuous modulation differential gain.	0.0...999.9	°C/°F	100 (not in applications)								

PAR	Description	Range	UM	Value	AP1	AP2	AP3	AP4	AP5	AP6	AP7	AP8
U22	Sets the type of controller behavior in the event that the pressure transducer is not working. <ul style="list-style-type: none"> diS (0) = uses a fixed opening percentage set via parameter U08 En (1) = uses the value set via parameter U23 as a backup saturation temperature. 	diS/En	flag	diS (not in applications)								
U23	Sets the saturation temperature backup value in the event that the pressure transducer is not working.	- 999.9...999. 9	°C/°F	0.0 (not in applications)								
U25	Sets the loads to be disabled in the event of a faulty compressor. <ul style="list-style-type: none"> 0 = Disabled 1 = Defrost 2 = Lights 3 = Defrost and lights 4 = Anti-condensation heaters 5 = Defrost and Anti-condensation heaters 6 = Lights and Anti-condensation heaters 7 = Defrost, Lights and Anti-condensation heaters 8 = Evaporator fans 9 = Defrost and Fans 10 = Lights and Fans 11 = Defrost, Lights and Fans 12 = Anti-condensation heaters and Fans 13 = Defrost, Anti-condensation heaters and Fans 14 = Lights, Anti-condensation heaters and Fans 15 = Defrost, Lights, Anti-condensation heaters and Fans 	0...15	num	0 (not in applications)								
U26	Sets the saturation temperature threshold for detecting the faulty compressor in addition to disabling the loads.	- 999.9...999. 9	°C/°F	0.0 (not in applications)								
U51	Overheating filter calculation coefficient.	0...999	num	10 (not in applications)								
HOE	Enable MOP <ul style="list-style-type: none"> 0 = disabled 1 = enabled 	0/1	flag	0 (not in applications)								
tAP	Minimum time maximum temperature threshold for alarm activation exceeded.	0...255	min	180 (not in applications)								
Hot	Maximum evaporator temperature threshold.	- 999.9...999. 9	°C/°F	0.0 (not in applications)								
HdP	MOP disable duration at startup.	0...999	min	0 (not in applications)								
A_F	Select PID automatic or manual mode	0/1	num	0 (not in applications)								
dUt	PID duty cycle in manual mode.	0...100	%	0 (not in applications)								
FPr (UNICARD)												
UL	Transfer of the programming parameters from the controller to the UNICARD/MFK.	/	/	/ (not in applications)								
dL	Transfer of the programming parameters from the UNICARD/MFK to the controller.	/	/	/ (not in applications)								
Fr	UNICARD formatting. Deletes all data on the UNICARD. Note: the use of parameter Fr results in the loss of all data entered. This operation cannot be reversed.	/	/	/ (not in applications)								
FnC (Functions) - Note : If the device is switched off the function labels will revert to default status (inactive). To change their status, press the "set" key												

PAR	Description	Range	UM	Value	AP1	AP2	AP3	AP4	AP5	AP6	AP7	AP8
dEF	Manual defrost activation. <ul style="list-style-type: none"> Function active: dEF label and flashing icon Function inactive: dEF label Indication: Defrost icon flashing 	/	/	/(not in applications)								
AUX	Manual auxiliary output activation. <ul style="list-style-type: none"> Function active: Aon label Function inactive: AoF label Indication: AUX icon steadily lit 	/	/	/(not in applications)								
Stand-by	Manual stand-by activation. <ul style="list-style-type: none"> Function active: ON label Function inactive: OFF label Indication: Stand-by LED lit steadily (only KDWPlus) 	/	/	/(not in applications)								
OiL (Compressor oil heater)												
OHP	Sets the regulation probe used by the compressor oil heater. <ul style="list-style-type: none"> diS (0) = disabled Pb1 (1) = probe Pb1 Pb2 (2) = probe Pb2 Pb3 (3) = probe Pb3 Pb4 (4) = probe Pb4 Pb5 (5) = probe Pb5 Pbi (6) = virtual probe LP (7) = remote probe Pfi (8) = filtered virtual probe 	diS, Pb1...Pb5, Pbi, LP, Pfi	num	diS	diS	diS	diS	diS	diS	diS	diS	diS
OSP	Sets the regulation setpoint used by the compressor oil heater.	OLS...OHS	°C/°F	1.0	1.0	1.0	1.0	1.0	1.0	1.0	1.0	1.0
OHd	Sets the regulation differential used by the compressor oil heater.	0.1...25.0	°C/°F	0.1	0.1	0.1	0.1	0.1	0.1	0.1	0.1	0.1
OHS	Maximum value that can be set for the compressor oil heater setpoint.	OLS...302	°C/°F	30.0	30.0	30.0	30.0	30.0	30.0	30.0	30.0	30.0
OLS	Minimum value that can be set for the compressor oil heater setpoint.	-58.0...OHS	°C/°F	-10.0	-10.0	-10.0	-10.0	-10.0	-10.0	-10.0	-10.0	-10.0

Note: if one or more parameters in the folder **CnF** are changed, switch the controller off and on again.

Modbus MSK 756 functions and resources

Contents

This section includes the following topics:

Setting parameters via Modbus	194
Modbus table content	195
Table of Modbus Parameters	197
Folder Visibility Table	297
Table of Modbus Resources	301

Setting parameters via Modbus

Introduction

Modbus is a client/server protocol for communication between devices connected in a network. Modbus devices communicate using a master-slave technique in which only one device (master) can send messages. The other devices in the network (slave) respond, returning the data requested by the master or executing the action contained in the message sent. A slave is a device connected to a network that processes information and sends the results to the master using the Modbus protocol.

The master device can send messages to individual slaves, or to the entire network (broadcast), whilst slave devices can only respond to messages individually and to the master device. The Modbus standard used by Eliwell employs the RTU code for data transmission.

Data format (RTU)

The coding type used defines the structure of messages transmitted on the network and the way in which this information is deciphered. The coding type is usually chosen according to specific parameters (baudrate, parity, stop), plus certain devices only support specific coding types. Use the same coding type for all devices connected to a Modbus network.

The protocol uses the RTU binary method with the serial frame configured as follows:

- 8 bits for data
- parity bits NONE (configurable)

Parameters can be changed via:

- Device terminal
- UNICARD / DMI
- Send data via Modbus protocol directly to an individual device or in a broadcast using the address 0 (broadcast)

Modbus commands available and data areas

The following commands are implemented:

Modbus command	Description
03 (hex 0x03)	Read resources
16 (hex 0x10)	Write resources
43 (hex 0x2B)	Read device ID. The following 3 fields can be read: <ul style="list-style-type: none"> • 0 = Manufacturer ID • 1 = Model ID • 2 = Family ID (MSK 755) / device version

Note: Maximum length of transmitted/received messages equal to 50 bytes.

Address configuration

The **TTL** serial port may be used to configure the device, parameters, statuses, variables with Modbus using the Modbus protocol.

The address of a device within a Modbus message is set via parameter **Adr**.

The address **0** is used for broadcast messages that all slaves recognize. Slaves do not respond to a broadcast type request.

The device configuration parameters are as follows:

Parameter	Description
Adr	Modbus protocol controller address
bAU	Baudrate selection
Pty	Sets the Modbus protocol parity BIT. <ul style="list-style-type: none"> • n = parity bit NONE • E = parity bit EVEN • o = parity bit ODD

Note: Switch the controller off and on again after changing **Pty**.

Parameter values and visibility

Below are several notes relating to the value and visibility of the parameters.

Notes:

- Unless otherwise indicated, the parameter should be considered as visible and able to be changed unless the user applies custom settings via the serial port.
- If the visibility of the folder is changed all the parameters in that folder will assume the new setting.

Modbus table content

Introduction

The tables below contain the information required to access the resources properly.

There are 3 tables:

- **Modbus Parameters Table:** contains all the device configuration parameters including visibility
- **Folder Visibility Table:** contains the visibility of the folders containing the parameters
- **Modbus Resource Table:** contains all status (I/O) and alarm resources available in the volatile memory of the device.

Description of the columns

FOLDER

Indicates the name of the folder containing the parameter in question.

LABEL

Indicates the name with which the parameter appears in the menu.

DESCRIPTION

Description of the parameter's meaning.

PAR. ADDRESS VAL.

Represents the Modbus register address which contains the read or write value of the resource in the device.

FILTER VAL.

Represents the position of the most significant data bit inside the register. This information is always provided when the register contains more than one piece of information and it is necessary to distinguish which bits actually represent the data (the useful size of the data, indicated in the DATA SIZE column, should also be taken into account).

PAR. ADDRESS VIS.

Contains the Modbus register address which contains the visibility value of the resource to read or write in the device.

FILTER VIS.

Mask representing the position of the data inside the register (it has BITS set to 1 in correspondence with the register BITS effectively associated with the resource). It assumes values from 0 to 65535.

Note: in binary representation the least significant is furthest to the right.

Visibility:

- Value **3** = parameter or folder always visible
- Value **2** = manufacturer level; these parameters and folders are only visible when the manufacturer password (**PS2**) is entered (with this password you will be able to see all parameters declared as always visible; level **1** parameters will not be visible)
- Value **1** = installer level; these parameters and folders are only visible when the installer password (**PS1**) is entered (with this password you will be able to see all parameters declared as always visible; level **2** parameters will not be visible)
- Value **0** = parameter or folder NOT visible

Note: the size of the piece of visibility data is 2 BIT.

R/W

Indicates the option of reading or writing the resource:

- R = the resource is read-only
- W = the resource is write-only
- R/W = the resource can be both read and written

DATA SIZE

Indicates the size of the piece of data (in bit):

- WORD = 16 bit
- Byte = 8 bit
- "n" bit = 0...15 bit based on the value of "n"

CPL

When the field indicates **Y**, the value read by the register needs to be converted because the value represents a number with a sign. In the other cases the value is always positive or null.

To convert it, proceed as follows:

If the register value falls between...	Then the result is...
0 and 32767	the same value (zero and positive values).
32768 and 65535	the register value, from which to subtract 65536 (negative values).

RANGE

Describes the interval of values that can be assigned to the parameter. This range can be correlated to the value of other parameters.

MU

Unit of measure for the values.

Table of Modbus Parameters

Folders	Label	Description	Val. Par. Address	Val. Filter	Vis. Par. Address	Vis. Filter	R/W	Date Size	CPL	Range	MU
CP	rE	Regulation type	32892	0	38144	3	RW	Word		0...6	num
CP	rP1	Thermostat regulation probe 1	32893	0	38144	12	RW	Word		0...8	num
CP	rP2	Thermostat regulation probe 2	32894	0	38144	48	RW	Word		0...9	num
CP	SP1	Regulation setpoint 1	32895	0	38144	192	RW	Word	Y	LS1...HS1	°C/°F
CP	dF1	Setpoint differential 1	32896	0	38144	768	RW	Word	Y	-58.0...302.0	°C/°F
CP	SP2	Regulation setpoint 2	32897	0	38144	3072	RW	Word	Y	LS2...HS2	°C/°F
CP	dF2	Setpoint differential 2	32898	0	38144	12288	RW	Word	Y	-58.0...302.0	°C/°F
CP	Stt	Differential management mode	32901	0	38144	49152	RW	Word		0...1	num
CP	HS1	Maximum value that can be set for Setpoint 1	32904	0	38145	3	RW	Word	Y	LS1...HdL	°C/°F
CP	LS1	Minimum value that can be set for Setpoint 1	32905	0	38145	12	RW	Word	Y	LdL...HS1	°C/°F
CP	HS2	Maximum value that can be set for Setpoint 2	32906	0	38145	48	RW	Word	Y	LS2...HdL	°C/°F
CP	LS2	Minimum value that can be set for Setpoint 2	32907	0	38145	192	RW	Word	Y	LdL...HS2	°C/°F
CP	HC1	Setpoint 1 operating mode (Heating/Cooling)	32902	0	38145	768	RW	Word		0...1	num
CP	HC2	Setpoint 2 operating mode (Heating/Cooling)	32903	0	38145	3072	RW	Word		0...1	num
CP	Cit	Minimum compressor output activation time	32912	0	38145	49152	RW	Word		0...250	min
CP	CAt	Maximum compressor output activation time	32913	0	38146	3	RW	Word		0...250	min
CP	Ont	Compressor output ON time if regulation probe is faulty	32918	0	38146	12	RW	Word		0...250	min
CP	OFt	Compressor output OFF time if regulation probe is faulty	32919	0	38146	48	RW	Word		0...250	min
CP	dOn	Compressor output activation delay from call	32914	0	38146	192	RW	Word		0...250	s
CP	dOF	Compressor output activation delay from switch-off	32915	0	38146	768	RW	Word		0...250	min
CP	dbi	Delay between two consecutive compressor output power-ons	32916	0	38146	3072	RW	Word		0...250	min
CP	OdO	Output activation delay at startup	32917	0	38146	12288	RW	Word		0...250	min
CP	CFP	Condenser pre-ventilation time in Heat/Cool	33001	0	38147	12	RW	Word		0...255	s
CP	CFd	Condenser fan cut-out during defrosting.	33002	0	38147	48	RW	Word		0...1	num
CP	OF1	Remote offset	32923	0	38147	192	RW	Word	Y	-50.0...50.0	°C/°F
CP	Pot	Pump down time	33029	0	38178	192	RW	Word		0...250	s

Folders	Label	Description	Val. Par. Address	Val. Filter	Vis. Par. Address	Vis. Filter	R/W	Date Size	CPL	Range	MU
CP	SS1	Compressor softstart: advance hotgas valve opening	33030	0	38178	768	RW	Word		0...250	s
CP	SS2	Compressor softstart: delay hotgas valve closing	33031	0	38178	3072	RW	Word		0...250	s
dEF	dP1	Select defrost probe 1	32924	0	38147	768	RW	Word		0...8	num
dEF	dP2	Defrost probe 2 selection	32925	0	38147	3072	RW	Word		0...8	num
dEF	dtY	Type of defrost	32928	0	38147	12288	RW	Word		0...4	num
dEF	dFt	Dual evaporator defrost activation mode	32926	0	38147	49152	RW	Word		0...2	num
dEF	dit	Interval between defrosts	32929	0	38148	3	RW	Word		0...250	h/min/s
dEF	dt1	Unit of measure for defrost intervals	32932	0	38148	12	RW	Word		0...2	num
dEF	dt2	Unit of measure for defrost duration	32933	0	38148	48	RW	Word		0...2	num
dEF	dCt	Defrost interval count mode	32927	0	38148	192	RW	Word		0...5	num
dEF	dOH	Defrost cycle activation delay from the call	32934	0	38148	768	RW	Word		0...250	min
dEF	dE1	Evaporator 1 defrost maximum duration	32930	0	38148	3072	RW	Word		1...250	h/min/s
dEF	dE2	Evaporator 2 defrost maximum duration	32931	0	38148	12288	RW	Word		1...250	h/min/s
dEF	dS1	Evaporator 1 defrost end temperature	32936	0	38148	49152	RW	Word	Y	-58.0...302.0	°C/°F
dEF	dS2	Evaporator 2 defrost end temperature	32937	0	38149	3	RW	Word	Y	-58.0...302.0	°C/°F
dEF	dSS	Temperature threshold for starting defrost	32935	0	38149	12	RW	Word	Y	-58.0...302.0	°C/°F
dEF	dPO	Defrost activation request at power-on	32938	0	38149	48	RW	Word		0...1	num
dEF	tcd	Compressor output activation/deactivation time before a defrost	32939	0	38149	192	RW	Word	Y	-60...60	min
dEF	ndE	minimum defrost duration time	32940	0	38149	768	RW	Word		0...250	h/min/s
dEF	PdC	Hot gas extraction time at the end of the defrost	32941	0	38149	3072	RW	Word		0...250	min
dEF	tPd	Pump down time before defrost start	32943	0	38149	12288	RW	Word		0...255	min
dEF	dPH	Regular defrost start hour	32882	0	38149	49152	RW	Word		0...24	h
dEF	dPn	Regular defrost start minutes	32883	0	38150	3	RW	Word		0...59	min
dEF	dPd	Regular defrost interval duration	32884	0	38150	12	RW	Word		1...7	day
dEF	Fd1	1st weekend/holiday day	32831	0	38150	48	RW	Word		0...7	num
dEF	Fd2	2nd weekend/holiday day	32832	0	38150	192	RW	Word		0...7	num
dEF	Edt	Timeout and defrost end temperature specific to each event	32833	0	38150	768	RW	Word		0...1	num

Folders	Label	Description	Val. Par. Address	Val. Filter	Vis. Par. Address	Vis. Filter	R/W	Date Size	CPL	Range	MU
dEF	PrH	Basin heater pre-activation time	33038	0	38179	3072	RW	Word		0...255	min
dEF	Fdn	Weekday defrost number	32781	0	38184	3	RW	Word		0...250	num
dEF	FFn	Weekend/holiday defrost number	32782	0	38184	12	RW	Word		0...250	num
dEF	d1H	Weekday defrost no. 1 start hour	32834	0	38150	3072	RW	Word		0...24	h
dEF	d1n	Weekday defrost no. 1 start minute	32835	0	38150	12288	RW	Word		0...59	min
dEF	d1t	1st weekday defrost duration	32836	0	38150	49152	RW	Word		0...250	min
dEF	d1S	1st weekday defrost end temperature	32837	0	38151	3	RW	Word	Y	-58.0...302.0	°C/°F
dEF	d2H	Weekday defrost no. 2 start hour	32838	0	38151	12	RW	Word		d1H...24	h
dEF	d2n	Weekday defrost no. 2 start minutes	32839	0	38151	48	RW	Word		0...59	min
dEF	d2t	2nd weekday defrost duration	32840	0	38151	192	RW	Word		0...250	min
dEF	d2S	2nd weekday defrost end temperature	32841	0	38151	768	RW	Word	Y	-58.0...302.0	°C/°F
dEF	d3H	Weekday defrost no. 3 start hour	32842	0	38151	3072	RW	Word		d2H...24	h
dEF	d3n	Weekday defrost no. 3 start minutes	32843	0	38151	12288	RW	Word		0...59	min
dEF	d3t	3rd weekday defrost duration	32844	0	38151	49152	RW	Word		0...250	min
dEF	d3S	3rd weekday defrost end temperature	32845	0	38152	3	RW	Word	Y	-58.0...302.0	°C/°F
dEF	d4H	Weekday defrost no. 4 start hour	32846	0	38152	12	RW	Word		d3H...24	h
dEF	d4n	Weekday defrost no. 4 start minutes	32847	0	38152	48	RW	Word		0...59	min
dEF	d4t	4th weekday defrost duration	32848	0	38152	192	RW	Word		0...250	min
dEF	d4S	4th weekday defrost end temperature	32849	0	38152	768	RW	Word	Y	-58.0...302.0	°C/°F
dEF	d5H	Weekday defrost no. 5 start hour	32850	0	38152	3072	RW	Word		d4H...24	h
dEF	d5n	Weekday defrost no. 5 start minutes	32851	0	38152	12288	RW	Word		0...59	min
dEF	d5t	5th weekday defrost duration	32852	0	38152	49152	RW	Word		0...250	min
dEF	d5S	5th weekday defrost end temperature	32853	0	38153	3	RW	Word	Y	-58.0...302.0	°C/°F
dEF	d6H	Weekday defrost no. 6 start hour	32854	0	38153	12	RW	Word		d5H...24	h
dEF	d6n	Weekday defrost no. 6 start minutes	32855	0	38153	48	RW	Word		0...59	min
dEF	d6t	6th weekday defrost duration	32856	0	38153	192	RW	Word		0...250	min
dEF	d6S	6th weekday defrost end temperature	32857	0	38153	768	RW	Word	Y	-58.0...302.0	°C/°F
dEF	F1H	Weekend/holiday defrost no. 1 start hour	32858	0	38153	3072	RW	Word		0...24	h
dEF	F1n	Weekend/holiday defrost no. 1 start minute	32859	0	38153	12288	RW	Word		0...59	min

Folders	Label	Description	Val. Par. Address	Val. Filter	Vis. Par. Address	Vis. Filter	R/W	Date Size	CPL	Range	MU
dEF	F1t	1st weekend/holiday defrost duration	32860	0	38153	49152	RW	Word		0...250	min
dEF	F1S	1st weekend/holiday defrost end temperature	32861	0	38154	3	RW	Word	Y	-58.0...302.0	°C/°F
dEF	F2H	Weekend/holiday defrost no. 2 start hour	32862	0	38154	12	RW	Word		F1H...24	h
dEF	F2n	Weekend/holiday defrost no. 2 start minutes	32863	0	38154	48	RW	Word		0...59	min
dEF	F2t	2nd weekend/holiday defrost duration	32864	0	38154	192	RW	Word		0...250	min
dEF	F2S	2nd weekend/holiday defrost end temperature	32865	0	38154	768	RW	Word	Y	-58.0...302.0	°C/°F
dEF	F3H	Weekend/holiday defrost no. 3 start hour	32866	0	38154	3072	RW	Word		F2H...24	h
dEF	F3n	Weekend/holiday defrost no. 3 start minutes	32867	0	38154	12288	RW	Word		0...59	min
dEF	F3t	3rd weekend/holiday defrost duration	32868	0	38154	49152	RW	Word		0...250	min
dEF	F3S	3rd weekend/holiday defrost end temperature	32869	0	38155	3	RW	Word	Y	-58.0...302.0	°C/°F
dEF	F4H	Weekend/holiday defrost no. 4 start hour	32870	0	38155	12	RW	Word		F3H...24	h
dEF	F4n	Weekend/holiday defrost no. 4 start minutes	32871	0	38155	48	RW	Word		0...59	min
dEF	F4t	4th weekend/holiday defrost duration	32872	0	38155	192	RW	Word		0...250	min
dEF	F4S	4th weekend/holiday defrost end temperature	32873	0	38155	768	RW	Word	Y	-58.0...302.0	°C/°F
dEF	F5H	Weekend/holiday defrost no. 5 start hour	32874	0	38155	3072	RW	Word		F4H...24	h
dEF	F5n	Weekend/holiday defrost no. 5 start minutes	32875	0	38155	12288	RW	Word		0...59	min
dEF	F5t	5th weekend/holiday defrost duration	32876	0	38155	49152	RW	Word		0...250	min
dEF	F5S	5th weekend/holiday defrost end temperature	32877	0	38156	3	RW	Word	Y	-58.0...302.0	°C/°F
dEF	F6H	Weekend/holiday defrost no. 6 start hour	32878	0	38156	12	RW	Word		F5H...24	h
dEF	F6n	Weekend/holiday defrost no. 6 start minutes	32879	0	38156	48	RW	Word		0...59	min
dEF	F6t	6th weekend/holiday defrost duration	32880	0	38156	192	RW	Word		0...250	min
dEF	F6S	6th weekend/holiday defrost end temperature	32881	0	38156	768	RW	Word	Y	-58.0...302.0	°C/°F
Fan	FP1	Selection of evaporator fan probe in normal mode	32944	0	38156	3072	RW	Word		0...8	num

Folders	Label	Description	Val. Par. Address	Val. Filter	Vis. Par. Address	Vis. Filter	R/W	Date Size	CPL	Range	MU
Fan	FP2	Selection of evaporator fan probe in defrost	32945	0	38156	12288	RW	Word		0...8	num
Fan	FPt	FSt parameter mode (absolute or relative)	32946	0	38156	49152	RW	Word		0...1	num
Fan	FSt	Evaporator fan disabling temperature	32947	0	38157	3	RW	Word	Y	-58.0...302.0	°C/°F
Fan	FAd	Evaporator fan trigger differential	32948	0	38157	12	RW	Word		0.1...25.0	°C/°F
Fan	Fdt	Evaporator fan activation delay time after a defrost cycle	32949	0	38157	48	RW	Word		0...250	min
Fan	dt	Dripping time	32954	0	38157	192	RW	Word		0...250	min
Fan	dFd	Evaporator fan cut-out during defrost	32952	0	38157	768	RW	Word		0...1	num
Fan	FCO	Evaporator fan status with compressor output Off	32951	0	38157	3072	RW	Word		0...4	num
Fan	Fod	Evaporator fan status with door open	32953	0	38157	12288	RW	Word		0...1	num
Fan	FdC	Evaporator fan shutoff delay after compressor deactivation	32950	0	38157	49152	RW	Word		0...250	min
Fan	FOn	Evaporator fan On time in cyclical regulator mode	32955	0	38158	3	RW	Word		0...250	min
Fan	FOF	Evaporator fan Off time in cyclical regulator mode	32956	0	38158	12	RW	Word		0...250	min
Fan	Fnn	Evaporator fan ON time in night mode (duty cycle)	32957	0	38158	48	RW	Word		0...250	min
Fan	FnF	Evaporator fan OFF time in night mode (duty cycle)	32958	0	38158	192	RW	Word		0...250	min
FE	FE1	Variable speed fan probe selection	33057	0	38182	48	RW	Word		0...12	num
FE	FEt	Setpoint mode	33058	0	38182	192	RW	Word		0...1	num
FE	FES	Setpoint	33059	0	38182	768	RW	Word	Y	-58...302	num
FE	FEd	Band	33060	0	38182	3072	RW	Word		0.1...50	num
FE	FEu	Cut-off band	33061	0	38182	12288	RW	Word		0...25	num
FE	FEC	Cut-off differential	33062	0	38182	49152	RW	Word		0.1...25	num
FE	FEr	Fan shutoff delay after compressor deactivation	33063	0	38183	3	RW	Word		0...250	min
FE	FE2	Minimum day percentage	33064	0	38183	12	RW	Word		0...100	%
FE	FE3	Maximum day percentage with compressor on	33065	0	38183	48	RW	Word		0...100	%
FE	FE4	Maximum day percentage with compressor off	33066	0	38183	192	RW	Word		0...100	%
FE	FE5	Minimum night percentage	33067	0	38183	768	RW	Word		0...100	%
FE	FE6	Maximum night percentage with compressor on	33068	0	38183	3072	RW	Word		0...100	%

Folders	Label	Description	Val. Par. Address	Val. Filter	Vis. Par. Address	Vis. Filter	R/W	Date Size	CPL	Range	MU
FE	FE7	Maximum night percentage with compressor off	33069	0	38183	12288	RW	Word		0...100	%
FE	FE8	Percentage during defrost	33070	0	38183	49152	RW	Word		0...100	%
FE	FE9	Percentage in the event of probe error	33071	0	38195	12	RW	Word		0...100	%
FE	FEA	Maximum pick-up speed	33072	0	38195	48	RW	Word		0...100	%
FE	FEb	Fan pick-up time	33073	0	38195	192	RW	Word		0...250	s
FE	FEP	Fan forcing period at pick-up speed	33074	0	38195	768	RW	Word		0...250	min
AL	rA1	Temperature alarm probe 1 selection	32972	0	38158	768	RW	Word		0...7	num
AL	rA2	Temperature alarm probe 2 selection	32973	0	38158	3072	RW	Word		0...7	num
AL	Att	Alarm mode (absolute or relative)	32974	0	38158	12288	RW	Word		0...1	num
AL	AFd	Alarm activation differential	32975	0	38158	49152	RW	Word		0.1...25.0	°C/°F
AL	HA1	Maximum alarm 1 threshold	32976	0	38159	3	RW	Word	Y	LA1...302.0	°C/°F
AL	LA1	Minimum alarm 1 threshold	32977	0	38159	12	RW	Word	Y	-58.0...HA1	°C/°F
AL	HA2	Maximum alarm 2 threshold	32978	0	38159	48	RW	Word	Y	LA2...302.0	°C/°F
AL	LA2	Minimum alarm 2 threshold	32979	0	38159	192	RW	Word	Y	-58.0...HA2	°C/°F
AL	PAO	Temperature alarm exclusion time from power-on	32980	0	38159	768	RW	Word		0...10	h
AL	dAO	Exclusion time for temperature alarms after a defrost cycle	32982	0	38159	3072	RW	Word		0...250	min
AL	OAO	High and low temperature alarms exclusion time after closing the door	32981	0	38159	12288	RW	Word		0...10	h
AL	tdO	Door open alarm exclusion time	33026	0	38159	49152	RW	Word		0...250	min
AL	tA1	Probe 1 High/Minimum Alarm Delay	32983	0	38160	3	RW	Word		0...250	min
AL	tA2	Probe 2 High/Minimum Alarm Delay	32984	0	38160	12	RW	Word		0...250	min
AL	dAt	Defrost ended due to timeout alarm signaling	32942	0	38160	48	RW	Word		0...1	num
AL	EAL	Regulators inhibited by external alarm	32986	0	38160	192	RW	Word		0...2	num
AL	rA3	Leak detection probe selection	33045	0	38180	12288	RW	Word		0...8	num
AL	ALL	Low threshold leak alarm	33046	0	38180	49152	RW	Word		0...ALH	num
AL	ALH	High threshold leak alarm	33047	0	38181	3	RW	Word		ALL...100	num
AL	dAL	Alarm leak differential	33048	0	38181	12	RW	Word		0.1...100	num

Folders	Label	Description	Val. Par. Address	Val. Filter	Vis. Par. Address	Vis. Filter	R/W	Date Size	CPL	Range	MU
AL	AL1	Time probe remains above the low threshold due to leak alarm activation	33049	0	38181	48	RW	Word		0...250	min
AL	AL2	Time probe remains above the high threshold due to leak alarm activation	33056	0	38182	12	RW	Word		0...250	min
AL	tP	Enables alarm acknowledgment with any key	33027	0	38160	768	RW	Word		0...1	min
AL	Art	Regular watchdog alarm activation period	32971	0	38160	3072	RW	Word		0...250	min*10
Lit	dSd	Enable light relay from door switch	32968	0	38160	12288	RW	Word		0...1	num
Lit	dLt	Light relay off delay from door closure	32969	0	38160	49152	RW	Word		0...250	min
Lit	OFL	Enable cold room lights off via key during the delay set in parameter dLt	32970	0	38161	3	RW	Word		0...1	num
Lit	dOd	Enable utility shutoff upon door switch activation	32985	0	38161	12	RW	Word		0...3	num
Lit	dOA	Behavior forced by digital input	32987	0	38161	48	RW	Word		0...5	num
Lit	PEA	Enable forced behavior from door switch and/or external alarm.	32988	0	38161	192	RW	Word		0...3	num
Lit	dCO	Compressor activation delay from acknowledgment	32989	0	38161	768	RW	Word		0...250	min
Lit	dFO	Fan enabling delay from acknowledgment	32990	0	38161	3072	RW	Word		0...250	min
Lit	ASb	Instrument off active light/auxiliary digital input or key	33016	0	38161	12288	RW	Word		0...1	num
Lin	L00	Shared probe	32768	0	38161	49152	RW	Word		0...7	num
Lin	L01	Distributed viewing (refers to slave)	32769	0	38162	3	RW	Word		0...2	num
Lin	L02	Setpoint synchronization	32770	0	38162	12	RW	Word		0...1	num
Lin	L03	Defrost synchronization	32771	0	38162	48	RW	Word		0...2	num
Lin	L04	Inhibit resources at the end of defrost	32772	0	38162	192	RW	Word		0...1	num
Lin	L05	Stand-by synchronization	32773	0	38162	768	RW	Word		0...1	num
Lin	L06	Lights synchronization	32774	0	38162	3072	RW	Word		0...1	num
Lin	L07	Reduced set synchronization	32775	0	38162	12288	RW	Word		0...1	num
Lin	L08	AUX synchronization	32776	0	38162	49152	RW	Word		0...1	num
Lin	L09	Shared saturation probe	32777	0	38163	3	RW	Word		0...1	num
Lin	L10	Resource unlocking timeout during synchronized defrosts	33028	0	38163	12	RW	Word		0...250	min
Lin	L11	Number of devices connected in Link2	32778	0	38180	48	RW	Word		0...8	num

Folders	Label	Description	Val. Par. Address	Val. Filter	Vis. Par. Address	Vis. Filter	R/W	Date Size	CPL	Range	MU
Lin	L12	Alarm relay sharing in Link2	32779	0	38180	192	RW	Word		0...2	num
Lin	L13	Link2 serial frame configuration	33039	0	38179	12288	RW	Word		0...1	num
Lin	L14	Force cool mode	33055	0	38182	3	RW	Word		0...1	num
dEC	dcS	Deep cooling setpoint	32962	0	38163	768	RW	Word	Y	-58.0...302.0	°C/°F
dEC	tdc	Deep cooling duration	32963	0	38163	3072	RW	Word		0...250	min
dEC	dcc	Defrost delay after deep cooling	32964	0	38163	12288	RW	Word		0...250	min
EnS	ESt	Type of action for the Energy Saving function	32891	0	38163	49152	RW	Word		0...8	num
EnS	ESF	Night mode activation (Energy Saving)	32959	0	38164	3	RW	Word		0...1	num
EnS	Cdt	Door closing time	32960	0	38164	12	RW	Word		0...255	min*10
EnS	ESo	Low consumption mode disabling timeout (door switch)	32961	0	38164	48	RW	Word		0...10	num
EnS	OS1	Offset on setpoint 1	32908	0	38164	192	RW	Word	Y	-50.0...50.0	°C/°F
EnS	OS2	Offset on setpoint 2	32909	0	38164	768	RW	Word	Y	-50.0...50.0	°C/°F
EnS	Od1	Refrigerated cabinets energy saving offset 1	32910	0	38164	3072	RW	Word	Y	-50.0...50.0	°C/°F
EnS	Od2	Refrigerated cabinets energy saving offset 2	32911	0	38164	12288	RW	Word	Y	-50.0...50.0	°C/°F
EnS	dn1	Differential during energy saving mode 1	32899	0	38164	49152	RW	Word	Y	-58.0...302.0	°C/°F
EnS	dn2	Differential during energy saving mode 2	32900	0	38165	3	RW	Word	Y	-58.0...302.0	°C/°F
EnS	EdH	Weekday energy saving start hour	32885	0	38165	12	RW	Word		0...24	h
EnS	Edn	Weekday energy saving start minutes	32886	0	38165	48	RW	Word		0...59	min
EnS	Edd	Weekday energy saving duration	32887	0	38165	192	RW	Word		1...72	h
EnS	EFH	Weekend/holiday energy saving start hour	32888	0	38165	768	RW	Word		0...24	h
EnS	EFn	Weekend/holiday energy saving start minutes	32889	0	38165	3072	RW	Word		0...59	min
EnS	EFd	Weekend/holiday energy saving duration	32890	0	38165	12288	RW	Word		1...72	h
FrH	FH	Frame heater probe selection	32991	0	38165	49152	RW	Word		0...9	num
FrH	FHt	Frame heater period	32993	0	38166	3	RW	Word		1...250	s*10
FrH	FH0	Frame heater set	32994	0	38166	12	RW	Word	Y	-58.0...302.0	°C/°F
FrH	FH1	Frame heater offset	32995	0	38166	48	RW	Word		0...25.0	°C/°F
FrH	FH2	Frame heater band	32996	0	38166	192	RW	Word	Y	-58.0...302.0	°C/°F
FrH	FH3	Frame heater minimum percentage/duty-cycle	32997	0	38166	768	RW	Word		0...100	%
FrH	FH4	Frame heater maximum percentage/day duty-cycle	32998	0	38166	3072	RW	Word		0...100	%
FrH	FH5	Frame heater maximum percentage/night duty-cycle	32999	0	38166	12288	RW	Word		0...100	%

Folders	Label	Description	Val. Par. Address	Val. Filter	Vis. Par. Address	Vis. Filter	R/W	Date Size	CPL	Range	MU
FrH	FH6	Frame heater percentage/duty-cycle in defrost	33000	0	38166	49152	RW	Word		0...100	%
Add	Adr	Modbus protocol controller address	33157	0	38241	48	RW	Word		1...250	num
Add	bAU	Baudrate selection	33152	0	38241	192	RW	Word		0...2	num
Add	PtY	MODBUS parity bit	33154	0	38241	768	RW	Word		0...2	num
diS	LOC	Disable terminal	33003	0	38167	3	RW	Word		0...1	num
diS	PS1	Password 1 value	33004	0	38167	12	RW	Word		0...250	num
diS	PS2	Password 2 value	33005	0	38167	48	RW	Word		0...250	num
diS	ndt	Display with decimal point	33006	0	38167	192	RW	Word		0...1	num
diS	CA1	Analog input 1 calibration	32812	0	38167	768	RW	Word	Y	-30.0...30.0	°C/°F
diS	CA2	Analog input 2 calibration	32813	0	38167	3072	RW	Word	Y	-30.0...30.0	°C/°F
diS	CA3	Analog input 3 calibration	32814	0	38167	12288	RW	Word	Y	-30.0...30.0	°C/°F
diS	CA4	Analog input 4 calibration	32815	0	38167	49152	RW	Word	Y	-30.0...30.0	°C/°F
diS	CA5	Analog input 5 calibration	32816	0	38168	3	RW	Word	Y	-30.0...30.0	°C/°F
diS	CA6	Analog input 6 calibration	32817	0	38168	12	RW	Word	Y	-30...30	bar/psi
diS	CA7	Analog input 7 calibration	32818	0	38168	48	RW	Word	Y	-30...30	bar/psi
diS	LdL	Minimum display value	33007	0	38168	192	RW	Word	Y	-58.0...HdL	°C/°F
diS	HdL	Maximum display value	33008	0	38168	768	RW	Word	Y	LdL...302.0	°C/°F
diS	ddL	Display lock mode during a defrost	33009	0	38168	3072	RW	Word		0...2	num
diS	Ldd	Display lock timeout from end of defrost	33010	0	38168	12288	RW	Word		0...250	min
diS	dro	Select °C / °F	33011	0	38168	49152	RW	Word		0...1	num
diS	SbP	Pressure unit of measure	33012	0	38169	3	RW	Word		0...1	num
diS	rEP	Displayed pressure relative or absolute	33170	0	38250	3	RW	Word		0...1	num
diS	ddd	Select main display value	33013	0	38169	12	RW	Word		0...8	num
diS	ddE	Resource displayed on ECHO	33014	0	38169	48	RW	Word		0...9	num
HCP	rPH	Select HACCP probe	32965	0	38169	192	RW	Word		0...5	num
CnF	TrA	Select ratiometric probe type	33163	0	38241	3072	RW	Word		0...8	num
CnF	H00	Select analog input type NTC/PTC	32780	0	38169	768	RW	Word		0...2	num
CnF	H02	Function activation time from terminal	33015	0	38169	3072	RW	Word		0...250	s
CnF	H03	Current input lower limit	33164	0	38241	12288	RW	Word	Y	-1...H04	bar
CnF	H04	Current input upper limit	33165	0	38241	49152	RW	Word	Y	H03...150	bar
CnF	H05	Ratiometric probe lower limit	33166	0	38242	3	RW	Word	Y	-1...H06	bar
CnF	H06	Ratiometric probe upper limit	33167	0	38242	12	RW	Word	Y	H05...150	bar
CnF	08L	Analog input 8 lower limit	33195	0	38250	49152	RW	Word		0...08H	num

Folders	Label	Description	Val. Par. Address	Val. Filter	Vis. Par. Address	Vis. Filter	R/W	Date Size	CPL	Range	MU
CnF	08H	Analog input 8 upper limit	33196	0	38251	3	RW	Word		08L...100	num
CnF	H08	Stand-by operating mode	33017	0	38169	12288	RW	Word		0...2	num
CnF	H11	Digital input 1 configurability and polarity	32783	0	38169	49152	RW	Word	Y	-18...18	num
CnF	H12	Digital input 2 configurability and polarity	32784	0	38170	3	RW	Word	Y	-18...18	num
CnF	H13	Digital input 3 configurability and polarity	32785	0	38170	12	RW	Word	Y	-18...18	num
CnF	H14	Digital input 4 configurability and polarity	32786	0	38170	48	RW	Word	Y	-18...18	num
CnF	H15	Digital input 5 configurability and polarity	32787	0	38170	192	RW	Word	Y	-18...18	num
CnF	H16	Digital input 6 configurability and polarity	32788	0	38170	768	RW	Word	Y	-18...18	num
CnF	H17	Digital input 7 configurability and polarity	32789	0	38170	3072	RW	Word	Y	-18...18	num
CnF	H18	Digital input 8 configurability and polarity	32790	0	38170	12288	RW	Word	Y	-18...18	num
CnF	i01	Digital input 9 configurability and polarity	33050	0	38181	192	RW	Word	Y	-18...18	num
CnF	i02	Digital input 10 configurability and polarity	33051	0	38181	768	RW	Word	Y	-18...18	num
CnF	dti	Digital inputs 1 and 2 delay unit of measure	32799	0	38170	49152	RW	Word		0...1	num
CnF	d11	D.I. 1 activation indication delay time	32791	0	38171	3	RW	Word		0...255	min/s
CnF	d12	D.I. 2 activation indication delay time	32792	0	38171	12	RW	Word		0...255	min/s
CnF	d13	D.I. 3 activation indication delay time	32793	0	38171	48	RW	Word		0...255	min
CnF	d14	D.I. 4 activation indication delay time	32794	0	38171	192	RW	Word		0...255	min
CnF	d15	D.I. 5 activation indication delay time	32795	0	38171	768	RW	Word		0...255	min
CnF	d16	D.I. 6 activation indication delay time	32796	0	38171	3072	RW	Word		0...255	min
CnF	d17	D.I. 7 activation indication delay time	32797	0	38171	12288	RW	Word		0...255	min
CnF	d18	D.I. 8 activation indication delay time	32798	0	38171	49152	RW	Word		0...255	min
CnF	01i	D.I. 9 activation indication delay time	33052	0	38181	3072	RW	Word		0...255	min/s
CnF	02i	D.I. 10 activation indication delay time	33053	0	38181	12288	RW	Word		0...255	min
CnF	H21	Configurability of digital output 1	32820	0	38172	3	RW	Word		0...19	num
CnF	H22	Configurability of digital output 2	32821	0	38172	12	RW	Word		0...19	num
CnF	H23	Configurability of digital output 3	32822	0	38172	48	RW	Word		0...19	num

Folders	Label	Description	Val. Par. Address	Val. Filter	Vis. Par. Address	Vis. Filter	R/W	Date Size	CPL	Range	MU
CnF	H24	Configurability of digital output 4	32823	0	38172	192	RW	Word		0...19	num
CnF	H25	Configurability of digital output 5	32824	0	38172	768	RW	Word		0...19	num
CnF	H27	Configurability of digital output 7	32826	0	38172	12288	RW	Word		0...19	num
CnF	H29	Enable buzzer	32827	0	38172	49152	RW	Word		0...1	num
CnF	d01	Configurability of digital output 8	33043	0	38180	768	RW	Word		0...19	num
CnF	d02	Configurability of digital output 9	33044	0	38180	3072	RW	Word		0...19	num
CnF	H31	Configurability of the UP key	33018	0	38173	3	RW	Word		0...9	num
CnF	H32	Configurability of the DOWN key	33019	0	38173	12	RW	Word		0...9	num
CnF	H33	Configurability of the ESC key	33020	0	38173	48	RW	Word		0...9	num
CnF	H34	Configurability of the Free 1 key	33021	0	38173	192	RW	Word		0...9	num
CnF	H35	Configurability of the Free 2 key	33022	0	38173	768	RW	Word		0...9	num
CnF	H36	Configurability of the Free 3 key	33023	0	38173	3072	RW	Word		0...9	num
CnF	H37	Configurability of the Free 4 key	33024	0	38173	12288	RW	Word		0...9	num
CnF	H41	Configuration of analog input 1	32800	0	38173	49152	RW	Word		0...2	num
CnF	H42	Configuration of analog input 2	32801	0	38174	3	RW	Word		0...2	num
CnF	H43	Configuration of analog input 3	32802	0	38174	12	RW	Word		0...2	num
CnF	H44	Configuration of analog input 4	32803	0	38174	48	RW	Word		0...2	num
CnF	H45	Configuration of analog input 5	32804	0	38174	192	RW	Word		0...2	num
CnF	H46	Configuration of analog input 6	32805	0	38174	768	RW	Word		0...2	num
CnF	H47	Configuration of analog input 7	32806	0	38174	3072	RW	Word		0...2	num
CnF	H48	Configuration of analog input 8	33054	0	38181	49152	RW	Word		0...2	num
CnF	H50	Configurability of analog output 1	32828	0	38174	12288	RW	Word		0...1	num
CnF	H51	Function associated with analog output	32829	0	38174	49152	RW	Word		0...3	num
CnF	H60	Parameter vector selector	33158	0	38242	48	R	Word		0...8	num
CnF	H68	RTC present	32830	0	38175	3	RW	Word		0...1	num
CnF	H70	Selection of 1st sensor for virtual probe	32808	0	38175	12	RW	Word		0...5	num
CnF	H71	Selection of 2nd sensor for virtual probe	32809	0	38175	48	RW	Word		0...5	num
CnF	H72	Day virtual probe calculation %	32810	0	38175	192	RW	Word		0...100	%
CnF	H73	Night virtual probe calculation %	32811	0	38175	768	RW	Word		0...100	%
CnF	H74	Selection of 1st sensor for filtered virtual probe	33040	0	38179	49152	RW	Word		0...6	num

Folders	Label	Description	Val. Par. Address	Val. Filter	Vis. Par. Address	Vis. Filter	R/W	Date Size	CPL	Range	MU
CnF	H75	Percentage in thousandths of the incoming signal for filtered virtual probe	33041	0	38180	3	RW	Word		1...1000	num
CnF	H76	Filtered virtual probe offset	33042	0	38180	12	RW	Word	Y	-999.9...999.9	num
EE0	EtY	Selection of electronic expansion valve driver	33025	0	38175	3072	RW	Word		0...1	num
EE0	rSP	Select saturation probe	33280	0	38242	192	RW	Word		0...4	num
EE0	rSS	Select overheating probe	33281	0	38242	768	RW	Word		0...5	num
EE0	rbu	Select backup saturation probe	33282	0	38242	3072	RW	Word		0...2	num
EE0	EPd	View temperature/pressure saturation value	33284	0	38242	12288	RW	Word		0...1	num
EE0	Ert	Select type of refrigerant	33285	0	38242	49152	RW	Word		0...18	num
EE0	U02	Maximum valve opening percentage	33287	0	38243	12	RW	Word		0...100	%
EE0	U05	Operating time at max opening for alarm signaling	33290	0	38243	768	RW	Word		0...255	min
EE0	U06	Minimum useful valve opening percentage	33291	0	38243	3072	RW	Word		0...100	%
EE0	U07	Maximum useful valve opening percentage	33292	0	38243	12288	RW	Word		0...100	%
EE0	U08	Valve opening percentage during probe error	33293	0	38243	49152	RW	Word		0...100	%
EE0	U13	Observation time for parameter recalculation	33296	0	38244	48	RW	Word		0...3600	s
EE0	U14	Overheating minimum transit band	33297	0	38244	192	RW	Word		0...U15	°C
EE0	OLt	Minimum overheating threshold	33302	0	38245	3	RW	Word		0...999.9	°C/°F
EE0	U20	Continuous modulation differential gain	33304	0	38245	48	RW	Word		0...999.9	num
EE0	U22	Enable saturation probe fixed value in case of error	33306	0	38245	768	RW	Word		0...1	num
EE0	U23	Saturation probe fixed value in case of error	33307	0	38245	3072	RW	Word	Y	-999.9...999.9	°C/°F
EE0	U25	Selection of loads to be disabled with faulty compressor	33310	0	38246	3	RW	Word		0...15	%
EE0	U26	Saturation temperature threshold for faulty compressor detection	33311	0	38246	12	RW	Word	Y	-999.9...999.9	°C/°F
EE0	U51	Overheating filter coefficient	33283	0	38246	192	RW	Word		0...999	%
EE0	HOE	Enable MOP	33320	0	38247	48	RW	Word		0...1	flag
EE0	tAP	Min. time max. temp threshold exceeded due to alarm activation	33321	0	38247	192	RW	Word		0...255	min
EE0	Hot	Maximum evaporator temperature threshold	33322	0	38247	768	RW	Word	Y	-999.9...999.9	°C/°F

Folders	Label	Description	Val. Par. Address	Val. Filter	Vis. Par. Address	Vis. Filter	R/W	Date Size	CPL	Range	MU
EE0	HdP	MOP disable duration at startup	33323	0	38247	3072	RW	Word		0...999	min
EE0	A_F	Select PID automatic or manual mode	10287	0	38250	12	RW	Word		0...1	flag
EE0	dUt	PID duty cycle in manual mode	10288	0	38250	48	RW	Word		0...100	%
OiL	OHP	Selection of oil temperature probe	33032	0	38178	12288	RW	Word		0...8	num
OiL	OSP	Oil heater setpoint	33033	0	38178	49152	RW	Word	Y	OLS...OHS	°C/°F
OiL	OHd	Oil heater differential	33034	0	38179	3	RW	Word		0.1...25.0	°C/°F
OiL	OHS	Maximum oil heater setpoint value that can be set	33036	0	38179	48	RW	Word	Y	OLS...302.0	°C/°F
OiL	OLS	Minimum oil heater setpoint value that can be set	33037	0	38179	192	RW	Word	Y	-58.0...OHS	°C/°F
FPr	UL	Visibility of parameter transfer function (Device-> UNICARD/MFK)	-	-	38178	3	RW	Word		0...3	num
FPr	dL	Visibility of parameter transfer function (UNICARD/MFK-> Device)	-	-	38178	12	RW	Word		0...3	num
FPr	Fr	Visibility of UNICARD/MFK formatting function	-	-	38178	48	RW	Word		0...3	num

(*) Parameter only visible at level 2 if dE00 = 0 (custom valve). Parameter visibility cannot be set.

Application 1 parameters											
V1	V1-rE	Regulation type	34428	0	38272	3	RW	Word		0...6	num
V1	V1-rP1	Thermostat regulation probe 1	34429	0	38272	12	RW	Word		0...8	num
V1	V1-rP2	Thermostat regulation probe 2	34430	0	38272	48	RW	Word		0...9	num
V1	V1-SP1	Regulation setpoint 1	34431	0	38272	192	RW	Word	Y	V1-LS1...V1-HS1	°C/°F
V1	V1-dF1	Setpoint differential 1	34432	0	38272	768	RW	Word	Y	-58.0...302.0	°C/°F
V1	V1-SP2	Regulation setpoint 2	34433	0	38272	3072	RW	Word	Y	V1-LS2...V1-HS2	°C/°F
V1	V1-dF2	Setpoint differential 2	34434	0	38272	12288	RW	Word	Y	-58.0...302.0	°C/°F
V1	V1-Stt	Differential management mode	34437	0	38272	49152	RW	Word		0...1	num
V1	V1-HS1	Maximum value that can be set for Setpoint 1	34440	0	38273	3	RW	Word	Y	V1-LS1...V1-HdL	°C/°F
V1	V1-LS1	Minimum value that can be set for Setpoint 1	34441	0	38273	12	RW	Word	Y	V1-LdL...V1-HS1	°C/°F
V1	V1-HS2	Maximum value that can be set for Setpoint 2	34442	0	38273	48	RW	Word	Y	V1-LS2...V1-HdL	°C/°F
V1	V1-LS2	Minimum value that can be set for Setpoint 2	34443	0	38273	192	RW	Word	Y	V1-LdL...V1-HS2	°C/°F
V1	V1-HC1	Setpoint 1 operating mode (Heating/Cooling)	34438	0	38273	768	RW	Word		0...1	num
V1	V1-HC2	Setpoint 2 operating mode (Heating/Cooling)	34439	0	38273	3072	RW	Word		0...1	num
V1	V1-Cit	Minimum compressor output activation time	34448	0	38273	49152	RW	Word		0...250	min

V1	V1-CAt	Maximum compressor output activation time	34449	0	38274	3	RW	Word		0...250	min
V1	V1-Ont	Compressor output ON time if regulation probe is faulty	34454	0	38274	12	RW	Word		0...250	min
V1	V1-OFt	Compressor output OFF time if regulation probe is faulty	34455	0	38274	48	RW	Word		0...250	min
V1	V1-dOn	Compressor output activation delay from call	34450	0	38274	192	RW	Word		0...250	s
V1	V1-dOF	Compressor output activation delay from switch-off	34451	0	38274	768	RW	Word		0...250	min
V1	V1-dbi	Delay between two consecutive compressor output power-ons	34452	0	38274	3072	RW	Word		0...250	min
V1	V1-OdO	Output activation delay at startup	34453	0	38274	12288	RW	Word		0...250	min
V1	V1-CFP	Condenser pre-ventilation time in Heat/Cool	34537	0	38275	12	RW	Word		0...255	s
V1	V1-CFd	Condenser fan cut-out during defrosting.	34538	0	38275	48	RW	Word		0...1	num
V1	V1-OF1	Remote offset	34459	0	38275	192	RW	Word	Y	-50.0...50.0	°C/°F
V1	V1-Pot	Pump down time	34565	0	38306	192	RW	Word		0...250	s
V1	V1-SS1	Compressor softstart: advance hotgas valve opening	34566	0	38306	768	RW	Word		0...250	s
V1	V1-SS2	Compressor softstart: delay hotgas valve closing	34567	0	38306	3072	RW	Word		0...250	s
V1	V1-dP1	Select defrost probe 1	34460	0	38275	768	RW	Word		0...8	num
V1	V1-dP2	Defrost probe 2 selection	34461	0	38275	3072	RW	Word		0...8	num
V1	V1-dtY	Type of defrost	34464	0	38275	12288	RW	Word		0...4	num
V1	V1-dFt	Dual evaporator defrost activation mode	34462	0	38275	49152	RW	Word		0...2	num
V1	V1-dit	Interval between defrosts	34465	0	38276	3	RW	Word		0...250	h/min/s
V1	V1-dt1	Unit of measure for defrost intervals	34468	0	38276	12	RW	Word		0...2	num
V1	V1-dt2	Unit of measure for defrost duration	34469	0	38276	48	RW	Word		0...2	num
V1	V1-dCt	Defrost interval count mode	34463	0	38276	192	RW	Word		0...5	num
V1	V1-dOH	Defrost cycle activation delay from the call	34470	0	38276	768	RW	Word		0...250	min
V1	V1-dE1	Evaporator 1 defrost maximum duration	34466	0	38276	3072	RW	Word		1...250	h/min/s
V1	V1-dE2	Evaporator 2 defrost maximum duration	34467	0	38276	12288	RW	Word		1...250	h/min/s
V1	V1-dS1	Evaporator 1 defrost end temperature	34472	0	38276	49152	RW	Word	Y	-58.0...302.0	°C/°F
V1	V1-dS2	Evaporator 2 defrost end temperature	34473	0	38277	3	RW	Word	Y	-58.0...302.0	°C/°F
V1	V1-dSS	Temperature threshold for starting defrost	34471	0	38277	12	RW	Word	Y	-58.0...302.0	°C/°F

V1	V1-dPO	Defrost activation request at power-on	34474	0	38277	48	RW	Word		0...1	num
V1	V1-tcd	Compressor output activation/deactivation time before a defrost	34475	0	38277	192	RW	Word	Y	-60...60	min
V1	V1-ndE	minimum defrost duration time	34476	0	38277	768	RW	Word		0...250	h/min/s
V1	V1-PdC	Hot gas extraction time at the end of the defrost	34477	0	38277	3072	RW	Word		0...250	min
V1	V1-tPd	Pump down time before defrost start	34479	0	38277	12288	RW	Word		0...255	min
V1	V1-dPH	Regular defrost start hour	34418	0	38277	49152	RW	Word		0...24	h
V1	V1-dPn	Regular defrost start minutes	34419	0	38278	3	RW	Word		0...59	min
V1	V1-dPd	Regular defrost interval duration	34420	0	38278	12	RW	Word		1...7	day
V1	V1-Fd1	1st weekend/holiday day	34367	0	38278	48	RW	Word		0...7	num
V1	V1-Fd2	2nd weekend/holiday day	34368	0	38278	192	RW	Word		0...7	num
V1	V1-Edt	Timeout and defrost end temperature specific to each event	34369	0	38278	768	RW	Word		0...1	num
V1	V1-PrH	Basin heater pre-activation time	34574	0	38307	3072	RW	Word		0...255	min
V1	V1-Fdn	Weekday defrost number	34317	0	38312	3	RW	Word		0...250	num
V1	V1-FFn	Weekend/holiday defrost number	34318	0	38312	12	RW	Word		0...250	num
V1	V1-d1H	Weekday defrost no. 1 start hour	34370	0	38278	3072	RW	Word		0...24	h
V1	V1-d1n	Weekday defrost no. 1 start minute	34371	0	38278	12288	RW	Word		0...59	min
V1	V1-d1t	1st weekday defrost duration	34372	0	38278	49152	RW	Word		0...250	min
V1	V1-d1S	1st weekday defrost end temperature	34373	0	38279	3	RW	Word	Y	-58.0...302.0	°C/°F
V1	V1-d2H	Weekday defrost no. 2 start hour	34374	0	38279	12	RW	Word		V1-d1H...24	h
V1	V1-d2n	Weekday defrost no. 2 start minutes	34375	0	38279	48	RW	Word		0...59	min
V1	V1-d2t	2nd weekday defrost duration	34376	0	38279	192	RW	Word		0...250	min
V1	V1-d2S	2nd weekday defrost end temperature	34377	0	38279	768	RW	Word	Y	-58.0...302.0	°C/°F
V1	V1-d3H	Weekday defrost no. 3 start hour	34378	0	38279	3072	RW	Word		V1-d2H...24	h
V1	V1-d3n	Weekday defrost no. 3 start minutes	34379	0	38279	12288	RW	Word		0...59	min
V1	V1-d3t	3rd weekday defrost duration	34380	0	38279	49152	RW	Word		0...250	min
V1	V1-d3S	3rd weekday defrost end temperature	34381	0	38280	3	RW	Word	Y	-58.0...302.0	°C/°F
V1	V1-d4H	Weekday defrost no. 4 start hour	34382	0	38280	12	RW	Word		V1-d3H...24	h
V1	V1-d4n	Weekday defrost no. 4 start minutes	34383	0	38280	48	RW	Word		0...59	min
V1	V1-d4t	4th weekday defrost duration	34384	0	38280	192	RW	Word		0...250	min

V1	V1-d4S	4th weekday defrost end temperature	34385	0	38280	768	RW	Word	Y	-58.0...302.0	°C/°F
V1	V1-d5H	Weekday defrost no. 5 start hour	34386	0	38280	3072	RW	Word		V1-d4H...24	h
V1	V1-d5n	Weekday defrost no. 5 start minutes	34387	0	38280	12288	RW	Word		0...59	min
V1	V1-d5t	5th weekday defrost duration	34388	0	38280	49152	RW	Word		0...250	min
V1	V1-d5S	5th weekday defrost end temperature	34389	0	38281	3	RW	Word	Y	-58.0...302.0	°C/°F
V1	V1-d6H	Weekday defrost no. 6 start hour	34390	0	38281	12	RW	Word		V1-d5H...24	h
V1	V1-d6n	Weekday defrost no. 6 start minutes	34391	0	38281	48	RW	Word		0...59	min
V1	V1-d6t	6th weekday defrost duration	34392	0	38281	192	RW	Word		0...250	min
V1	V1-d6S	6th weekday defrost end temperature	34393	0	38281	768	RW	Word	Y	-58.0...302.0	°C/°F
V1	V1-F1H	Weekend/holiday defrost no. 1 start hour	34394	0	38281	3072	RW	Word		0...24	h
V1	V1-F1n	Weekend/holiday defrost no. 1 start minute	34395	0	38281	12288	RW	Word		0...59	min
V1	V1-F1t	1st weekend/holiday defrost duration	34396	0	38281	49152	RW	Word		0...250	min
V1	V1-F1S	1st weekend/holiday defrost end temperature	34397	0	38282	3	RW	Word	Y	-58.0...302.0	°C/°F
V1	V1-F2H	Weekend/holiday defrost no. 2 start hour	34398	0	38282	12	RW	Word		V1-F1H...24	h
V1	V1-F2n	Weekend/holiday defrost no. 2 start minutes	34399	0	38282	48	RW	Word		0...59	min
V1	V1-F2t	2nd weekend/holiday defrost duration	34400	0	38282	192	RW	Word		0...250	min
V1	V1-F2S	2nd weekend/holiday defrost end temperature	34401	0	38282	768	RW	Word	Y	-58.0...302.0	°C/°F
V1	V1-F3H	Weekend/holiday defrost no. 3 start hour	34402	0	38282	3072	RW	Word		V1-F2H...24	h
V1	V1-F3n	Weekend/holiday defrost no. 3 start minutes	34403	0	38282	12288	RW	Word		0...59	min
V1	V1-F3t	3rd weekend/holiday defrost duration	34404	0	38282	49152	RW	Word		0...250	min
V1	V1-F3S	3rd weekend/holiday defrost end temperature	34405	0	38283	3	RW	Word	Y	-58.0...302.0	°C/°F
V1	V1-F4H	Weekend/holiday defrost no. 4 start hour	34406	0	38283	12	RW	Word		V1-F3H...24	h
V1	V1-F4n	Weekend/holiday defrost no. 4 start minutes	34407	0	38283	48	RW	Word		0...59	min
V1	V1-F4t	4th weekend/holiday defrost duration	34408	0	38283	192	RW	Word		0...250	min
V1	V1-F4S	4th weekend/holiday defrost end temperature	34409	0	38283	768	RW	Word	Y	-58.0...302.0	°C/°F

V1	V1-F5H	Weekend/holiday defrost no. 5 start hour	34410	0	38283	3072	RW	Word		V1-F4H...24	h
V1	V1-F5n	Weekend/holiday defrost no. 5 start minutes	34411	0	38283	12288	RW	Word		0...59	min
V1	V1-F5t	5th weekend/holiday defrost duration	34412	0	38283	49152	RW	Word		0...250	min
V1	V1-F5S	5th weekend/holiday defrost end temperature	34413	0	38284	3	RW	Word	Y	-58.0...302.0	°C/°F
V1	V1-F6H	Weekend/holiday defrost no. 6 start hour	34414	0	38284	12	RW	Word		V1-F5H...24	h
V1	V1-F6n	Weekend/holiday defrost no. 6 start minutes	34415	0	38284	48	RW	Word		0...59	min
V1	V1-F6t	6th weekend/holiday defrost duration	34416	0	38284	192	RW	Word		0...250	min
V1	V1-F6S	6th weekend/holiday defrost end temperature	34417	0	38284	768	RW	Word	Y	-58.0...302.0	°C/°F
V1	V1-FP1	Selection of evaporator fan probe in normal mode	34480	0	38284	3072	RW	Word		0...7	num
V1	V1-FP2	Selection of evaporator fan probe in defrost	34481	0	38284	12288	RW	Word		0...7	num
V1	V1-FPt	FSt parameter mode (absolute or relative)	34482	0	38284	49152	RW	Word		0...1	num
V1	V1-FSt	Evaporator fan disabling temperature	34483	0	38285	3	RW	Word	Y	-58.0...302.0	°C/°F
V1	V1-FAd	Evaporator fan trigger differential	34484	0	38285	12	RW	Word		.1...25.0	°C/°F
V1	V1-Fdt	Evaporator fan activation delay time after a defrost cycle	34485	0	38285	48	RW	Word		0...250	min
V1	V1-dt	Dripping time	34490	0	38285	192	RW	Word		0...250	min
V1	V1-dFd	Evaporator fan cut-out during defrost	34488	0	38285	768	RW	Word		0...1	num
V1	V1-FCO	Evaporator fan status with compressor output Off	34487	0	38285	3072	RW	Word		0...4	num
V1	V1-Fod	Evaporator fan status with door open	34489	0	38285	12288	RW	Word		0...1	num
V1	V1-FdC	Evaporator fan shutoff delay after compressor deactivation	34486	0	38285	49152	RW	Word		0...250	min
V1	V1-FOn	Evaporator fan On time in cyclical regulator mode	34491	0	38286	3	RW	Word		0...250	min
V1	V1-FOF	Evaporator fan Off time in cyclical regulator mode	34492	0	38286	12	RW	Word		0...250	min
V1	V1-Fnn	Evaporator fan ON time in night mode (duty cycle)	34493	0	38286	48	RW	Word		0...250	min
V1	V1-FnF	Evaporator fan OFF time in night mode (duty cycle)	34494	0	38286	192	RW	Word		0...250	min
V1	V1-FE1	Variable speed fan probe selection	34593	0	38310	48	RW	Word		0...12	num
V1	V1-FEt	Setpoint mode	34594	0	38310	192	RW	Word		0...1	num

V1	V1-FES	Setpoint	34595	0	38310	768	RW	Word	Y	-58...302	num
V1	V1-FEd	Band	34596	0	38310	3072	RW	Word		0.1...50	num
V1	V1-FEu	Cut-off band	34597	0	38310	12288	RW	Word		0...25	num
V1	V1-FEC	Cut-off differential	34598	0	38310	49152	RW	Word		0.1...25	num
V1	V1-FEr	Fan shutoff delay after compressor deactivation	34599	0	38311	3	RW	Word		0...250	min
V1	V1-FE2	Minimum day percentage	34600	0	38311	12	RW	Word		0...100	%
V1	V1-FE3	Maximum day percentage with compressor on	34601	0	38311	48	RW	Word		0...100	%
V1	V1-FE4	Maximum day percentage with compressor off	34602	0	38311	192	RW	Word		0...100	%
V1	V1-FE5	Minimum night percentage	34603	0	38311	768	RW	Word		0...100	%
V1	V1-FE6	Maximum night percentage with compressor on	34604	0	38311	3072	RW	Word		0...100	%
V1	V1-FE7	Maximum night percentage with compressor off	34605	0	38311	12288	RW	Word		0...100	%
V1	V1-FE8	Percentage during defrost	34606	0	38311	49152	RW	Word		0...100	%
V1	V1-FE9	Percentage in the event of probe error	34607	0	38323	12	RW	Word		0...100	%
V1	V1-FEA	Maximum pick-up speed	34608	0	38323	48	RW	Word		0...100	%
V1	V1-FEb	Fan pick-up time	34609	0	38323	192	RW	Word		0...250	s
V1	V1-FEP	Fan forcing period at pick-up speed	34610	0	38323	768	RW	Word		0...250	min
V1	V1-rA1	Temperature alarm probe 1 selection	34508	0	38286	768	RW	Word		0...7	num
V1	V1-rA2	Temperature alarm probe 2 selection	34509	0	38286	3072	RW	Word		0...7	num
V1	V1-Att	Alarm mode (absolute or relative)	34510	0	38286	12288	RW	Word		0...1	num
V1	V1-AFd	Alarm activation differential	34511	0	38286	49152	RW	Word		.1...25.0	°C/°F
V1	V1-HA1	Maximum alarm 1 threshold	34512	0	38287	3	RW	Word	Y	V1-LA1...302.0	°C/°F
V1	V1-LA1	Minimum alarm 1 threshold	34513	0	38287	12	RW	Word	Y	-58.0...V1-HA1	°C/°F
V1	V1-HA2	Maximum alarm 2 threshold	34514	0	38287	48	RW	Word	Y	V1-LA2...302.0	°C/°F
V1	V1-LA2	Minimum alarm 2 threshold	34515	0	38287	192	RW	Word	Y	-58.0...V1-HA2	°C/°F
V1	V1-PAO	Temperature alarm exclusion time from power-on	34516	0	38287	768	RW	Word		0...10	h
V1	V1-dAO	Exclusion time for temperature alarms after a defrost cycle	34518	0	38287	3072	RW	Word		0...250	min
V1	V1-OAO	High and low temperature alarms exclusion time after closing the door	34517	0	38287	12288	RW	Word		0...10	h
V1	V1-tdO	Door open alarm exclusion time	34562	0	38287	49152	RW	Word		0...250	num
V1	V1-tA1	Probe 1 High/Minimum Alarm Delay	34519	0	38288	3	RW	Word		0...250	min

V1	V1-tA2	Probe 2 High/Minimum Alarm Delay	34520	0	38288	12	RW	Word		0...250	min
V1	V1-dAt	Defrost ended due to timeout alarm signaling	34478	0	38288	48	RW	Word		0...1	num
V1	V1-EAL	Regulators inhibited by external alarm	34522	0	38288	192	RW	Word		0...2	num
V1	V1-rA3	Leak detection probe selection	34581	0	38308	12288	RW	Word		0...8	num
V1	V1-ALL	Low threshold leak alarm	34582	0	38308	49152	RW	Word		0...V1-ALH	num
V1	V1-ALH	High threshold leak alarm	34583	0	38309	3	RW	Word		V1-ALL...100	num
V1	V1-dAL	Alarm leak differential	34584	0	38309	12	RW	Word		0.1...100	num
V1	V1-AL1	Time probe remains above the low threshold due to leak alarm activation	34585	0	38309	48	RW	Word		0...250	min
V1	V1-AL2	Time probe remains above the high threshold due to leak alarm activation	34592	0	38310	12	RW	Word		0...250	min
V1	V1-tP	Enables alarm acknowledgment with any key	34563	0	38288	768	RW	Word		0...1	num
V1	V1-Art	Regular watchdog alarm activation period	34507	0	38288	3072	RW	Word		0...250	min*10
V1	V1-dSd	Enable light relay from door switch	34504	0	38288	12288	RW	Word		0...1	num
V1	V1-dLt	Light relay off delay from door closure	34505	0	38288	49152	RW	Word		0...250	min
V1	V1-OFL	Enable cold room lights off via key during the delay set in parameter dLt	34506	0	38289	3	RW	Word		0...1	num
V1	V1-dOd	Enable utility shutoff upon door switch activation	34521	0	38289	12	RW	Word		0...3	num
V1	V1-dOA	Behavior forced by digital input	34523	0	38289	48	RW	Word		0...5	num
V1	V1-PEA	Enable forced behavior from door switch and/or external alarm.	34524	0	38289	192	RW	Word		0...3	num
V1	V1-dCO	Compressor activation delay from acknowledgment	34525	0	38289	768	RW	Word		0...250	min
V1	V1-dFO	Fan enabling delay from acknowledgment	34526	0	38289	3072	RW	Word		0...250	min
V1	V1-ASb	Instrument off active light/auxiliary digital input or key	34552	0	38289	12288	RW	Word		0...1	num
V1	V1-L00	Shared probe	34304	0	38289	49152	RW	Word		0...7	num
V1	V1-L01	Distributed viewing (refers to slave)	34305	0	38290	3	RW	Word		0...2	num
V1	V1-L02	Setpoint synchronization	34306	0	38290	12	RW	Word		0...1	num
V1	V1-L03	Defrost synchronization	34307	0	38290	48	RW	Word		0...2	num
V1	V1-L04	Inhibit resources at the end of defrost	34308	0	38290	192	RW	Word		0...1	num

V1	V1-L05	Stand-by synchronization	34309	0	38290	768	RW	Word		0...1	num
V1	V1-L06	Lights synchronization	34310	0	38290	3072	RW	Word		0...1	num
V1	V1-L07	Reduced set synchronization	34311	0	38290	12288	RW	Word		0...1	num
V1	V1-L08	AUX synchronization	34312	0	38290	49152	RW	Word		0...1	num
V1	V1-L09	Shared saturation probe	34313	0	38291	3	RW	Word		0...1	num
V1	V1-L10	Resource unlocking timeout during synchronized defrosts	34564	0	38291	12	RW	Word		0...250	min
V1	V1-L11	Number of devices connected in Link2	34314	0	38308	48	RW	Word		0...8	num
V1	V1-L12	Alarm relay sharing in Link2	34315	0	38308	192	RW	Word		0...2	num
V1	V1-L13	Link2 serial frame configuration	34575	0	38307	12288	RW	Word		0...1	num
V1	V1-L14	Force cool mode	34591	0	38310	3	RW	Word		0...1	num
V1	V1-dcS	Deep cooling setpoint	34498	0	38291	768	RW	Word	Y	-58.0...302.0	°C/°F
V1	V1-tdc	Deep cooling duration	34499	0	38291	3072	RW	Word		0...250	min
V1	V1-dcc	Defrost delay after deep cooling	34500	0	38291	12288	RW	Word		0...250	min
V1	V1-ESt	Type of action for the Energy Saving function	34427	0	38291	49152	RW	Word		0...8	num
V1	V1-ESF	Night mode activation (Energy Saving)	34495	0	38292	3	RW	Word		0...1	num
V1	V1-Cdt	Door closing time	34496	0	38292	12	RW	Word		0...255	min*10
V1	V1-ESo	Low consumption mode disabling timeout (door switch)	34497	0	38292	48	RW	Word		0...10	num
V1	V1-OS1	Offset on setpoint 1	34444	0	38292	192	RW	Word	Y	-50.0...50.0	°C/°F
V1	V1-OS2	Offset on setpoint 2	34445	0	38292	768	RW	Word	Y	-50.0...50.0	°C/°F
V1	V1-Od1	Refrigerated cabinets energy saving offset 1	34446	0	38292	3072	RW	Word	Y	-50.0...50.0	°C/°F
V1	V1-Od2	Refrigerated cabinets energy saving offset 2	34447	0	38292	12288	RW	Word	Y	-50.0...50.0	°C/°F
V1	V1-dn1	Differential during energy saving mode 1	34435	0	38292	49152	RW	Word	Y	-58.0...302.0	°C/°F
V1	V1-dn2	Differential during energy saving mode 2	34436	0	38293	3	RW	Word	Y	-58.0...302.0	°C/°F
V1	V1-EdH	Weekday energy saving start hour	34421	0	38293	12	RW	Word		0...24	h
V1	V1-Edn	Weekday energy saving start minutes	34422	0	38293	48	RW	Word		0...59	min
V1	V1-Edd	Weekday energy saving duration	34423	0	38293	192	RW	Word		1...72	h
V1	V1-EFH	Weekend/holiday energy saving start hour	34424	0	38293	768	RW	Word		0...24	h
V1	V1-EFn	Weekend/holiday energy saving start minutes	34425	0	38293	3072	RW	Word		0...59	min
V1	V1-EFd	Weekend/holiday energy saving duration	34426	0	38293	12288	RW	Word		1...72	h
V1	V1-FH	Frame heater probe selection	34527	0	38293	49152	RW	Word		0...9	num
V1	V1-FHt	Frame heater period	34529	0	38294	3	RW	Word		1...2500	s
V1	V1-FH0	Frame heater set	34530	0	38294	12	RW	Word	Y	-58.0...302.0	°C/°F
V1	V1-FH1	Frame heater offset	34531	0	38294	48	RW	Word		0...25.0	°C/°F

V1	V1-FH2	Frame heater band	34532	0	38294	192	RW	Word	Y	-58.0...302.0	°C/°F
V1	V1-FH3	Frame heater minimum percentage/duty-cycle	34533	0	38294	768	RW	Word		0...100	%
V1	V1-FH4	Frame heater maximum percentage/day duty-cycle	34534	0	38294	3072	RW	Word		0...100	%
V1	V1-FH5	Frame heater maximum percentage/night duty-cycle	34535	0	38294	12288	RW	Word		0...100	%
V1	V1-FH6	Frame heater percentage/duty-cycle in defrost	34536	0	38294	49152	RW	Word		0...100	%
V1	V1-LOC	Disable terminal	34539	0	38295	3	RW	Word		0...1	num
V1	V1-PS1	Password 1 value	34540	0	38295	12	RW	Word		0...250	num
V1	V1-PS2	Password 2 value	34541	0	38295	48	RW	Word		0...250	num
V1	V1-ndt	Display with decimal point	34542	0	38295	192	RW	Word		0...1	num
V1	V1-CA1	Analog input 1 calibration	34348	0	38295	768	RW	Word	Y	-30.0...30.0	°C/°F
V1	V1-CA2	Analog input 2 calibration	34349	0	38295	3072	RW	Word	Y	-30.0...30.0	°C/°F
V1	V1-CA3	Analog input 3 calibration	34350	0	38295	12288	RW	Word	Y	-30.0...30.0	°C/°F
V1	V1-CA4	Analog input 4 calibration	34351	0	38295	49152	RW	Word	Y	-30.0...30.0	°C/°F
V1	V1-CA5	Analog input 5 calibration	34352	0	38296	3	RW	Word	Y	-30.0...30.0	°C/°F
V1	V1-CA6	Analog input 6 calibration	34353	0	38296	12	RW	Word	Y	-30...30	bar/psi
V1	V1-CA7	Analog input 7 calibration	34354	0	38296	48	RW	Word	Y	-30...30	bar/psi
V1	V1-LdL	Minimum display value	34543	0	38296	192	RW	Word	Y	-58.0...V1-HdL	°C/°F
V1	V1-HdL	Maximum display value	34544	0	38296	768	RW	Word	Y	V1-LdL...302.0	°C/°F
V1	V1-ddL	Display lock mode during a defrost	34545	0	38296	3072	RW	Word		0...2	num
V1	V1-Ldd	Display lock timeout from end of defrost	34546	0	38296	12288	RW	Word		0...250	min
V1	V1-dro	Select °C / °F	34547	0	38296	49152	RW	Word		0...1	num
V1	V1-SbP	Pressure unit of measure	34548	0	38297	3	RW	Word		0...1	num
V1	V1-ddd	Select main display value	34549	0	38297	12	RW	Word		0...8	num
V1	V1-ddE	Resource displayed on ECHO	34550	0	38297	48	RW	Word		0...9	num
V1	V1-rPH	Receiver maximum valve opening %	34501	0	38297	192	RW	Word		0...5	num
V1	V1-H00	Select analog input type NTC/PTC	34316	0	38297	768	RW	Word		0...2	num
V1	V1-H02	Function activation time from terminal	34551	0	38297	3072	RW	Word		0...250	s
V1	V1-H08	Stand-by operating mode	34553	0	38297	12288	RW	Word		0...2	num
V1	V1-H11	Digital input 1 configurability and polarity	34319	0	38297	49152	RW	Word	Y	-18...18	num

V1	V1-H12	Digital input 2 configurability and polarity	34320	0	38298	3	RW	Word	Y	-18...18	num
V1	V1-H13	Digital input 3 configurability and polarity	34321	0	38298	12	RW	Word	Y	-18...18	num
V1	V1-H14	Digital input 4 configurability and polarity	34322	0	38298	48	RW	Word	Y	-18...18	num
V1	V1-H15	Digital input 5 configurability and polarity	34323	0	38298	192	RW	Word	Y	-18...18	num
V1	V1-H16	Digital input 6 configurability and polarity	34324	0	38298	768	RW	Word	Y	-18...18	num
V1	V1-H17	Digital input 7 configurability and polarity	34325	0	38298	3072	RW	Word	Y	-18...18	num
V1	V1-H18	Digital input 8 configurability and polarity	34326	0	38298	12288	RW	Word	Y	-18...18	num
V1	V1-i01	Digital input 9 configurability and polarity	34586	0	38309	192	RW	Word	Y	-18...18	num
V1	V1-i02	Digital input 10 configurability and polarity	34587	0	38309	768	RW	Word	Y	-18...18	num
V1	V1-dti	Digital inputs 1 and 2 delay unit of measure	34335	0	38298	49152	RW	Word		0...1	num
V1	V1-d11	D.I. 1 activation indication delay time	34327	0	38299	3	RW	Word		0...255	min/s
V1	V1-d12	D.I. 2 activation indication delay time	34328	0	38299	12	RW	Word		0...255	min/s
V1	V1-d13	D.I. 3 activation indication delay time	34329	0	38299	48	RW	Word		0...255	min
V1	V1-d14	D.I. 4 activation indication delay time	34330	0	38299	192	RW	Word		0...255	min
V1	V1-d15	D.I. 5 activation indication delay time	34331	0	38299	768	RW	Word		0...255	min
V1	V1-d16	D.I. 6 activation indication delay time	34332	0	38299	3072	RW	Word		0...255	min
V1	V1-d17	D.I. 7 activation indication delay time	34333	0	38299	12288	RW	Word		0...255	min
V1	V1-d18	D.I. 8 activation indication delay time	34334	0	38299	49152	RW	Word		0...255	min
V1	V1-01i	D.I. 9 activation indication delay time	34588	0	38309	3072	RW	Word		0...255	min/s
V1	V1-02i	D.I. 10 activation indication delay time	34589	0	38309	12288	RW	Word		0...255	min
V1	V1-H21	Configurability of digital output 1	34356	0	38300	3	RW	Word		0...19	num
V1	V1-H22	Configurability of digital output 2	34357	0	38300	12	RW	Word		0...19	num
V1	V1-H23	Configurability of digital output 3	34358	0	38300	48	RW	Word		0...19	num
V1	V1-H24	Configurability of digital output 4	34359	0	38300	192	RW	Word		0...19	num
V1	V1-H25	Configurability of digital output 5	34360	0	38300	768	RW	Word		0...19	num
V1	V1-H27	Configurability of digital output 7	34362	0	38300	12288	RW	Word		0...19	num
V1	V1-H29	Enable buzzer	34363	0	38300	49152	RW	Word		0...1	num

V1	V1-d01	Configurability of digital output 8	34579	0	38308	768	RW	Word		0...19	num
V1	V1-d02	Configurability of digital output 9	34580	0	38308	3072	RW	Word		0...19	num
V1	V1-H31	Configurability of the UP key	34554	0	38301	3	RW	Word		0...9	num
V1	V1-H32	Configurability of the DOWN key	34555	0	38301	12	RW	Word		0...9	num
V1	V1-H33	Configurability of the ESC key	34556	0	38301	48	RW	Word		0...9	num
V1	V1-H34	Configurability of the Free 1 key	34557	0	38301	192	RW	Word		0...9	num
V1	V1-H35	Configurability of the Free 2 key	34558	0	38301	768	RW	Word		0...9	num
V1	V1-H36	Configurability of the Free 3 key	34559	0	38301	3072	RW	Word		0...9	num
V1	V1-H37	Configurability of the Free 4 key	34560	0	38301	12288	RW	Word		0...9	num
V1	V1-H41	Analog input 1 calibration	34336	0	38301	49152	RW	Word		0...2	num
V1	V1-H42	Analog input 2 calibration	34337	0	38302	3	RW	Word		0...2	num
V1	V1-H43	Analog input 3 calibration	34338	0	38302	12	RW	Word		0...2	num
V1	V1-H44	Analog input 4 calibration	34339	0	38302	48	RW	Word		0...2	num
V1	V1-H45	Analog input 5 calibration	34340	0	38302	192	RW	Word		0...2	num
V1	V1-H46	Analog input 6 calibration	34341	0	38302	768	RW	Word		0...2	num
V1	V1-H47	Analog input 7 calibration	34342	0	38302	3072	RW	Word		0...2	num
V1	V1-H48	Analog input 8 calibration	34590	0	38309	49152	RW	Word		0...2	num
V1	V1-H50	Configurability of analog output 1	34364	0	38302	12288	RW	Word		0...1	num
V1	V1-H51	Function associated with analog output	34365	0	38302	49152	RW	Word		0...3	num
V1	V1-H68	RTC present	34366	0	38303	3	RW	Word		0...1	num
V1	V1-H70	Selection of 1st sensor for virtual probe	34344	0	38303	12	RW	Word		0...5	num
V1	V1-H71	Selection of 2nd sensor for virtual probe	34345	0	38303	48	RW	Word		0...5	num
V1	V1-H72	Day virtual probe calculation %	34346	0	38303	192	RW	Word		0...100	%
V1	V1-H73	Night virtual probe calculation %	34347	0	38303	768	RW	Word		0...100	%
V1	V1-H74	Selection of 1st sensor for filtered virtual probe	34576	0	38307	49152	RW	Word		0...6	num
V1	V1-H75	Percentage in thousandths of the incoming signal for filtered virtual probe	34577	0	38308	3	RW	Word		1...1000	num
V1	V1-H76	Filtered virtual probe offset	34578	0	38308	12	RW	Word	Y	-999.9...999.9	num
V1	V1-EtY	Selection of electronic expansion valve driver	34561	0	38303	3072	RW	Word		0...2	num
V1	V1-OHP	Selection of oil temperature probe	34568	0	38306	12288	RW	Word		0...8	num

V1	V1-OSP	Oil heater setpoint	34569	0	38306	49152	RW	Word	Y	V1-OLS...V1-OHS	°C/°F
V1	V1-OHd	Oil heater differential	34570	0	38307	3	RW	Word		.1...25.0	°C/°F
V1	V1-OHS	Maximum oil heater setpoint value that can be set	34572	0	38307	48	RW	Word	Y	V1-OLS...302.0	°C/°F
V1	V1-OLS	Minimum oil heater setpoint value that can be set	34573	0	38307	192	RW	Word	Y	-58.0...V1-OHS	°C/°F
V1	UL	Visibility of parameter transfer function (Device -> UNICARD/MFK)	-	-	38306	3	RW	Word		0...3	num
V1	dL	Visibility of parameter transfer function (UNICARD/MFK -> Device)	-	-	38306	12	RW	Word		0...3	num
V1	Fr	Visibility of UNICARD/MFK formatting function	-	-	38306	48	RW	Word		0...3	num

Application 2 parameters											
V2	V2-rE	Regulation type	34812	0	38368	3	RW	Word		0...6	num
V2	V2-rP1	Thermostat regulation probe 1	34813	0	38368	12	RW	Word		0...8	num
V2	V2-rP2	Thermostat regulation probe 2	34814	0	38368	48	RW	Word		0...9	num
V2	V2-SP1	Regulation setpoint 1	34815	0	38368	192	RW	Word	Y	V2-LS1...V2-HS1	°C/°F
V2	V2-dF1	Setpoint differential 1	34816	0	38368	768	RW	Word	Y	-58.0...302.0	°C/°F
V2	V2-SP2	Regulation setpoint 2	34817	0	38368	3072	RW	Word	Y	V2-LS2...V2-HS2	°C/°F
V2	V2-dF2	Setpoint differential 2	34818	0	38368	12288	RW	Word	Y	-58.0...302.0	°C/°F
V2	V2-Stt	Differential management mode	34821	0	38368	49152	RW	Word		0...1	num
V2	V2-HS1	Maximum value that can be set for Setpoint 1	34824	0	38369	3	RW	Word	Y	V2-LS1...V2-HdL	°C/°F
V2	V2-LS1	Minimum value that can be set for Setpoint 1	34825	0	38369	12	RW	Word	Y	V2-LdL...V2-HS1	°C/°F
V2	V2-HS2	Maximum value that can be set for Setpoint 2	34826	0	38369	48	RW	Word	Y	V2-LS2...V2-HdL	°C/°F
V2	V2-LS2	Minimum value that can be set for Setpoint 2	34827	0	38369	192	RW	Word	Y	V2-LdL...V2-HS2	°C/°F
V2	V2-HC1	Setpoint 1 operating mode (Heating/Cooling)	34822	0	38369	768	RW	Word		0...1	num
V2	V2-HC2	Setpoint 2 operating mode (Heating/Cooling)	34823	0	38369	3072	RW	Word		0...1	num
V2	V2-Cit	Minimum compressor output activation time	34832	0	38369	49152	RW	Word		0...250	min
V2	V2-CAt	Maximum compressor output activation time	34833	0	38370	3	RW	Word		0...250	min
V2	V2-Ont	Compressor output ON time if regulation probe is faulty	34838	0	38370	12	RW	Word		0...250	min
V2	V2-OFt	Compressor output OFF time if regulation probe is faulty	34839	0	38370	48	RW	Word		0...250	min
V2	V2-dOn	Compressor output activation delay from call	34834	0	38370	192	RW	Word		0...250	s

V2	V2-dOF	Compressor output activation delay from switch-off	34835	0	38370	768	RW	Word		0...250	min
V2	V2-dbi	Delay between two consecutive compressor output power-ons	34836	0	38370	3072	RW	Word		0...250	min
V2	V2-OfO	Output activation delay at startup	34837	0	38370	12288	RW	Word		0...250	min
V2	V2-CFP	Condenser pre-ventilation time in Heat/Cool	34921	0	38371	12	RW	Word		0...255	s
V2	V2-CFd	Condenser fan cut-out during defrosting.	34922	0	38371	48	RW	Word		0...1	num
V2	V2-OF1	Remote offset	34843	0	38371	192	RW	Word	Y	-50.0...50.0	°C/°F
V2	V2-Pot	Pump down time	34949	0	38402	192	RW	Word		0...250	s
V2	V2-SS1	Compressor softstart: advance hotgas valve opening	34950	0	38402	768	RW	Word		0...250	s
V2	V2-SS2	Compressor softstart: delay hotgas valve closing	34951	0	38402	3072	RW	Word		0...250	s
V2	V2-dP1	Select defrost probe 1	34844	0	38371	768	RW	Word		0...8	num
V2	V2-dP2	Defrost probe 2 selection	34845	0	38371	3072	RW	Word		0...8	num
V2	V2-dtY	Type of defrost	34848	0	38371	12288	RW	Word		0...4	num
V2	V2-dFt	Dual evaporator defrost activation mode	34846	0	38371	49152	RW	Word		0...2	num
V2	V2-dit	Interval between defrosts	34849	0	38372	3	RW	Word		0...250	h/min/s
V2	V2-dt1	Unit of measure for defrost intervals	34852	0	38372	12	RW	Word		0...2	num
V2	V2-dt2	Unit of measure for defrost duration	34853	0	38372	48	RW	Word		0...2	num
V2	V2-dCt	Defrost interval count mode	34847	0	38372	192	RW	Word		0...5	num
V2	V2-dOH	Defrost cycle activation delay from the call	34854	0	38372	768	RW	Word		0...250	min
V2	V2-dE1	Evaporator 1 defrost maximum duration	34850	0	38372	3072	RW	Word		1...250	h/min/s
V2	V2-dE2	Evaporator 2 defrost maximum duration	34851	0	38372	12288	RW	Word		1...250	h/min/s
V2	V2-dS1	Evaporator 1 defrost end temperature	34856	0	38372	49152	RW	Word	Y	-58.0...302.0	°C/°F
V2	V2-dS2	Evaporator 2 defrost end temperature	34857	0	38373	3	RW	Word	Y	-58.0...302.0	°C/°F
V2	V2-dSS	Temperature threshold for starting defrost	34855	0	38373	12	RW	Word	Y	-58.0...302.0	°C/°F
V2	V2-dPO	Defrost activation request at power-on	34858	0	38373	48	RW	Word		0...1	num
V2	V2-tcd	Compressor output activation/deactivation time before a defrost	34859	0	38373	192	RW	Word	Y	-60...60	min
V2	V2-ndE	minimum defrost duration time	34860	0	38373	768	RW	Word		0...250	h/min/s
V2	V2-PdC	Hot gas extraction time at the end of the defrost	34861	0	38373	3072	RW	Word		0...250	min
V2	V2-tPd	Pump down time before defrost start	34863	0	38373	12288	RW	Word		0...255	min

V2	V2-dPH	Regular defrost start hour	34802	0	38373	49152	RW	Word		0...24	h
V2	V2-dPn	Regular defrost start minutes	34803	0	38374	3	RW	Word		0...59	min
V2	V2-dPd	Regular defrost interval duration	34804	0	38374	12	RW	Word		1...7	day
V2	V2-Fd1	1st weekend/holiday day	34751	0	38374	48	RW	Word		0...7	num
V2	V2-Fd2	2nd weekend/holiday day	34752	0	38374	192	RW	Word		0...7	num
V2	V2-Edt	Timeout and defrost end temperature specific to each event	34753	0	38374	768	RW	Word		0...1	num
V2	V2-PrH	Basin heater pre-activation time	34958	0	38403	3072	RW	Word		0...255	min
V2	V2-Fdn	Weekday defrost number	34701	0	38408	3	RW	Word		0...250	num
V2	V2-FFn	Weekend/holiday defrost number	34702	0	38408	12	RW	Word		0...250	num
V2	V2-d1H	Weekday defrost no. 1 start hour	34754	0	38374	3072	RW	Word		0...24	h
V2	V2-d1n	Weekday defrost no. 1 start minute	34755	0	38374	12288	RW	Word		0...59	min
V2	V2-d1t	1st weekday defrost duration	34756	0	38374	49152	RW	Word		0...250	min
V2	V2-d1S	1st weekday defrost end temperature	34757	0	38375	3	RW	Word	Y	-58.0...302.0	°C/°F
V2	V2-d2H	Weekday defrost no. 2 start hour	34758	0	38375	12	RW	Word		V2-d1H...24	h
V2	V2-d2n	Weekday defrost no. 2 start minutes	34759	0	38375	48	RW	Word		0...59	min
V2	V2-d2t	2nd weekday defrost duration	34760	0	38375	192	RW	Word		0...250	min
V2	V2-d2S	2nd weekday defrost end temperature	34761	0	38375	768	RW	Word	Y	-58.0...302.0	°C/°F
V2	V2-d3H	Weekday defrost no. 3 start hour	34762	0	38375	3072	RW	Word		V2-d2H...24	h
V2	V2-d3n	Weekday defrost no. 3 start minutes	34763	0	38375	12288	RW	Word		0...59	min
V2	V2-d3t	3rd weekday defrost duration	34764	0	38375	49152	RW	Word		0...250	min
V2	V2-d3S	3rd weekday defrost end temperature	34765	0	38376	3	RW	Word	Y	-58.0...302.0	°C/°F
V2	V2-d4H	Weekday defrost no. 4 start hour	34766	0	38376	12	RW	Word		V2-d3H...24	h
V2	V2-d4n	Weekday defrost no. 4 start minutes	34767	0	38376	48	RW	Word		0...59	min
V2	V2-d4t	4th weekday defrost duration	34768	0	38376	192	RW	Word		0...250	min
V2	V2-d4S	4th weekday defrost end temperature	34769	0	38376	768	RW	Word	Y	-58.0...302.0	°C/°F
V2	V2-d5H	Weekday defrost no. 5 start hour	34770	0	38376	3072	RW	Word		V2-d4H...24	h
V2	V2-d5n	Weekday defrost no. 5 start minutes	34771	0	38376	12288	RW	Word		0...59	min
V2	V2-d5t	5th weekday defrost duration	34772	0	38376	49152	RW	Word		0...250	min
V2	V2-d5S	5th weekday defrost end temperature	34773	0	38377	3	RW	Word	Y	-58.0...302.0	°C/°F
V2	V2-d6H	Weekday defrost no. 6 start hour	34774	0	38377	12	RW	Word		V2-d5H...24	h

V2	V2-d6n	Weekday defrost no. 6 start minutes	34775	0	38377	48	RW	Word		0...59	min
V2	V2-d6t	6th weekday defrost duration	34776	0	38377	192	RW	Word		0...250	min
V2	V2-d6S	6th weekday defrost end temperature	34777	0	38377	768	RW	Word	Y	-58.0...302.0	°C/°F
V2	V2-F1H	Weekend/holiday defrost no. 1 start hour	34778	0	38377	3072	RW	Word		0...24	h
V2	V2-F1n	Weekend/holiday defrost no. 1 start minute	34779	0	38377	12288	RW	Word		0...59	min
V2	V2-F1t	1st weekend/holiday defrost duration	34780	0	38377	49152	RW	Word		0...250	min
V2	V2-F1S	1st weekend/holiday defrost end temperature	34781	0	38378	3	RW	Word	Y	-58.0...302.0	°C/°F
V2	V2-F2H	Weekend/holiday defrost no. 2 start hour	34782	0	38378	12	RW	Word		V2-F1H...24	h
V2	V2-F2n	Weekend/holiday defrost no. 2 start minutes	34783	0	38378	48	RW	Word		0...59	min
V2	V2-F2t	2nd weekend/holiday defrost duration	34784	0	38378	192	RW	Word		0...250	min
V2	V2-F2S	2nd weekend/holiday defrost end temperature	34785	0	38378	768	RW	Word	Y	-58.0...302.0	°C/°F
V2	V2-F3H	Weekend/holiday defrost no. 3 start hour	34786	0	38378	3072	RW	Word		V2-F2H...24	h
V2	V2-F3n	Weekend/holiday defrost no. 3 start minutes	34787	0	38378	12288	RW	Word		0...59	min
V2	V2-F3t	3rd weekend/holiday defrost duration	34788	0	38378	49152	RW	Word		0...250	min
V2	V2-F3S	3rd weekend/holiday defrost end temperature	34789	0	38379	3	RW	Word	Y	-58.0...302.0	°C/°F
V2	V2-F4H	Weekend/holiday defrost no. 4 start hour	34790	0	38379	12	RW	Word		V2-F3H...24	h
V2	V2-F4n	Weekend/holiday defrost no. 4 start minutes	34791	0	38379	48	RW	Word		0...59	min
V2	V2-F4t	4th weekend/holiday defrost duration	34792	0	38379	192	RW	Word		0...250	min
V2	V2-F4S	4th weekend/holiday defrost end temperature	34793	0	38379	768	RW	Word	Y	-58.0...302.0	°C/°F
V2	V2-F5H	Weekend/holiday defrost no. 5 start hour	34794	0	38379	3072	RW	Word		V2-F4H...24	h
V2	V2-F5n	Weekend/holiday defrost no. 5 start minutes	34795	0	38379	12288	RW	Word		0...59	min
V2	V2-F5t	5th weekend/holiday defrost duration	34796	0	38379	49152	RW	Word		0...250	min
V2	V2-F5S	5th weekend/holiday defrost end temperature	34797	0	38380	3	RW	Word	Y	-58.0...302.0	°C/°F
V2	V2-F6H	Weekend/holiday defrost no. 6 start hour	34798	0	38380	12	RW	Word		V2-F5H...24	h

V2	V2-F6n	Weekend/holiday defrost no. 6 start minutes	34799	0	38380	48	RW	Word		0...59	min
V2	V2-F6t	6th weekend/holiday defrost duration	34800	0	38380	192	RW	Word		0...250	min
V2	V2-F6S	6th weekend/holiday defrost end temperature	34801	0	38380	768	RW	Word	Y	-58.0...302.0	°C/°F
V2	V2-FP1	Selection of evaporator fan probe in normal mode	34864	0	38380	3072	RW	Word		0...7	num
V2	V2-FP2	Selection of evaporator fan probe in defrost	34865	0	38380	12288	RW	Word		0...7	num
V2	V2-FPt	FSt parameter mode (absolute or relative)	34866	0	38380	49152	RW	Word		0...1	num
V2	V2-FSt	Evaporator fan disabling temperature	34867	0	38381	3	RW	Word	Y	-58.0...302.0	°C/°F
V2	V2-FAd	Evaporator fan trigger differential	34868	0	38381	12	RW	Word		.1...25.0	°C/°F
V2	V2-Fdt	Evaporator fan activation delay time after a defrost cycle	34869	0	38381	48	RW	Word		0...250	min
V2	V2-dt	Dripping time	34874	0	38381	192	RW	Word		0...250	min
V2	V2-dFd	Evaporator fan cut-out during defrost	34872	0	38381	768	RW	Word		0...1	num
V2	V2-FCO	Evaporator fan status with compressor output Off	34871	0	38381	3072	RW	Word		0...4	num
V2	V2-Fod	Evaporator fan status with door open	34873	0	38381	12288	RW	Word		0...1	num
V2	V2-FdC	Evaporator fan shutoff delay after compressor deactivation	34870	0	38381	49152	RW	Word		0...250	min
V2	V2-FOn	Evaporator fan On time in cyclical regulator mode	34875	0	38382	3	RW	Word		0...250	min
V2	V2-FOF	Evaporator fan Off time in cyclical regulator mode	34876	0	38382	12	RW	Word		0...250	min
V2	V2-Fnn	Evaporator fan ON time in night mode (duty cycle)	34877	0	38382	48	RW	Word		0...250	min
V2	V2-FnF	Evaporator fan OFF time in night mode (duty cycle)	34878	0	38382	192	RW	Word		0...250	min
V2	V2-FE1	Variable speed fan probe selection	34977	0	38406	48	RW	Word		0...12	num
V2	V2-FEt	Setpoint mode	34978	0	38406	192	RW	Word		0...1	num
V2	V2-FES	Setpoint	34979	0	38406	768	RW	Word	Y	-58...302	num
V2	V2-FEd	Band	34980	0	38406	3072	RW	Word		0.1...50	num
V2	V2-FEu	Cut-off band	34981	0	38406	12288	RW	Word		0...25	num
V2	V2-FEC	Cut-off differential	34982	0	38406	49152	RW	Word		0.1...25	num
V2	V2-FEr	Fan shutoff delay after compressor deactivation	34983	0	38407	3	RW	Word		0...250	min
V2	V2-FE2	Minimum day percentage	34984	0	38407	12	RW	Word		0...100	%
V2	V2-FE3	Maximum day percentage with compressor on	34985	0	38407	48	RW	Word		0...100	%

V2	V2-FE4	Maximum day percentage with compressor off	34986	0	38407	192	RW	Word		0...100	%
V2	V2-FE5	Minimum night percentage	34987	0	38407	768	RW	Word		0...100	%
V2	V2-FE6	Maximum night percentage with compressor on	34988	0	38407	3072	RW	Word		0...100	%
V2	V2-FE7	Maximum night percentage with compressor off	34989	0	38407	12288	RW	Word		0...100	%
V2	V2-FE8	Percentage during defrost	34990	0	38407	49152	RW	Word		0...100	%
V2	V2-FE9	Percentage in the event of probe error	34991	0	38419	12	RW	Word		0...100	%
V2	V2-FEA	Maximum pick-up speed	34992	0	38419	48	RW	Word		0...100	%
V2	V2-FEb	Fan pick-up time	34993	0	38419	192	RW	Word		0...250	s
V2	V2-FEP	Fan forcing period at pick-up speed	34994	0	38419	768	RW	Word		0...250	min
V2	V2-rA1	Temperature alarm probe 1 selection	34892	0	38382	768	RW	Word		0...7	num
V2	V2-rA2	Temperature alarm probe 2 selection	34893	0	38382	3072	RW	Word		0...7	num
V2	V2-Att	Alarm mode (absolute or relative)	34894	0	38382	12288	RW	Word		0...1	num
V2	V2-AFd	Alarm activation differential	34895	0	38382	49152	RW	Word		.1...25.0	°C/°F
V2	V2-HA1	Maximum alarm 1 threshold	34896	0	38383	3	RW	Word	Y	V2-LA1...302.0	°C/°F
V2	V2-LA1	Minimum alarm 1 threshold	34897	0	38383	12	RW	Word	Y	-58.0...V2-HA1	°C/°F
V2	V2-HA2	Maximum alarm 2 threshold	34898	0	38383	48	RW	Word	Y	V2-LA2...302.0	°C/°F
V2	V2-LA2	Minimum alarm 2 threshold	34899	0	38383	192	RW	Word	Y	-58.0...V2-HA2	°C/°F
V2	V2-PAO	Temperature alarm exclusion time from power-on	34900	0	38383	768	RW	Word		0...10	h
V2	V2-dAO	Exclusion time for temperature alarms after a defrost cycle	34902	0	38383	3072	RW	Word		0...250	min
V2	V2-OAO	High and low temperature alarms exclusion time after closing the door	34901	0	38383	12288	RW	Word		0...10	h
V2	V2-tdO	Door open alarm exclusion time	34946	0	38383	49152	RW	Word		0...250	num
V2	V2-tA1	Probe 1 High/Minimum Alarm Delay	34903	0	38384	3	RW	Word		0...250	min
V2	V2-tA2	Probe 2 High/Minimum Alarm Delay	34904	0	38384	12	RW	Word		0...250	min
V2	V2-dAt	Defrost ended due to timeout alarm signaling	34862	0	38384	48	RW	Word		0...1	num
V2	V2-EAL	Regulators inhibited by external alarm	34906	0	38384	192	RW	Word		0...2	num
V2	V2-rA3	Leak detection probe selection	34965	0	38404	12288	RW	Word		0...8	num
V2	V2-ALL	Low threshold leak alarm	34966	0	38404	49152	RW	Word		0...V2-ALH	num

V2	V2-ALH	High threshold leak alarm	34967	0	38405	3	RW	Word		V2-ALL...100	num
V2	V2-dAL	Alarm leak differential	34968	0	38405	12	RW	Word		0.1...100	num
V2	V2-AL1	Time probe remains above the low threshold due to leak alarm activation	34969	0	38405	48	RW	Word		0...250	min
V2	V2-AL2	Time probe remains above the high threshold due to leak alarm activation	34976	0	38406	12	RW	Word		0...250	min
V2	V2-tP	Enables alarm acknowledgment with any key	34947	0	38384	768	RW	Word		0...1	num
V2	V2-Art	Regular watchdog alarm activation period	34891	0	38384	3072	RW	Word		0...250	min*10
V2	V2-dSd	Enable light relay from door switch	34888	0	38384	12288	RW	Word		0...1	num
V2	V2-dLt	Light relay off delay from door closure	34889	0	38384	49152	RW	Word		0...250	min
V2	V2-OFL	Enable cold room lights off via key during the delay set in parameter dLt	34890	0	38385	3	RW	Word		0...1	num
V2	V2-dOd	Enable utility shutoff upon door switch activation	34905	0	38385	12	RW	Word		0...3	num
V2	V2-dOA	Behavior forced by digital input	34907	0	38385	48	RW	Word		0...5	num
V2	V2-PEA	Enable forced behavior from door switch and/or external alarm.	34908	0	38385	192	RW	Word		0...3	num
V2	V2-dCO	Compressor activation delay from acknowledgment	34909	0	38385	768	RW	Word		0...250	min
V2	V2-dFO	Fan enabling delay from acknowledgment	34910	0	38385	3072	RW	Word		0...250	min
V2	V2-ASb	Instrument off active light/auxiliary digital input or key	34936	0	38385	12288	RW	Word		0...1	num
V2	V2-L00	Shared probe	34688	0	38385	49152	RW	Word		0...7	num
V2	V2-L01	Distributed viewing (refers to slave)	34689	0	38386	3	RW	Word		0...2	num
V2	V2-L02	Setpoint synchronization	34690	0	38386	12	RW	Word		0...1	num
V2	V2-L03	Defrost synchronization	34691	0	38386	48	RW	Word		0...2	num
V2	V2-L04	Inhibit resources at the end of defrost	34692	0	38386	192	RW	Word		0...1	num
V2	V2-L05	Stand-by synchronization	34693	0	38386	768	RW	Word		0...1	num
V2	V2-L06	Lights synchronization	34694	0	38386	3072	RW	Word		0...1	num
V2	V2-L07	Reduced set synchronization	34695	0	38386	12288	RW	Word		0...1	num
V2	V2-L08	AUX synchronization	34696	0	38386	49152	RW	Word		0...1	num
V2	V2-L09	Shared saturation probe	34697	0	38387	3	RW	Word		0...1	num
V2	V2-L10	Resource unlocking timeout during synchronized defrosts	34948	0	38387	12	RW	Word		0...250	min

V2	V2-L11	Number of devices connected in Link2	34698	0	38404	48	RW	Word		0...8	num
V2	V2-L12	Alarm relay sharing in Link2	34699	0	38404	192	RW	Word		0...2	num
V2	V2-L13	Link2 serial frame configuration	34959	0	38403	12288	RW	Word		0...1	num
V2	V2-L14	Force cool mode	34975	0	38406	3	RW	Word		0...1	num
V2	V2-dcS	Deep cooling setpoint	34882	0	38387	768	RW	Word	Y	-58.0...302.0	°C/°F
V2	V2-tdc	Deep cooling duration	34883	0	38387	3072	RW	Word		0...250	min
V2	V2-dcc	Defrost delay after deep cooling	34884	0	38387	12288	RW	Word		0...250	min
V2	V2-ESt	Type of action for the Energy Saving function	34811	0	38387	49152	RW	Word		0...8	num
V2	V2-ESF	Night mode activation (Energy Saving)	34879	0	38388	3	RW	Word		0...1	num
V2	V2-Cdt	Door closing time	34880	0	38388	12	RW	Word		0...255	min*10
V2	V2-ESo	Low consumption mode disabling timeout (door switch)	34881	0	38388	48	RW	Word		0...10	num
V2	V2-OS1	Offset on setpoint 1	34828	0	38388	192	RW	Word	Y	-50.0...50.0	°C/°F
V2	V2-OS2	Offset on setpoint 2	34829	0	38388	768	RW	Word	Y	-50.0...50.0	°C/°F
V2	V2-Od1	Refrigerated cabinets energy saving offset 1	34830	0	38388	3072	RW	Word	Y	-50.0...50.0	°C/°F
V2	V2-Od2	Refrigerated cabinets energy saving offset 2	34831	0	38388	12288	RW	Word	Y	-50.0...50.0	°C/°F
V2	V2-dn1	Differential during energy saving mode 1	34819	0	38388	49152	RW	Word	Y	-58.0...302.0	°C/°F
V2	V2-dn2	Differential during energy saving mode 2	34820	0	38389	3	RW	Word	Y	-58.0...302.0	°C/°F
V2	V2-EdH	Weekday energy saving start hour	34805	0	38389	12	RW	Word		0...24	h
V2	V2-Edn	Weekday energy saving start minutes	34806	0	38389	48	RW	Word		0...59	min
V2	V2-Edd	Weekday energy saving duration	34807	0	38389	192	RW	Word		1...72	h
V2	V2-EFH	Weekend/holiday energy saving start hour	34808	0	38389	768	RW	Word		0...24	h
V2	V2-EFn	Weekend/holiday energy saving start minutes	34809	0	38389	3072	RW	Word		0...59	min
V2	V2-EFd	Weekend/holiday energy saving duration	34810	0	38389	12288	RW	Word		1...72	h
V2	V2-FH	Frame heater probe selection	34911	0	38389	49152	RW	Word		0...9	num
V2	V2-FHt	Frame heater period	34913	0	38390	3	RW	Word		1...2500	s
V2	V2-FH0	Frame heater set	34914	0	38390	12	RW	Word	Y	-58.0...302.0	°C/°F
V2	V2-FH1	Frame heater offset	34915	0	38390	48	RW	Word		0...25.0	°C/°F
V2	V2-FH2	Frame heater band	34916	0	38390	192	RW	Word	Y	-58.0...302.0	°C/°F
V2	V2-FH3	Frame heater minimum percentage/duty-cycle	34917	0	38390	768	RW	Word		0...100	%
V2	V2-FH4	Frame heater maximum percentage/day duty-cycle	34918	0	38390	3072	RW	Word		0...100	%

V2	V2-FH5	Frame heater maximum percentage/night duty-cycle	34919	0	38390	12288	RW	Word		0...100	%
V2	V2-FH6	Frame heater percentage/duty-cycle in defrost	34920	0	38390	49152	RW	Word		0...100	%
V2	V2-LOC	Disable terminal	34923	0	38391	3	RW	Word		0...1	num
V2	V2-PS1	Password 1 value	34924	0	38391	12	RW	Word		0...250	num
V2	V2-PS2	Password 2 value	34925	0	38391	48	RW	Word		0...250	num
V2	V2-ndt	Display with decimal point	34926	0	38391	192	RW	Word		0...1	num
V2	V2-CA1	Analog input 1 calibration	34732	0	38391	768	RW	Word	Y	-30.0...30.0	°C/°F
V2	V2-CA2	Analog input 2 calibration	34733	0	38391	3072	RW	Word	Y	-30.0...30.0	°C/°F
V2	V2-CA3	Analog input 3 calibration	34734	0	38391	12288	RW	Word	Y	-30.0...30.0	°C/°F
V2	V2-CA4	Analog input 4 calibration	34735	0	38391	49152	RW	Word	Y	-30.0...30.0	°C/°F
V2	V2-CA5	Analog input 5 calibration	34736	0	38392	3	RW	Word	Y	-30.0...30.0	°C/°F
V2	V2-CA6	Analog input 6 calibration	34737	0	38392	12	RW	Word	Y	-30...30	bar/psi
V2	V2-CA7	Analog input 7 calibration	34738	0	38392	48	RW	Word	Y	-30...30	bar/psi
V2	V2-LdL	Minimum display value	34927	0	38392	192	RW	Word	Y	-58.0...V2-HdL	°C/°F
V2	V2-HdL	Maximum display value	34928	0	38392	768	RW	Word	Y	V2-LdL...302.0	°C/°F
V2	V2-ddL	Display lock mode during a defrost	34929	0	38392	3072	RW	Word		0...2	num
V2	V2-Ldd	Display lock timeout from end of defrost	34930	0	38392	12288	RW	Word		0...250	min
V2	V2-dro	Select °C / °F	34931	0	38392	49152	RW	Word		0...1	num
V2	V2-SbP	Pressure unit of measure	34932	0	38393	3	RW	Word		0...1	num
V2	V2-ddd	Select main display value	34933	0	38393	12	RW	Word		0...8	num
V2	V2-ddE	Resource displayed on ECHO	34934	0	38393	48	RW	Word		0...9	num
V2	V2-rPH	Receiver maximum valve opening %	34885	0	38393	192	RW	Word		0...5	num
V2	V2-H00	Select analog input type NTC/PTC	34700	0	38393	768	RW	Word		0...2	num
V2	V2-H02	Function activation time from terminal	34935	0	38393	3072	RW	Word		0...250	s
V2	V2-H08	Stand-by operating mode	34937	0	38393	12288	RW	Word		0...2	num
V2	V2-H11	Digital input 1 configurability and polarity	34703	0	38393	49152	RW	Word	Y	-18...18	num
V2	V2-H12	Digital input 2 configurability and polarity	34704	0	38394	3	RW	Word	Y	-18...18	num
V2	V2-H13	Digital input 3 configurability and polarity	34705	0	38394	12	RW	Word	Y	-18...18	num
V2	V2-H14	Digital input 4 configurability and polarity	34706	0	38394	48	RW	Word	Y	-18...18	num

V2	V2-H15	Digital input 5 configurability and polarity	34707	0	38394	192	RW	Word	Y	-18...18	num
V2	V2-H16	Digital input 6 configurability and polarity	34708	0	38394	768	RW	Word	Y	-18...18	num
V2	V2-H17	Digital input 7 configurability and polarity	34709	0	38394	3072	RW	Word	Y	-18...18	num
V2	V2-H18	Digital input 8 configurability and polarity	34710	0	38394	12288	RW	Word	Y	-18...18	num
V2	V2-i01	Digital input 9 configurability and polarity	34970	0	38405	192	RW	Word	Y	-18...18	num
V2	V2-i02	Digital input 10 configurability and polarity	34971	0	38405	768	RW	Word	Y	-18...18	num
V2	V2-dti	Digital inputs 1 and 2 delay unit of measure	34719	0	38394	49152	RW	Word		0...1	num
V2	V2-d11	D.I. 1 activation indication delay time	34711	0	38395	3	RW	Word		0...255	min/s
V2	V2-d12	D.I. 2 activation indication delay time	34712	0	38395	12	RW	Word		0...255	min/s
V2	V2-d13	D.I. 3 activation indication delay time	34713	0	38395	48	RW	Word		0...255	min
V2	V2-d14	D.I. 4 activation indication delay time	34714	0	38395	192	RW	Word		0...255	min
V2	V2-d15	D.I. 5 activation indication delay time	34715	0	38395	768	RW	Word		0...255	min
V2	V2-d16	D.I. 6 activation indication delay time	34716	0	38395	3072	RW	Word		0...255	min
V2	V2-d17	D.I. 7 activation indication delay time	34717	0	38395	12288	RW	Word		0...255	min
V2	V2-d18	D.I. 8 activation indication delay time	34718	0	38395	49152	RW	Word		0...255	min
V2	V2-01i	D.I. 9 activation indication delay time	34972	0	38405	3072	RW	Word		0...255	min/s
V2	V2-02i	D.I. 10 activation indication delay time	34973	0	38405	12288	RW	Word		0...255	min
V2	V2-H21	Configurability of digital output 1	34740	0	38396	3	RW	Word		0...19	num
V2	V2-H22	Configurability of digital output 2	34741	0	38396	12	RW	Word		0...19	num
V2	V2-H23	Configurability of digital output 3	34742	0	38396	48	RW	Word		0...19	num
V2	V2-H24	Configurability of digital output 4	34743	0	38396	192	RW	Word		0...19	num
V2	V2-H25	Configurability of digital output 5	34744	0	38396	768	RW	Word		0...19	num
V2	V2-H27	Configurability of digital output 7	34746	0	38396	12288	RW	Word		0...19	num
V2	V2-H29	Enable buzzer	34747	0	38396	49152	RW	Word		0...1	num
V2	V2-d01	Configurability of digital output 8	34963	0	38404	768	RW	Word		0...19	num
V2	V2-d02	Configurability of digital output 9	34964	0	38404	3072	RW	Word		0...19	num
V2	V2-H31	Configurability of the UP key	34938	0	38397	3	RW	Word		0...9	num
V2	V2-H32	Configurability of the DOWN key	34939	0	38397	12	RW	Word		0...9	num
V2	V2-H33	Configurability of the ESC key	34940	0	38397	48	RW	Word		0...9	num

V2	V2-H34	Configurability of the Free 1 key	34941	0	38397	192	RW	Word		0...9	num
V2	V2-H35	Configurability of the Free 2 key	34942	0	38397	768	RW	Word		0...9	num
V2	V2-H36	Configurability of the Free 3 key	34943	0	38397	3072	RW	Word		0...9	num
V2	V2-H37	Configurability of the Free 4 key	34944	0	38397	12288	RW	Word		0...9	num
V2	V2-H41	Analog input 1 calibration	34720	0	38397	49152	RW	Word		0...2	num
V2	V2-H42	Analog input 2 calibration	34721	0	38398	3	RW	Word		0...2	num
V2	V2-H43	Analog input 3 calibration	34722	0	38398	12	RW	Word		0...2	num
V2	V2-H44	Analog input 4 calibration	34723	0	38398	48	RW	Word		0...2	num
V2	V2-H45	Analog input 5 calibration	34724	0	38398	192	RW	Word		0...2	num
V2	V2-H46	Analog input 6 calibration	34725	0	38398	768	RW	Word		0...2	num
V2	V2-H47	Analog input 7 calibration	34726	0	38398	3072	RW	Word		0...2	num
V2	V2-H48	Analog input 8 calibration	34974	0	38405	49152	RW	Word		0...2	num
V2	V2-H50	Configurability of analog output 1	34748	0	38398	12288	RW	Word		0...1	num
V2	V2-H51	Function associated with analog output	34749	0	38398	49152	RW	Word		0...3	num
V2	V2-H68	RTC present	34750	0	38399	3	RW	Word		0...1	num
V2	V2-H70	Selection of 1st sensor for virtual probe	34728	0	38399	12	RW	Word		0...5	num
V2	V2-H71	Selection of 2nd sensor for virtual probe	34729	0	38399	48	RW	Word		0...5	num
V2	V2-H72	Day virtual probe calculation %	34730	0	38399	192	RW	Word		0...100	%
V2	V2-H73	Night virtual probe calculation %	34731	0	38399	768	RW	Word		0...100	%
V2	V2-H74	Selection of 1st sensor for filtered virtual probe	34960	0	38403	49152	RW	Word		0...65635	num
V2	V2-H75	Percentage in thousandths of the incoming signal for filtered virtual probe	34961	0	38404	3	RW	Word		0...6563.5	num
V2	V2-H76	Filtered virtual probe offset	34962	0	38404	12	RW	Word		0...6563.5	num
V2	V2-EtY	Selection of electronic expansion valve driver	34945	0	38399	3072	RW	Word		0...2	num
V2	V2-OHP	Selection of oil temperature probe	34952	0	38402	12288	RW	Word		0...8	num
V2	V2-OSP	Oil heater setpoint	34953	0	38402	49152	RW	Word	Y	V2-OLS...V2-OHS	°C/°F
V2	V2-OHd	Oil heater differential	34954	0	38403	3	RW	Word		.1...25.0	°C/°F
V2	V2-OHS	Maximum oil heater setpoint value that can be set	34956	0	38403	48	RW	Word	Y	V2-OLS...302.0	°C/°F
V2	V2-OLS	Minimum oil heater setpoint value that can be set	34957	0	38403	192	RW	Word	Y	-58.0...V2-OHS	°C/°F

V2	UL	Visibility of parameter transfer function (Device -> UNICARD/MFK)	-	-	38402	3	RW	Word		0...3	num
V2	dL	Visibility of parameter transfer function (UNICARD/MFK -> Device)	-	-	38402	12	RW	Word		0...3	num
V2	Fr	Visibility of UNICARD/MFK formatting function	-	-	38402	48	RW	Word		0...3	num

Application 3 parameters											
V3	V3-rE	Regulation type	35196	0	38464	3	RW	Word		0...6	num
V3	V3-rP1	Thermostat regulation probe 1	35197	0	38464	12	RW	Word		0...8	num
V3	V3-rP2	Thermostat regulation probe 2	35198	0	38464	48	RW	Word		0...9	num
V3	V3-SP1	Regulation setpoint 1	35199	0	38464	192	RW	Word	Y	V3-LS1...V3-HS1	°C/°F
V3	V3-dF1	Setpoint differential 1	35200	0	38464	768	RW	Word	Y	-58.0...302.0	°C/°F
V3	V3-SP2	Regulation setpoint 2	35201	0	38464	3072	RW	Word	Y	V3-LS2...V3-HS2	°C/°F
V3	V3-dF2	Setpoint differential 2	35202	0	38464	12288	RW	Word	Y	-58.0...302.0	°C/°F
V3	V3-Stt	Differential management mode	35205	0	38464	49152	RW	Word		0...1	num
V3	V3-HS1	Maximum value that can be set for Setpoint 1	35208	0	38465	3	RW	Word	Y	V3-LS1...V3-HdL	°C/°F
V3	V3-LS1	Minimum value that can be set for Setpoint 1	35209	0	38465	12	RW	Word	Y	V3-LdL...V3-HS1	°C/°F
V3	V3-HS2	Maximum value that can be set for Setpoint 2	35210	0	38465	48	RW	Word	Y	V3-LS2...V3-HdL	°C/°F
V3	V3-LS2	Minimum value that can be set for Setpoint 2	35211	0	38465	192	RW	Word	Y	V3-LdL...V3-HS2	°C/°F
V3	V3-HC1	Setpoint 1 operating mode (Heating/Cooling)	35206	0	38465	768	RW	Word		0...1	num
V3	V3-HC2	Setpoint 2 operating mode (Heating/Cooling)	35207	0	38465	3072	RW	Word		0...1	num
V3	V3-Cit	Minimum compressor output activation time	35216	0	38465	49152	RW	Word		0...250	min
V3	V3-CAt	Maximum compressor output activation time	35217	0	38466	3	RW	Word		0...250	min
V3	V3-Ont	Compressor output ON time if regulation probe is faulty	35222	0	38466	12	RW	Word		0...250	min
V3	V3-OFt	Compressor output OFF time if regulation probe is faulty	35223	0	38466	48	RW	Word		0...250	min
V3	V3-dOn	Compressor output activation delay from call	35218	0	38466	192	RW	Word		0...250	s
V3	V3-dOF	Compressor output activation delay from switch-off	35219	0	38466	768	RW	Word		0...250	min
V3	V3-dbi	Delay between two consecutive compressor output power-ons	35220	0	38466	3072	RW	Word		0...250	min

V3	V3-OdO	Output activation delay at startup	35221	0	38466	12288	RW	Word		0...250	min
V3	V3-CFP	Condenser pre-ventilation time in Heat/Cool	35305	0	38467	12	RW	Word		0...255	s
V3	V3-CFd	Condenser fan cut-out during defrosting.	35306	0	38467	48	RW	Word		0...1	num
V3	V3-OF1	Remote offset	35227	0	38467	192	RW	Word	Y	-50.0...50.0	°C/°F
V3	V3-Pot	Pump down time	35333	0	38498	192	RW	Word		0...250	s
V3	V3-SS1	Compressor softstart: advance hotgas valve opening	35334	0	38498	768	RW	Word		0...250	s
V3	V3-SS2	Compressor softstart: delay hotgas valve closing	35335	0	38498	3072	RW	Word		0...250	s
V3	V3-dP1	Select defrost probe 1	35228	0	38467	768	RW	Word		0...8	num
V3	V3-dP2	Defrost probe 2 selection	35229	0	38467	3072	RW	Word		0...8	num
V3	V3-dtY	Type of defrost	35232	0	38467	12288	RW	Word		0...4	num
V3	V3-dFt	Dual evaporator defrost activation mode	35230	0	38467	49152	RW	Word		0...2	num
V3	V3-dit	Interval between defrosts	35233	0	38468	3	RW	Word		0...250	h/min/s
V3	V3-dt1	Unit of measure for defrost intervals	35236	0	38468	12	RW	Word		0...2	num
V3	V3-dt2	Unit of measure for defrost duration	35237	0	38468	48	RW	Word		0...2	num
V3	V3-dCt	Defrost interval count mode	35231	0	38468	192	RW	Word		0...5	num
V3	V3-dOH	Defrost cycle activation delay from the call	35238	0	38468	768	RW	Word		0...250	min
V3	V3-dE1	Evaporator 1 defrost maximum duration	35234	0	38468	3072	RW	Word		1...250	h/min/s
V3	V3-dE2	Evaporator 2 defrost maximum duration	35235	0	38468	12288	RW	Word		1...250	h/min/s
V3	V3-dS1	Evaporator 1 defrost end temperature	35240	0	38468	49152	RW	Word	Y	-58.0...302.0	°C/°F
V3	V3-dS2	Evaporator 2 defrost end temperature	35241	0	38469	3	RW	Word	Y	-58.0...302.0	°C/°F
V3	V3-dSS	Temperature threshold for starting defrost	35239	0	38469	12	RW	Word	Y	-58.0...302.0	°C/°F
V3	V3-dPO	Defrost activation request at power-on	35242	0	38469	48	RW	Word		0...1	num
V3	V3-tcd	Compressor output activation/deactivation time before a defrost	35243	0	38469	192	RW	Word	Y	-60...60	min
V3	V3-ndE	minimum defrost duration time	35244	0	38469	768	RW	Word		0...250	h/min/s
V3	V3-PdC	Hot gas extraction time at the end of the defrost	35245	0	38469	3072	RW	Word		0...250	min
V3	V3-tPd	Pump down time before defrost start	35247	0	38469	12288	RW	Word		0...255	min
V3	V3-dPH	Regular defrost start hour	35186	0	38469	49152	RW	Word		0...24	h
V3	V3-dPn	Regular defrost start minutes	35187	0	38470	3	RW	Word		0...59	min
V3	V3-dPd	Regular defrost interval duration	35188	0	38470	12	RW	Word		1...7	day

V3	V3-Fd1	1st weekend/holiday day	35135	0	38470	48	RW	Word		0...7	num
V3	V3-Fd2	2nd weekend/holiday day	35136	0	38470	192	RW	Word		0...7	num
V3	V3-Edt	Timeout and defrost end temperature specific to each event	35137	0	38470	768	RW	Word		0...1	num
V3	V3-PrH	Basin heater pre-activation time	35342	0	38499	3072	RW	Word		0...255	min
V3	V3-Fdn	Weekday defrost number	35085	0	38504	3	RW	Word		0...250	num
V3	V3-FFn	Weekend/holiday defrost number	35086	0	38504	12	RW	Word		0...250	num
V3	V3-d1H	Weekday defrost no. 1 start hour	35138	0	38470	3072	RW	Word		0...24	h
V3	V3-d1n	Weekday defrost no. 1 start minute	35139	0	38470	12288	RW	Word		0...59	min
V3	V3-d1t	1st weekday defrost duration	35140	0	38470	49152	RW	Word		0...250	min
V3	V3-d1S	1st weekday defrost end temperature	35141	0	38471	3	RW	Word	Y	-58.0...302.0	°C/°F
V3	V3-d2H	Weekday defrost no. 2 start hour	35142	0	38471	12	RW	Word		V3-d1H...24	h
V3	V3-d2n	Weekday defrost no. 2 start minutes	35143	0	38471	48	RW	Word		0...59	min
V3	V3-d2t	2nd weekday defrost duration	35144	0	38471	192	RW	Word		0...250	min
V3	V3-d2S	2nd weekday defrost end temperature	35145	0	38471	768	RW	Word	Y	-58.0...302.0	°C/°F
V3	V3-d3H	Weekday defrost no. 3 start hour	35146	0	38471	3072	RW	Word		V3-d2H...24	h
V3	V3-d3n	Weekday defrost no. 3 start minutes	35147	0	38471	12288	RW	Word		0...59	min
V3	V3-d3t	3rd weekday defrost duration	35148	0	38471	49152	RW	Word		0...250	min
V3	V3-d3S	3rd weekday defrost end temperature	35149	0	38472	3	RW	Word	Y	-58.0...302.0	°C/°F
V3	V3-d4H	Weekday defrost no. 4 start hour	35150	0	38472	12	RW	Word		V3-d3H...24	h
V3	V3-d4n	Weekday defrost no. 4 start minutes	35151	0	38472	48	RW	Word		0...59	min
V3	V3-d4t	4th weekday defrost duration	35152	0	38472	192	RW	Word		0...250	min
V3	V3-d4S	4th weekday defrost end temperature	35153	0	38472	768	RW	Word	Y	-58.0...302.0	°C/°F
V3	V3-d5H	Weekday defrost no. 5 start hour	35154	0	38472	3072	RW	Word		V3-d4H...24	h
V3	V3-d5n	Weekday defrost no. 5 start minutes	35155	0	38472	12288	RW	Word		0...59	min
V3	V3-d5t	5th weekday defrost duration	35156	0	38472	49152	RW	Word		0...250	min
V3	V3-d5S	5th weekday defrost end temperature	35157	0	38473	3	RW	Word	Y	-58.0...302.0	°C/°F
V3	V3-d6H	Weekday defrost no. 6 start hour	35158	0	38473	12	RW	Word		V3-d5H...24	h
V3	V3-d6n	Weekday defrost no. 6 start minutes	35159	0	38473	48	RW	Word		0...59	min
V3	V3-d6t	6th weekday defrost duration	35160	0	38473	192	RW	Word		0...250	min
V3	V3-d6S	6th weekday defrost end temperature	35161	0	38473	768	RW	Word	Y	-58.0...302.0	°C/°F

V3	V3-F1H	Weekend/holiday defrost no. 1 start hour	35162	0	38473	3072	RW	Word		0...24	h
V3	V3-F1n	Weekend/holiday defrost no. 1 start minute	35163	0	38473	12288	RW	Word		0...59	min
V3	V3-F1t	1st weekend/holiday defrost duration	35164	0	38473	49152	RW	Word		0...250	min
V3	V3-F1S	1st weekend/holiday defrost end temperature	35165	0	38474	3	RW	Word	Y	-58.0...302.0	°C/°F
V3	V3-F2H	Weekend/holiday defrost no. 2 start hour	35166	0	38474	12	RW	Word		V3-F1H...24	h
V3	V3-F2n	Weekend/holiday defrost no. 2 start minutes	35167	0	38474	48	RW	Word		0...59	min
V3	V3-F2t	2nd weekend/holiday defrost duration	35168	0	38474	192	RW	Word		0...250	min
V3	V3-F2S	2nd weekend/holiday defrost end temperature	35169	0	38474	768	RW	Word	Y	-58.0...302.0	°C/°F
V3	V3-F3H	Weekend/holiday defrost no. 3 start hour	35170	0	38474	3072	RW	Word		V3-F2H...24	h
V3	V3-F3n	Weekend/holiday defrost no. 3 start minutes	35171	0	38474	12288	RW	Word		0...59	min
V3	V3-F3t	3rd weekend/holiday defrost duration	35172	0	38474	49152	RW	Word		0...250	min
V3	V3-F3S	3rd weekend/holiday defrost end temperature	35173	0	38475	3	RW	Word	Y	-58.0...302.0	°C/°F
V3	V3-F4H	Weekend/holiday defrost no. 4 start hour	35174	0	38475	12	RW	Word		V3-F3H...24	h
V3	V3-F4n	Weekend/holiday defrost no. 4 start minutes	35175	0	38475	48	RW	Word		0...59	min
V3	V3-F4t	4th weekend/holiday defrost duration	35176	0	38475	192	RW	Word		0...250	min
V3	V3-F4S	4th weekend/holiday defrost end temperature	35177	0	38475	768	RW	Word	Y	-58.0...302.0	°C/°F
V3	V3-F5H	Weekend/holiday defrost no. 5 start hour	35178	0	38475	3072	RW	Word		V3-F4H...24	h
V3	V3-F5n	Weekend/holiday defrost no. 5 start minutes	35179	0	38475	12288	RW	Word		0...59	min
V3	V3-F5t	5th weekend/holiday defrost duration	35180	0	38475	49152	RW	Word		0...250	min
V3	V3-F5S	5th weekend/holiday defrost end temperature	35181	0	38476	3	RW	Word	Y	-58.0...302.0	°C/°F
V3	V3-F6H	Weekend/holiday defrost no. 6 start hour	35182	0	38476	12	RW	Word		V3-F5H...24	h
V3	V3-F6n	Weekend/holiday defrost no. 6 start minutes	35183	0	38476	48	RW	Word		0...59	min
V3	V3-F6t	6th weekend/holiday defrost duration	35184	0	38476	192	RW	Word		0...250	min

V3	V3-F6S	6th weekend/holiday defrost end temperature	35185	0	38476	768	RW	Word	Y	-58.0...302.0	°C/°F
V3	V3-FP1	Selection of evaporator fan probe in normal mode	35248	0	38476	3072	RW	Word		0...7	num
V3	V3-FP2	Selection of evaporator fan probe in defrost	35249	0	38476	12288	RW	Word		0...7	num
V3	V3-FPt	FSt parameter mode (absolute or relative)	35250	0	38476	49152	RW	Word		0...1	num
V3	V3-FSt	Evaporator fan disabling temperature	35251	0	38477	3	RW	Word	Y	-58.0...302.0	°C/°F
V3	V3-FAd	Evaporator fan trigger differential	35252	0	38477	12	RW	Word		.1...25.0	°C/°F
V3	V3-Fdt	Evaporator fan activation delay time after a defrost cycle	35253	0	38477	48	RW	Word		0...250	min
V3	V3-dt	Dripping time	35258	0	38477	192	RW	Word		0...250	min
V3	V3-dFd	Evaporator fan cut-out during defrost	35256	0	38477	768	RW	Word		0...1	num
V3	V3-FCO	Evaporator fan status with compressor output Off	35255	0	38477	3072	RW	Word		0...4	num
V3	V3-Fod	Evaporator fan status with door open	35257	0	38477	12288	RW	Word		0...1	num
V3	V3-FdC	Evaporator fan shutoff delay after compressor deactivation	35254	0	38477	49152	RW	Word		0...250	min
V3	V3-Fon	Evaporator fan On time in cyclical regulator mode	35259	0	38478	3	RW	Word		0...250	min
V3	V3-FOF	Evaporator fan Off time in cyclical regulator mode	35260	0	38478	12	RW	Word		0...250	min
V3	V3-Fnn	Evaporator fan ON time in night mode (duty cycle)	35261	0	38478	48	RW	Word		0...250	min
V3	V3-FnF	Evaporator fan OFF time in night mode (duty cycle)	35262	0	38478	192	RW	Word		0...250	min
V3	V3-FE1	Variable speed fan probe selection	35361	0	38502	48	RW	Word		0...12	num
V3	V3-FEt	Setpoint mode	35362	0	38502	192	RW	Word		0...1	num
V3	V3-FES	Setpoint	35363	0	38502	768	RW	Word	Y	-58...302	num
V3	V3-FEd	Band	35364	0	38502	3072	RW	Word		0.1...50	num
V3	V3-FEu	Cut-off band	35365	0	38502	12288	RW	Word		0...25	num
V3	V3-FEC	Cut-off differential	35366	0	38502	49152	RW	Word		0.1...25	num
V3	V3-FEr	Fan shutoff delay after compressor deactivation	35367	0	38503	3	RW	Word		0...250	min
V3	V3-FE2	Minimum day percentage	35368	0	38503	12	RW	Word		0...100	%
V3	V3-FE3	Maximum day percentage with compressor on	35369	0	38503	48	RW	Word		0...100	%
V3	V3-FE4	Maximum day percentage with compressor off	35370	0	38503	192	RW	Word		0...100	%
V3	V3-FE5	Minimum night percentage	35371	0	38503	768	RW	Word		0...100	%

V3	V3-FE6	Maximum night percentage with compressor on	35372	0	38503	3072	RW	Word		0...100	%
V3	V3-FE7	Maximum night percentage with compressor off	35373	0	38503	12288	RW	Word		0...100	%
V3	V3-FE8	Percentage during defrost	35374	0	38503	49152	RW	Word		0...100	%
V3	V3-FE9	Percentage in the event of probe error	35375	0	38515	12	RW	Word		0...100	%
V3	V3-FEA	Maximum pick-up speed	35376	0	38515	48	RW	Word		0...100	%
V3	V3-FEB	Fan pick-up time	35377	0	38515	192	RW	Word		0...250	s
V3	V3-FEP	Fan forcing period at pick-up speed	35378	0	38515	768	RW	Word		0...250	min
V3	V3-rA1	Temperature alarm probe 1 selection	35276	0	38478	768	RW	Word		0...7	num
V3	V3-rA2	Temperature alarm probe 2 selection	35277	0	38478	3072	RW	Word		0...7	num
V3	V3-Att	Alarm mode (absolute or relative)	35278	0	38478	12288	RW	Word		0...1	num
V3	V3-AFd	Alarm activation differential	35279	0	38478	49152	RW	Word		.1...25.0	°C/°F
V3	V3-HA1	Maximum alarm 1 threshold	35280	0	38479	3	RW	Word	Y	V3-LA1...302.0	°C/°F
V3	V3-LA1	Minimum alarm 1 threshold	35281	0	38479	12	RW	Word	Y	-58.0...V3-HA1	°C/°F
V3	V3-HA2	Maximum alarm 2 threshold	35282	0	38479	48	RW	Word	Y	V3-LA2...302.0	°C/°F
V3	V3-LA2	Minimum alarm 2 threshold	35283	0	38479	192	RW	Word	Y	-58.0...V3-HA2	°C/°F
V3	V3-PAO	Temperature alarm exclusion time from power-on	35284	0	38479	768	RW	Word		0...10	h
V3	V3-dAO	Exclusion time for temperature alarms after a defrost cycle	35286	0	38479	3072	RW	Word		0...250	min
V3	V3-OAO	High and low temperature alarms exclusion time after closing the door	35285	0	38479	12288	RW	Word		0...10	h
V3	V3-tdO	Door open alarm exclusion time	35330	0	38479	49152	RW	Word		0...250	num
V3	V3-tA1	Probe 1 High/Minimum Alarm Delay	35287	0	38480	3	RW	Word		0...250	min
V3	V3-tA2	Probe 2 High/Minimum Alarm Delay	35288	0	38480	12	RW	Word		0...250	min
V3	V3-dAt	Defrost ended due to timeout alarm signaling	35246	0	38480	48	RW	Word		0...1	num
V3	V3-EAL	Regulators inhibited by external alarm	35290	0	38480	192	RW	Word		0...2	num
V3	V3-rA3	Leak detection probe selection	35349	0	38500	12288	RW	Word		0...8	num
V3	V3-ALL	Low threshold leak alarm	35350	0	38500	49152	RW	Word		0...V3-ALH	num
V3	V3-ALH	High threshold leak alarm	35351	0	38501	3	RW	Word		V3-ALL...100	num
V3	V3-dAL	Alarm leak differential	35352	0	38501	12	RW	Word		0.1...100	num

V3	V3-AL1	Time probe remains above the low threshold due to leak alarm activation	35353	0	38501	48	RW	Word		0...250	min
V3	V3-AL2	Time probe remains above the high threshold due to leak alarm activation	35360	0	38502	12	RW	Word		0...250	min
V3	V3-tP	Enables alarm acknowledgment with any key	35331	0	38480	768	RW	Word		0...1	num
V3	V3-Art	Regular watchdog alarm activation period	35275	0	38480	3072	RW	Word		0...250	min*10
V3	V3-dSd	Enable light relay from door switch	35272	0	38480	12288	RW	Word		0...1	num
V3	V3-dLt	Light relay off delay from door closure	35273	0	38480	49152	RW	Word		0...250	min
V3	V3-OFL	Enable cold room lights off via key during the delay set in parameter dLt	35274	0	38481	3	RW	Word		0...1	num
V3	V3-dOd	Enable utility shutoff upon door switch activation	35289	0	38481	12	RW	Word		0...3	num
V3	V3-dOA	Behavior forced by digital input	35291	0	38481	48	RW	Word		0...5	num
V3	V3-PEA	Enable forced behavior from door switch and/or external alarm.	35292	0	38481	192	RW	Word		0...3	num
V3	V3-dCO	Compressor activation delay from acknowledgment	35293	0	38481	768	RW	Word		0...250	min
V3	V3-dFO	Fan enabling delay from acknowledgment	35294	0	38481	3072	RW	Word		0...250	min
V3	V3-ASb	Instrument off active light/auxiliary digital input or key	35320	0	38481	12288	RW	Word		0...1	num
V3	V3-L00	Shared probe	35072	0	38481	49152	RW	Word		0...7	num
V3	V3-L01	Distributed viewing (refers to slave)	35073	0	38482	3	RW	Word		0...2	num
V3	V3-L02	Setpoint synchronization	35074	0	38482	12	RW	Word		0...1	num
V3	V3-L03	Defrost synchronization	35075	0	38482	48	RW	Word		0...2	num
V3	V3-L04	Inhibit resources at the end of defrost	35076	0	38482	192	RW	Word		0...1	num
V3	V3-L05	Stand-by synchronization	35077	0	38482	768	RW	Word		0...1	num
V3	V3-L06	Lights synchronization	35078	0	38482	3072	RW	Word		0...1	num
V3	V3-L07	Reduced set synchronization	35079	0	38482	12288	RW	Word		0...1	num
V3	V3-L08	AUX synchronization	35080	0	38482	49152	RW	Word		0...1	num
V3	V3-L09	Shared saturation probe	35081	0	38483	3	RW	Word		0...1	num
V3	V3-L10	Resource unlocking timeout during synchronized defrosts	35332	0	38483	12	RW	Word		0...250	min
V3	V3-L11	Number of devices connected in Link2	35082	0	38500	48	RW	Word		0...8	num
V3	V3-L12	Alarm relay sharing in Link2	35083	0	38500	192	RW	Word		0...2	num

V3	V3-L13	Link2 serial frame configuration	35343	0	38499	12288	RW	Word		0...2	num
V3	V3-L14	Force cool mode	35359	0	38502	3	RW	Word		0...1	num
V3	V3-dcS	Deep cooling setpoint	35266	0	38483	768	RW	Word	Y	-58.0...302.0	°C/°F
V3	V3-tdc	Deep cooling duration	35267	0	38483	3072	RW	Word		0...250	min
V3	V3-dcc	Defrost delay after deep cooling	35268	0	38483	12288	RW	Word		0...250	min
V3	V3-ESst	Type of action for the Energy Saving function	35195	0	38483	49152	RW	Word		0...8	num
V3	V3-ESF	Night mode activation (Energy Saving)	35263	0	38484	3	RW	Word		0...1	num
V3	V3-Cdt	Door closing time	35264	0	38484	12	RW	Word		0...255	min*10
V3	V3-ESo	Low consumption mode disabling timeout (door switch)	35265	0	38484	48	RW	Word		0...10	num
V3	V3-OS1	Offset on setpoint 1	35212	0	38484	192	RW	Word	Y	-50.0...50.0	°C/°F
V3	V3-OS2	Offset on setpoint 2	35213	0	38484	768	RW	Word	Y	-50.0...50.0	°C/°F
V3	V3-Od1	Refrigerated cabinets energy saving offset 1	35214	0	38484	3072	RW	Word	Y	-50.0...50.0	°C/°F
V3	V3-Od2	Refrigerated cabinets energy saving offset 2	35215	0	38484	12288	RW	Word	Y	-50.0...50.0	°C/°F
V3	V3-dn1	Differential during energy saving mode 1	35203	0	38484	49152	RW	Word	Y	-58.0...302.0	°C/°F
V3	V3-dn2	Differential during energy saving mode 2	35204	0	38485	3	RW	Word	Y	-58.0...302.0	°C/°F
V3	V3-EdH	Weekday energy saving start hour	35189	0	38485	12	RW	Word		0...24	h
V3	V3-Edn	Weekday energy saving start minutes	35190	0	38485	48	RW	Word		0...59	min
V3	V3-Edd	Weekday energy saving duration	35191	0	38485	192	RW	Word		1...72	h
V3	V3-EFH	Weekend/holiday energy saving start hour	35192	0	38485	768	RW	Word		0...24	h
V3	V3-EFn	Weekend/holiday energy saving start minutes	35193	0	38485	3072	RW	Word		0...59	min
V3	V3-EFd	Weekend/holiday energy saving duration	35194	0	38485	12288	RW	Word		1...72	h
V3	V3-FH	Frame heater probe selection	35295	0	38485	49152	RW	Word		0...9	num
V3	V3-FHt	Frame heater period	35297	0	38486	3	RW	Word		1...2500	s
V3	V3-FH0	Frame heater set	35298	0	38486	12	RW	Word	Y	-58.0...302.0	°C/°F
V3	V3-FH1	Frame heater offset	35299	0	38486	48	RW	Word		0...25.0	°C/°F
V3	V3-FH2	Frame heater band	35300	0	38486	192	RW	Word	Y	-58.0...302.0	°C/°F
V3	V3-FH3	Frame heater minimum percentage/duty-cycle	35301	0	38486	768	RW	Word		0...100	%
V3	V3-FH4	Frame heater maximum percentage/day duty-cycle	35302	0	38486	3072	RW	Word		0...100	%
V3	V3-FH5	Frame heater maximum percentage/night duty-cycle	35303	0	38486	12288	RW	Word		0...100	%
V3	V3-FH6	Frame heater percentage/duty-cycle in defrost	35304	0	38486	49152	RW	Word		0...100	%

V3	V3-LOC	Disable terminal	35307	0	38487	3	RW	Word		0...1	num
V3	V3-PS1	Password 1 value	35308	0	38487	12	RW	Word		0...250	num
V3	V3-PS2	Password 2 value	35309	0	38487	48	RW	Word		0...250	num
V3	V3-ndt	Display with decimal point	35310	0	38487	192	RW	Word		0...1	num
V3	V3-CA1	Analog input 1 calibration	35116	0	38487	768	RW	Word	Y	-30.0...30.0	°C/°F
V3	V3-CA2	Analog input 2 calibration	35117	0	38487	3072	RW	Word	Y	-30.0...30.0	°C/°F
V3	V3-CA3	Analog input 3 calibration	35118	0	38487	12288	RW	Word	Y	-30.0...30.0	°C/°F
V3	V3-CA4	Analog input 4 calibration	35119	0	38487	49152	RW	Word	Y	-30.0...30.0	°C/°F
V3	V3-CA5	Analog input 5 calibration	35120	0	38488	3	RW	Word	Y	-30.0...30.0	°C/°F
V3	V3-CA6	Analog input 6 calibration	35121	0	38488	12	RW	Word	Y	-30...30	bar/psi
V3	V3-CA7	Analog input 7 calibration	35122	0	38488	48	RW	Word	Y	-30...30	bar/psi
V3	V3-LdL	Minimum display value	35311	0	38488	192	RW	Word	Y	-58.0...V3-HdL	°C/°F
V3	V3-HdL	Maximum display value	35312	0	38488	768	RW	Word	Y	V3-LdL...302.0	°C/°F
V3	V3-ddL	Display lock mode during a defrost	35313	0	38488	3072	RW	Word		0...2	num
V3	V3-Ldd	Display lock timeout from end of defrost	35314	0	38488	12288	RW	Word		0...250	min
V3	V3-dro	Select °C / °F	35315	0	38488	49152	RW	Word		0...1	num
V3	V3-SbP	Pressure unit of measure	35316	0	38489	3	RW	Word		0...1	num
V3	V3-ddd	Select main display value	35317	0	38489	12	RW	Word		0...8	num
V3	V3-ddE	Resource displayed on ECHO	35318	0	38489	48	RW	Word		0...9	num
V3	V3-rPH	Receiver maximum valve opening %	35269	0	38489	192	RW	Word		0...5	num
V3	V3-H00	Select analog input type NTC/PTC	35084	0	38489	768	RW	Word		0...2	num
V3	V3-H02	Function activation time from terminal	35319	0	38489	3072	RW	Word		0...250	s
V3	V3-H08	Stand-by operating mode	35321	0	38489	12288	RW	Word		0...2	num
V3	V3-H11	Digital input 1 configurability and polarity	35087	0	38489	49152	RW	Word	Y	-18...18	num
V3	V3-H12	Digital input 2 configurability and polarity	35088	0	38490	3	RW	Word	Y	-18...18	num
V3	V3-H13	Digital input 3 configurability and polarity	35089	0	38490	12	RW	Word	Y	-18...18	num
V3	V3-H14	Digital input 4 configurability and polarity	35090	0	38490	48	RW	Word	Y	-18...18	num
V3	V3-H15	Digital input 5 configurability and polarity	35091	0	38490	192	RW	Word	Y	-18...18	num
V3	V3-H16	Digital input 6 configurability and polarity	35092	0	38490	768	RW	Word	Y	-18...18	num

V3	V3-H17	Digital input 7 configurability and polarity	35093	0	38490	3072	RW	Word	Y	-18...18	num
V3	V3-H18	Digital input 8 configurability and polarity	35094	0	38490	12288	RW	Word	Y	-18...18	num
V3	V3-i01	Digital input 9 configurability and polarity	35354	0	38501	192	RW	Word	Y	-18...18	num
V3	V3-i02	D.I. 10 activation indication delay time	35355	0	38501	768	RW	Word	Y	-18...18	num
V3	V3-dti	Digital inputs 1 and 2 delay unit of measure	35103	0	38490	49152	RW	Word		0...1	num
V3	V3-d11	D.I. 1 activation indication delay time	35095	0	38491	3	RW	Word		0...255	min/s
V3	V3-d12	D.I. 2 activation indication delay time	35096	0	38491	12	RW	Word		0...255	min/s
V3	V3-d13	D.I. 3 activation indication delay time	35097	0	38491	48	RW	Word		0...255	min
V3	V3-d14	D.I. 4 activation indication delay time	35098	0	38491	192	RW	Word		0...255	min
V3	V3-d15	D.I. 5 activation indication delay time	35099	0	38491	768	RW	Word		0...255	min
V3	V3-d16	D.I. 6 activation indication delay time	35100	0	38491	3072	RW	Word		0...255	min
V3	V3-d17	D.I. 7 activation indication delay time	35101	0	38491	12288	RW	Word		0...255	min
V3	V3-d18	D.I. 8 activation indication delay time	35102	0	38491	49152	RW	Word		0...255	min
V3	V3-01i	D.I. 9 activation indication delay time	35356	0	38501	3072	RW	Word		0...255	min/s
V3	V3-02i	D.I. 10 activation indication delay time	35357	0	38501	12288	RW	Word		0...255	min
V3	V3-H21	Configurability of digital output 1	35124	0	38492	3	RW	Word		0...19	num
V3	V3-H22	Configurability of digital output 2	35125	0	38492	12	RW	Word		0...19	num
V3	V3-H23	Configurability of digital output 3	35126	0	38492	48	RW	Word		0...19	num
V3	V3-H24	Configurability of digital output 4	35127	0	38492	192	RW	Word		0...19	num
V3	V3-H25	Configurability of digital output 5	35128	0	38492	768	RW	Word		0...19	num
V3	V3-H27	Configurability of digital output 7	35130	0	38492	12288	RW	Word		0...19	num
V3	V3-H29	Enable buzzer	35131	0	38492	49152	RW	Word		0...1	num
V3	V3-d01	Configurability of digital output 8	35347	0	38500	768	RW	Word		0...19	num
V3	V3-d02	Configurability of digital output 9	35348	0	38500	3072	RW	Word		0...19	num
V3	V3-H31	Configurability of the UP key	35322	0	38493	3	RW	Word		0...9	num
V3	V3-H32	Configurability of the DOWN key	35323	0	38493	12	RW	Word		0...9	num
V3	V3-H33	Configurability of the ESC key	35324	0	38493	48	RW	Word		0...9	num
V3	V3-H34	Configurability of the Free 1 key	35325	0	38493	192	RW	Word		0...9	num
V3	V3-H35	Configurability of the Free 2 key	35326	0	38493	768	RW	Word		0...9	num
V3	V3-H36	Configurability of the Free 3 key	35327	0	38493	3072	RW	Word		0...9	num

V3	V3-H37	Configurability of the Free 4 key	35328	0	38493	12288	RW	Word		0...9	num
V3	V3-H41	Analog input 1 calibration	35104	0	38493	49152	RW	Word		0...2	num
V3	V3-H42	Analog input 2 calibration	35105	0	38494	3	RW	Word		0...2	num
V3	V3-H43	Analog input 3 calibration	35106	0	38494	12	RW	Word		0...2	num
V3	V3-H44	Analog input 4 calibration	35107	0	38494	48	RW	Word		0...2	num
V3	V3-H45	Analog input 5 calibration	35108	0	38494	192	RW	Word		0...2	num
V3	V3-H46	Analog input 6 calibration	35109	0	38494	768	RW	Word		0...2	num
V3	V3-H47	Analog input 7 calibration	35110	0	38494	3072	RW	Word		0...2	num
V3	V3-H48	Analog input 8 calibration	35358	0	38501	49152	RW	Word		0...2	num
V3	V3-H50	Configurability of analog output 1	35132	0	38494	12288	RW	Word		0...1	num
V3	V3-H51	Function associated with analog output	35133	0	38494	49152	RW	Word		0...3	num
V3	V3-H68	RTC present	35134	0	38495	3	RW	Word		0...1	num
V3	V3-H70	Selection of 1st sensor for virtual probe	35112	0	38495	12	RW	Word		0...5	num
V3	V3-H71	Selection of 2nd sensor for virtual probe	35113	0	38495	48	RW	Word		0...5	num
V3	V3-H72	Day virtual probe calculation %	35114	0	38495	192	RW	Word		0...100	%
V3	V3-H73	Night virtual probe calculation %	35115	0	38495	768	RW	Word		0...100	%
V3	V3-H74	Selection of 1st sensor for filtered virtual probe	35343	0	38499	49152	RW	Word		0...65635	num
V3	V3-H75	Percentage in thousandths of the incoming signal for filtered virtual probe	35344	0	38500	3	RW	Word		0...6563.5	num
V3	V3-H76	Filtered virtual probe offset	35346	0	38500	12	RW	Word		0...6563.5	num
V3	V3-EtY	Selection of electronic expansion valve driver	35329	0	38495	3072	RW	Word		0...2	num
V3	V3-OHP	Selection of oil temperature probe	35336	0	38498	12288	RW	Word		0...8	num
V3	V3-OSP	Oil heater setpoint	35337	0	38498	49152	RW	Word	Y	V3-OLS...V3-OHS	°C/°F
V3	V3-OHd	Oil heater differential	35338	0	38499	3	RW	Word		.1...25.0	°C/°F
V3	V3-OHS	Maximum oil heater setpoint value that can be set	35340	0	38499	48	RW	Word	Y	V3-OLS...302.0	°C/°F
V3	V3-OLS	Minimum oil heater setpoint value that can be set	35341	0	38499	192	RW	Word	Y	-58.0...V3-OHS	°C/°F
V3	UL	Visibility of parameter transfer function (Device -> UNICARD/MFK)	-	-	38498	3	RW	Word		0...3	num
V3	dL	Visibility of parameter transfer function (UNICARD/MFK -> Device)	-	-	38498	12	RW	Word		0...3	num
V3	Fr	Visibility of UNICARD/MFK formatting function	-	-	38498	48	RW	Word		0...3	num

Application 4 parameters											
V4	V4-rE	Regulation type	35580	0	38560	3	RW	Word		0...6	num
V4	V4-rP1	Thermostat regulation probe 1	35581	0	38560	12	RW	Word		0...8	num
V4	V4-rP2	Thermostat regulation probe 2	35582	0	38560	48	RW	Word		0...9	num
V4	V4-SP1	Regulation setpoint 1	35583	0	38560	192	RW	Word	Y	V4-LS1...V4-HS1	°C/°F
V4	V4-dF1	Setpoint differential 1	35584	0	38560	768	RW	Word	Y	-58.0...302.0	°C/°F
V4	V4-SP2	Regulation setpoint 2	35585	0	38560	3072	RW	Word	Y	V4-LS2...V4-HS2	°C/°F
V4	V4-dF2	Setpoint differential 2	35586	0	38560	12288	RW	Word	Y	-58.0...302.0	°C/°F
V4	V4-Stt	Differential management mode	35589	0	38560	49152	RW	Word		0...1	num
V4	V4-HS1	Maximum value that can be set for Setpoint 1	35592	0	38561	3	RW	Word	Y	V4-LS1...V4-HdL	°C/°F
V4	V4-LS1	Minimum value that can be set for Setpoint 1	35593	0	38561	12	RW	Word	Y	V4-LdL...V4-HS1	°C/°F
V4	V4-HS2	Maximum value that can be set for Setpoint 2	35594	0	38561	48	RW	Word	Y	V4-LS2...V4-HdL	°C/°F
V4	V4-LS2	Minimum value that can be set for Setpoint 2	35595	0	38561	192	RW	Word	Y	V4-LdL...V4-HS2	°C/°F
V4	V4-HC1	Setpoint 1 operating mode (Heating/Cooling)	35590	0	38561	768	RW	Word		0...1	num
V4	V4-HC2	Setpoint 2 operating mode (Heating/Cooling)	35591	0	38561	3072	RW	Word		0...1	num
V4	V4-Cit	Minimum compressor output activation time	35600	0	38562	12	RW	Word		0...250	min
V4	V4-CAt	Maximum compressor output activation time	35601	0	38562	48	RW	Word		0...250	min
V4	V4-Ont	Compressor output ON time if regulation probe is faulty	35606	0	38561	49152	RW	Word		0...250	min
V4	V4-OFt	Compressor output OFF time if regulation probe is faulty	35607	0	38562	3	RW	Word		0...250	min
V4	V4-dOn	Compressor output activation delay from call	35602	0	38562	192	RW	Word		0...250	s
V4	V4-dOF	Compressor output activation delay from switch-off	35603	0	38562	768	RW	Word		0...250	min
V4	V4-dbi	Delay between two consecutive compressor output power-ons	35604	0	38562	3072	RW	Word		0...250	min
V4	V4-OdO	Output activation delay at startup	35605	0	38562	12288	RW	Word		0...250	min
V4	V4-CFP	Condenser pre-ventilation time in Heat/Cool	35689	0	38563	12	RW	Word		0...255	s
V4	V4-CFd	Condenser fan cut-out during defrosting.	35690	0	38563	48	RW	Word		0...1	num
V4	V4-OF1	Remote offset	35611	0	38563	192	RW	Word	Y	-50.0...50.0	°C/°F
V4	V4-Pot	Pump down time	35717	0	38594	192	RW	Word		0...250	s
V4	V4-SS1	Compressor softstart: advance hotgas valve opening	35718	0	38594	768	RW	Word		0...250	s

V4	V4-SS2	Compressor softstart: delay hotgas valve closing	35719	0	38594	3072	RW	Word		0...250	s
V4	V4-dP1	Select defrost probe 1	35612	0	38563	768	RW	Word		0...8	num
V4	V4-dP2	Defrost probe 2 selection	35613	0	38563	3072	RW	Word		0...8	num
V4	V4-dtY	Type of defrost	35616	0	38563	12288	RW	Word		0...4	num
V4	V4-dFt	Dual evaporator defrost activation mode	35614	0	38563	49152	RW	Word		0...2	num
V4	V4-dit	Interval between defrosts	35617	0	38564	768	RW	Word		0...250	h/min/s
V4	V4-dt1	Unit of measure for defrost intervals	35620	0	38564	3	RW	Word		0...2	num
V4	V4-dt2	Unit of measure for defrost duration	35621	0	38564	12	RW	Word		0...2	num
V4	V4-dCt	Defrost interval count mode	35615	0	38564	48	RW	Word		0...5	num
V4	V4-dOH	Defrost cycle activation delay from the call	35622	0	38564	192	RW	Word		0...250	min
V4	V4-dE1	Evaporator 1 defrost maximum duration	35618	0	38564	3072	RW	Word		1...250	h/min/s
V4	V4-dE2	Evaporator 2 defrost maximum duration	35619	0	38564	12288	RW	Word		1...250	h/min/s
V4	V4-dS1	Evaporator 1 defrost end temperature	35624	0	38564	49152	RW	Word	Y	-58.0...302.0	°C/°F
V4	V4-dS2	Evaporator 2 defrost end temperature	35625	0	38565	3	RW	Word	Y	-58.0...302.0	°C/°F
V4	V4-dSS	Temperature threshold for starting defrost	35623	0	38565	12	RW	Word	Y	-58.0...302.0	°C/°F
V4	V4-dPO	Defrost activation request at power-on	35626	0	38565	48	RW	Word		0...1	num
V4	V4-tcd	Compressor output activation/deactivation time before a defrost	35627	0	38565	192	RW	Word	Y	-60...60	min
V4	V4-ndE	minimum defrost duration time	35628	0	38565	768	RW	Word		0...250	h/min/s
V4	V4-PdC	Hot gas extraction time at the end of the defrost	35629	0	38565	3072	RW	Word		0...250	min
V4	V4-tPd	Pump down time before defrost start	35631	0	38565	12288	RW	Word		0...255	min
V4	V4-dPH	Regular defrost start hour	35570	0	38565	49152	RW	Word		0...24	h
V4	V4-dPn	Regular defrost start minutes	35571	0	38566	3	RW	Word		0...59	min
V4	V4-dPd	Regular defrost interval duration	35572	0	38566	12	RW	Word		1...7	day
V4	V4-Fd1	1st weekend/holiday day	35519	0	38566	48	RW	Word		0...7	num
V4	V4-Fd2	2nd weekend/holiday day	35520	0	38566	192	RW	Word		0...7	num
V4	V4-Edt	Timeout and defrost end temperature specific to each event	35521	0	38566	768	RW	Word		0...1	num
V4	V4-PrH	Basin heater pre-activation time	35726	0	38595	3072	RW	Word		0...255	min
V4	V4-Fdn	Weekday defrost number	35469	0	38600	3	RW	Word		0...250	num
V4	V4-FFn	Weekend/holiday defrost number	35470	0	38600	12	RW	Word		0...250	num

V4	V4-d1H	Weekday defrost no. 1 start hour	35522	0	38566	3072	RW	Word		0...24	h
V4	V4-d1n	Weekday defrost no. 1 start minute	35523	0	38566	12288	RW	Word		0...59	min
V4	V4-d1t	1st weekday defrost duration	35524	0	38566	49152	RW	Word		0...250	min
V4	V4-d1S	1st weekday defrost end temperature	35525	0	38567	3	RW	Word	Y	-58.0...302.0	°C/°F
V4	V4-d2H	Weekday defrost no. 2 start hour	35526	0	38567	12	RW	Word		V4-d1H...24	h
V4	V4-d2n	Weekday defrost no. 2 start minutes	35527	0	38567	48	RW	Word		0...59	min
V4	V4-d2t	2nd weekday defrost duration	35528	0	38567	192	RW	Word		0...250	min
V4	V4-d2S	2nd weekday defrost end temperature	35529	0	38567	768	RW	Word	Y	-58.0...302.0	°C/°F
V4	V4-d3H	Weekday defrost no. 3 start hour	35530	0	38567	3072	RW	Word		V4-d2H...24	h
V4	V4-d3n	Weekday defrost no. 3 start minutes	35531	0	38567	12288	RW	Word		0...59	min
V4	V4-d3t	3rd weekday defrost duration	35532	0	38567	49152	RW	Word		0...250	min
V4	V4-d3S	3rd weekday defrost end temperature	35533	0	38568	3	RW	Word	Y	-58.0...302.0	°C/°F
V4	V4-d4H	Weekday defrost no. 4 start hour	35534	0	38568	12	RW	Word		V4-d3H...24	h
V4	V4-d4n	Weekday defrost no. 4 start minutes	35535	0	38568	48	RW	Word		0...59	min
V4	V4-d4t	4th weekday defrost duration	35536	0	38568	192	RW	Word		0...250	min
V4	V4-d4S	4th weekday defrost end temperature	35537	0	38568	768	RW	Word	Y	-58.0...302.0	°C/°F
V4	V4-d5H	Weekday defrost no. 5 start hour	35538	0	38568	3072	RW	Word		V4-d4H...24	h
V4	V4-d5n	Weekday defrost no. 5 start minutes	35539	0	38568	12288	RW	Word		0...59	min
V4	V4-d5t	5th weekday defrost duration	35540	0	38568	49152	RW	Word		0...250	min
V4	V4-d5S	5th weekday defrost end temperature	35541	0	38569	3	RW	Word	Y	-58.0...302.0	°C/°F
V4	V4-d6H	Weekday defrost no. 6 start hour	35542	0	38569	12	RW	Word		V4-d5H...24	h
V4	V4-d6n	Weekday defrost no. 6 start minutes	35543	0	38569	48	RW	Word		0...59	min
V4	V4-d6t	6th weekday defrost duration	35544	0	38569	192	RW	Word		0...250	min
V4	V4-d6S	6th weekday defrost end temperature	35545	0	38569	768	RW	Word	Y	-58.0...302.0	°C/°F
V4	V4-F1H	Weekend/holiday defrost no. 1 start hour	35546	0	38569	3072	RW	Word		0...24	h
V4	V4-F1n	Weekend/holiday defrost no. 1 start minute	35547	0	38569	12288	RW	Word		0...59	min
V4	V4-F1t	1st weekend/holiday defrost duration	35548	0	38569	49152	RW	Word		0...250	min
V4	V4-F1S	1st weekend/holiday defrost end temperature	35549	0	38570	3	RW	Word	Y	-58.0...302.0	°C/°F
V4	V4-F2H	Weekend/holiday defrost no. 2 start hour	35550	0	38570	12	RW	Word		V4-F1H...24	h

V4	V4-F2n	Weekend/holiday defrost no. 2 start minutes	35551	0	38570	48	RW	Word		0...59	min
V4	V4-F2t	2nd weekend/holiday defrost duration	35552	0	38570	192	RW	Word		0...250	min
V4	V4-F2S	2nd weekend/holiday defrost end temperature	35553	0	38570	768	RW	Word	Y	-58.0...302.0	°C/°F
V4	V4-F3H	Weekend/holiday defrost no. 3 start hour	35554	0	38570	3072	RW	Word		V4-F2H...24	h
V4	V4-F3n	Weekend/holiday defrost no. 3 start minutes	35555	0	38570	12288	RW	Word		0...59	min
V4	V4-F3t	3rd weekend/holiday defrost duration	35556	0	38570	49152	RW	Word		0...250	min
V4	V4-F3S	3rd weekend/holiday defrost end temperature	35557	0	38571	3	RW	Word	Y	-58.0...302.0	°C/°F
V4	V4-F4H	Weekend/holiday defrost no. 4 start hour	35558	0	38571	12	RW	Word		V4-F3H...24	h
V4	V4-F4n	Weekend/holiday defrost no. 4 start minutes	35559	0	38571	48	RW	Word		0...59	min
V4	V4-F4t	4th weekend/holiday defrost duration	35560	0	38571	192	RW	Word		0...250	min
V4	V4-F4S	4th weekend/holiday defrost end temperature	35561	0	38571	768	RW	Word	Y	-58.0...302.0	°C/°F
V4	V4-F5H	Weekend/holiday defrost no. 5 start hour	35562	0	38571	3072	RW	Word		V4-F4H...24	h
V4	V4-F5n	Weekend/holiday defrost no. 5 start minutes	35563	0	38571	12288	RW	Word		0...59	min
V4	V4-F5t	5th weekend/holiday defrost duration	35564	0	38571	49152	RW	Word		0...250	min
V4	V4-F5S	5th weekend/holiday defrost end temperature	35565	0	38572	3	RW	Word	Y	-58.0...302.0	°C/°F
V4	V4-F6H	Weekend/holiday defrost no. 6 start hour	35566	0	38572	12	RW	Word		V4-F5H...24	h
V4	V4-F6n	Weekend/holiday defrost no. 6 start minutes	35567	0	38572	48	RW	Word		0...59	min
V4	V4-F6t	6th weekend/holiday defrost duration	35568	0	38572	192	RW	Word		0...250	min
V4	V4-F6S	6th weekend/holiday defrost end temperature	35569	0	38572	768	RW	Word	Y	-58.0...302.0	°C/°F
V4	V4-FP1	Selection of evaporator fan probe in normal mode	35632	0	38572	3072	RW	Word		0...7	num
V4	V4-FP2	Selection of evaporator fan probe in defrost	35633	0	38572	12288	RW	Word		0...7	num
V4	V4-FPt	FSt parameter mode (absolute or relative)	35634	0	38572	49152	RW	Word		0...1	num
V4	V4-FSt	Evaporator fan disabling temperature	35635	0	38573	3	RW	Word	Y	-58.0...302.0	°C/°F
V4	V4-FAd	Evaporator fan trigger differential	35636	0	38573	12	RW	Word		.1...25.0	°C/°F

V4	V4-Fdt	Evaporator fan activation delay time after a defrost cycle	35637	0	38573	48	RW	Word		0...250	min
V4	V4-dt	Dripping time	35642	0	38573	192	RW	Word		0...250	min
V4	V4-dFd	Evaporator fan cut-out during defrost	35640	0	38573	768	RW	Word		0...1	num
V4	V4-FCO	Evaporator fan status with compressor output Off	35639	0	38573	3072	RW	Word		0...4	num
V4	V4-Fod	Evaporator fan status with door open	35641	0	38573	12288	RW	Word		0...1	num
V4	V4-FdC	Evaporator fan shutoff delay after compressor deactivation	35638	0	38573	49152	RW	Word		0...250	min
V4	V4-FOn	Evaporator fan On time in cyclical regulator mode	35643	0	38574	3	RW	Word		0...250	min
V4	V4-FOF	Evaporator fan Off time in cyclical regulator mode	35644	0	38574	12	RW	Word		0...250	min
V4	V4-Fnn	Evaporator fan ON time in night mode (duty cycle)	35645	0	38574	48	RW	Word		0...250	min
V4	V4-FnF	Evaporator fan OFF time in night mode (duty cycle)	35646	0	38574	192	RW	Word		0...250	min
V4	V4-FE1	Variable speed fan probe selection	35745	0	38598	48	RW	Word		0...12	num
V4	V4-FEt	Setpoint mode	35746	0	38598	192	RW	Word		0...1	num
V4	V4-FES	Setpoint	35747	0	38598	768	RW	Word	Y	-58...302	num
V4	V4-FEd	Band	35748	0	38598	3072	RW	Word		0.1...50	num
V4	V4-FEu	Cut-off band	35749	0	38598	12288	RW	Word		0...25	num
V4	V4-FEC	Cut-off differential	35750	0	38598	49152	RW	Word		0.1...25	num
V4	V4-FEr	Fan shutoff delay after compressor deactivation	35751	0	38599	3	RW	Word		0...250	min
V4	V4-FE2	Minimum day percentage	35752	0	38599	12	RW	Word		0...100	%
V4	V4-FE3	Maximum day percentage with compressor on	35753	0	38599	48	RW	Word		0...100	%
V4	V4-FE4	Maximum day percentage with compressor off	35754	0	38599	192	RW	Word		0...100	%
V4	V4-FE5	Minimum night percentage	35755	0	38599	768	RW	Word		0...100	%
V4	V4-FE6	Maximum night percentage with compressor on	35756	0	38599	3072	RW	Word		0...100	%
V4	V4-FE7	Maximum night percentage with compressor off	35757	0	38599	12288	RW	Word		0...100	%
V4	V4-FE8	Percentage during defrost	35758	0	38599	49152	RW	Word		0...100	%
V4	V4-FE9	Percentage in the event of probe error	35759	0	38611	12	RW	Word		0...100	%
V4	V4-FEA	Maximum pick-up speed	35760	0	38611	48	RW	Word		0...100	%
V4	V4-FEb	Fan pick-up time	35761	0	38611	192	RW	Word		0...250	s
V4	V4-FEP	Fan forcing period at pick-up speed	35762	0	38611	768	RW	Word		0...250	min

V4	V4-rA1	Temperature alarm probe 1 selection	35660	0	38574	768	RW	Word		0...7	num
V4	V4-rA2	Temperature alarm probe 2 selection	35661	0	38574	3072	RW	Word		0...7	num
V4	V4-Att	Alarm mode (absolute or relative)	35662	0	38574	12288	RW	Word		0...1	num
V4	V4-AFd	Alarm activation differential	35663	0	38574	49152	RW	Word		.1...25.0	°C/°F
V4	V4-HA1	Maximum alarm 1 threshold	35664	0	38575	3	RW	Word	Y	V4-LA1...302.0	°C/°F
V4	V4-LA1	Minimum alarm 1 threshold	35665	0	38575	12	RW	Word	Y	-58.0...V4-HA1	°C/°F
V4	V4-HA2	Maximum alarm 2 threshold	35666	0	38575	48	RW	Word	Y	V4-LA2...302.0	°C/°F
V4	V4-LA2	Minimum alarm 2 threshold	35667	0	38575	192	RW	Word	Y	-58.0...V4-HA2	°C/°F
V4	V4-PAO	Temperature alarm exclusion time from power-on	35668	0	38575	768	RW	Word		0...10	h
V4	V4-dAO	Exclusion time for temperature alarms after a defrost cycle	35670	0	38575	3072	RW	Word		0...250	min
V4	V4-OAO	High and low temperature alarms exclusion time after closing the door	35669	0	38575	12288	RW	Word		0...10	h
V4	V4-tdO	Door open alarm exclusion time	35714	0	38575	49152	RW	Word		0...250	num
V4	V4-tA1	Probe 1 High/Minimum Alarm Delay	35671	0	38576	3	RW	Word		0...250	min
V4	V4-tA2	Probe 2 High/Minimum Alarm Delay	35672	0	38576	12	RW	Word		0...250	min
V4	V4-dAt	Defrost ended due to timeout alarm signaling	35630	0	38576	48	RW	Word		0...1	num
V4	V4-EAL	Regulators inhibited by external alarm	35674	0	38576	192	RW	Word		0...2	num
V4	V4-rA3	Leak detection probe selection	35733	0	38596	12288	RW	Word		0...8	num
V4	V4-ALL	Low threshold leak alarm	35734	0	38596	49152	RW	Word		0...V4-ALH	num
V4	V4-ALH	High threshold leak alarm	35735	0	38597	3	RW	Word		V4-ALL...100	num
V4	V4-dAL	Alarm leak differential	35736	0	38597	12	RW	Word		0.1...100	num
V4	V4-AL1	Time probe remains above the low threshold due to leak alarm activation	35737	0	38597	48	RW	Word		0...250	min
V4	V4-AL2	Time probe remains above the high threshold due to leak alarm activation	35744	0	38598	12	RW	Word		0...250	min
V4	V4-tP	Enables alarm acknowledgment with any key	35715	0	38576	768	RW	Word		0...1	num
V4	V4-Art	Regular watchdog alarm activation period	35659	0	38576	3072	RW	Word		0...250	min*10
V4	V4-dSd	Enable light relay from door switch	35656	0	38576	12288	RW	Word		0...1	num
V4	V4-dLt	Light relay off delay from door closure	35657	0	38576	49152	RW	Word		0...250	min

V4	V4-OFL	Enable cold room lights off via key during the delay set in parameter dLt	35658	0	38577	3	RW	Word		0...1	num
V4	V4-dOd	Enable utility shutoff upon door switch activation	35673	0	38577	12	RW	Word		0...3	num
V4	V4-dOA	Behavior forced by digital input	35675	0	38577	48	RW	Word		0...5	num
V4	V4-PEA	Enable forced behavior from door switch and/or external alarm.	35676	0	38577	192	RW	Word		0...3	num
V4	V4-dCO	Compressor activation delay from acknowledgment	35677	0	38577	768	RW	Word		0...250	min
V4	V4-dFO	Fan enabling delay from acknowledgment	35678	0	38577	3072	RW	Word		0...250	min
V4	V4-ASb	Instrument off active light/auxiliary digital input or key	35704	0	38577	12288	RW	Word		0...1	num
V4	V4-L00	Shared probe	35456	0	38577	49152	RW	Word		0...7	num
V4	V4-L01	Distributed viewing (refers to slave)	35457	0	38578	3	RW	Word		0...2	num
V4	V4-L02	Setpoint synchronization	35458	0	38578	12	RW	Word		0...1	num
V4	V4-L03	Defrost synchronization	35459	0	38578	48	RW	Word		0...2	num
V4	V4-L04	Inhibit resources at the end of defrost	35460	0	38578	192	RW	Word		0...1	num
V4	V4-L05	Stand-by synchronization	35461	0	38578	768	RW	Word		0...1	num
V4	V4-L06	Lights synchronization	35462	0	38578	3072	RW	Word		0...1	num
V4	V4-L07	Reduced set synchronization	35463	0	38578	12288	RW	Word		0...1	num
V4	V4-L08	AUX synchronization	35464	0	38578	49152	RW	Word		0...1	num
V4	V4-L09	Shared saturation probe	35465	0	38579	3	RW	Word		0...1	num
V4	V4-L10	Resource unlocking timeout during synchronized defrosts	35716	0	38579	12	RW	Word		0...250	min
V4	V4-L11	Number of devices connected in Link2	35466	0	38596	48	RW	Word		0...8	num
V4	V4-L12	Alarm relay sharing in Link2	35467	0	38596	192	RW	Word		0...2	num
V4	V4-L13	Link2 serial frame configuration	35727	0	38595	12288	RW	Word		0...2	num
V4	V4-L14	Force cool mode	35743	0	38598	3	RW	Word		0...1	num
V4	V4-dcS	Deep cooling setpoint	35650	0	38579	768	RW	Word	Y	-58.0...302.0	°C/°F
V4	V4-tdc	Deep cooling duration	35651	0	38579	3072	RW	Word		0...250	min
V4	V4-dcc	Defrost delay after deep cooling	35652	0	38579	12288	RW	Word		0...250	min
V4	V4-ESt	Type of action for the Energy Saving function	35579	0	38579	49152	RW	Word		0...8	num
V4	V4-ESF	Night mode activation (Energy Saving)	35647	0	38580	3	RW	Word		0...1	num
V4	V4-Cdt	Door closing time	35648	0	38580	12	RW	Word		0...255	min*10
V4	V4-ESo	Low consumption mode disabling timeout (door switch)	35649	0	38580	48	RW	Word		0...10	num

V4	V4-OS1	Offset on setpoint 1	35596	0	38580	192	RW	Word	Y	-50.0...50.0	°C/°F
V4	V4-OS2	Offset on setpoint 2	35597	0	38580	768	RW	Word	Y	-50.0...50.0	°C/°F
V4	V4-Od1	Refrigerated cabinets energy saving offset 1	35598	0	38580	3072	RW	Word	Y	-50.0...50.0	°C/°F
V4	V4-Od2	Refrigerated cabinets energy saving offset 2	35599	0	38580	12288	RW	Word	Y	-50.0...50.0	°C/°F
V4	V4-dn1	Differential during energy saving mode 1	35587	0	38580	49152	RW	Word	Y	-58.0...302.0	°C/°F
V4	V4-dn2	Differential during energy saving mode 2	35588	0	38581	3	RW	Word	Y	-58.0...302.0	°C/°F
V4	V4-EdH	Weekday energy saving start hour	35573	0	38581	12	RW	Word		0...24	h
V4	V4-Edn	Weekday energy saving start minutes	35574	0	38581	48	RW	Word		0...59	min
V4	V4-Edd	Weekday energy saving duration	35575	0	38581	192	RW	Word		1...72	h
V4	V4-EFH	Weekend/holiday energy saving start hour	35576	0	38581	768	RW	Word		0...24	h
V4	V4-EFn	Weekend/holiday energy saving start minutes	35577	0	38581	3072	RW	Word		0...59	min
V4	V4-EFd	Weekend/holiday energy saving duration	35578	0	38581	12288	RW	Word		1...72	h
V4	V4-FH	Frame heater probe selection	35679	0	38581	49152	RW	Word		0...9	num
V4	V4-FHt	Frame heater period	35681	0	38582	3	RW	Word		1...2500	s
V4	V4-FH0	Frame heater set	35682	0	38582	12	RW	Word	Y	-58.0...302.0	°C/°F
V4	V4-FH1	Frame heater offset	35683	0	38582	48	RW	Word		0...25.0	°C/°F
V4	V4-FH2	Frame heater band	35684	0	38582	192	RW	Word	Y	-58.0...302.0	°C/°F
V4	V4-FH3	Frame heater minimum percentage/duty-cycle	35685	0	38582	768	RW	Word		0...100	%
V4	V4-FH4	Frame heater maximum percentage/day duty-cycle	35686	0	38582	3072	RW	Word		0...100	%
V4	V4-FH5	Frame heater maximum percentage/night duty-cycle	35687	0	38582	12288	RW	Word		0...100	%
V4	V4-FH6	Frame heater percentage/duty-cycle in defrost	35688	0	38582	49152	RW	Word		0...100	%
V4	V4-LOC	Disable terminal	35691	0	38583	3	RW	Word		0...1	num
V4	V4-PS1	Password 1 value	35692	0	38583	12	RW	Word		0...250	num
V4	V4-PS2	Password 2 value	35693	0	38583	48	RW	Word		0...250	num
V4	V4-ndt	Display with decimal point	35694	0	38583	192	RW	Word		0...1	num
V4	V4-CA1	Analog input 1 calibration	35500	0	38583	768	RW	Word	Y	-30.0...30.0	°C/°F
V4	V4-CA2	Analog input 2 calibration	35501	0	38583	3072	RW	Word	Y	-30.0...30.0	°C/°F
V4	V4-CA3	Analog input 3 calibration	35502	0	38583	12288	RW	Word	Y	-30.0...30.0	°C/°F
V4	V4-CA4	Analog input 4 calibration	35503	0	38583	49152	RW	Word	Y	-30.0...30.0	°C/°F
V4	V4-CA5	Analog input 5 calibration	35504	0	38584	3	RW	Word	Y	-30.0...30.0	°C/°F

V4	V4-CA6	Analog input 6 calibration	35505	0	38584	12	RW	Word	Y	-30...30	bar/psi
V4	V4-CA7	Analog input 7 calibration	35506	0	38584	48	RW	Word	Y	-30...30	bar/psi
V4	V4-LdL	Minimum display value	35695	0	38584	192	RW	Word	Y	-58.0...V4-HdL	°C/°F
V4	V4-HdL	Maximum display value	35696	0	38584	768	RW	Word	Y	V4-LdL...302.0	°C/°F
V4	V4-ddL	Display lock mode during a defrost	35697	0	38584	3072	RW	Word		0...2	num
V4	V4-Ldd	Display lock timeout from end of defrost	35698	0	38584	12288	RW	Word		0...250	min
V4	V4-dro	Select °C / °F	35699	0	38584	49152	RW	Word		0...1	num
V4	V4-SbP	Pressure unit of measure	35700	0	38585	3	RW	Word		0...1	num
V4	V4-ddd	Select main display value	35701	0	38585	12	RW	Word		0...8	num
V4	V4-ddE	Resource displayed on ECHO	35702	0	38585	48	RW	Word		0...9	num
V4	V4-rPH	Receiver maximum valve opening %	35653	0	38585	192	RW	Word		0...5	num
V4	V4-H00	Select analog input type NTC/PTC	35468	0	38585	768	RW	Word		0...2	num
V4	V4-H02	Function activation time from terminal	35703	0	38585	3072	RW	Word		0...250	s
V4	V4-H08	Stand-by operating mode	35705	0	38585	12288	RW	Word		0...2	num
V4	V4-H11	Digital input 1 configurability and polarity	35471	0	38585	49152	RW	Word	Y	-18...18	num
V4	V4-H12	Digital input 2 configurability and polarity	35472	0	38586	3	RW	Word	Y	-18...18	num
V4	V4-H13	Digital input 3 configurability and polarity	35473	0	38586	12	RW	Word	Y	-18...18	num
V4	V4-H14	Digital input 4 configurability and polarity	35474	0	38586	48	RW	Word	Y	-18...18	num
V4	V4-H15	Digital input 5 configurability and polarity	35475	0	38586	192	RW	Word	Y	-18...18	num
V4	V4-H16	Digital input 6 configurability and polarity	35476	0	38586	768	RW	Word	Y	-18...18	num
V4	V4-H17	Digital input 7 configurability and polarity	35477	0	38586	3072	RW	Word	Y	-18...18	num
V4	V4-H18	Digital input 8 configurability and polarity	35478	0	38586	12288	RW	Word	Y	-18...18	num
V4	V4-i01	Digital input 9 configurability and polarity	35738	0	38597	192	RW	Word	Y	-18...18	num
V4	V4-i02	Digital input 10 configurability and polarity	35739	0	38597	768	RW	Word	Y	-18...18	num
V4	V4-dti	Digital inputs 1 and 2 delay unit of measure	35487	0	38586	49152	RW	Word		0...1	num
V4	V4-d11	D.I. 1 activation indication delay time	35479	0	38587	3	RW	Word		0...255	min/s
V4	V4-d12	D.I. 2 activation indication delay time	35480	0	38587	12	RW	Word		0...255	min/s

V4	V4-d13	D.I. 3 activation indication delay time	35481	0	38587	48	RW	Word		0...255	min
V4	V4-d14	D.I. 4 activation indication delay time	35482	0	38587	192	RW	Word		0...255	min
V4	V4-d15	D.I. 5 activation indication delay time	35483	0	38587	768	RW	Word		0...255	min
V4	V4-d16	D.I. 6 activation indication delay time	35484	0	38587	3072	RW	Word		0...255	min
V4	V4-d17	D.I. 7 activation indication delay time	35485	0	38587	12288	RW	Word		0...255	min
V4	V4-d18	D.I. 8 activation indication delay time	35486	0	38587	49152	RW	Word		0...255	min
V4	V4-01i	D.I. 9 activation indication delay time	35740	0	38597	3072	RW	Word		0...255	min/s
V4	V4-02i	D.I. 10 activation indication delay time	35741	0	38597	12288	RW	Word		0...255	min
V4	V4-H21	Configurability of digital output 1	35508	0	38588	3	RW	Word		0...19	num
V4	V4-H22	Configurability of digital output 2	35509	0	38588	12	RW	Word		0...19	num
V4	V4-H23	Configurability of digital output 3	35510	0	38588	48	RW	Word		0...19	num
V4	V4-H24	Configurability of digital output 4	35511	0	38588	192	RW	Word		0...19	num
V4	V4-H25	Configurability of digital output 5	35512	0	38588	768	RW	Word		0...19	num
V4	V4-H27	Configurability of digital output 7	35514	0	38588	12288	RW	Word		0...19	num
V4	V4-H29	Enable buzzer	35515	0	38588	49152	RW	Word		0...1	num
V4	V4-d01	Configurability of digital output 8	35731	0	38596	768	RW	Word		0...19	num
V4	V4-d02	Configurability of digital output 9	35732	0	38596	3072	RW	Word		0...19	num
V4	V4-H31	Configurability of the UP key	35706	0	38589	3	RW	Word		0...9	num
V4	V4-H32	Configurability of the DOWN key	35707	0	38589	12	RW	Word		0...9	num
V4	V4-H33	Configurability of the ESC key	35708	0	38589	48	RW	Word		0...9	num
V4	V4-H34	Configurability of the Free 1 key	35709	0	38589	192	RW	Word		0...9	num
V4	V4-H35	Configurability of the Free 2 key	35710	0	38589	768	RW	Word		0...9	num
V4	V4-H36	Configurability of the Free 3 key	35711	0	38589	3072	RW	Word		0...9	num
V4	V4-H37	Configurability of the Free 4 key	35712	0	38589	12288	RW	Word		0...9	num
V4	V4-H41	Analog input 1 calibration	35488	0	38589	49152	RW	Word		0...2	num
V4	V4-H42	Analog input 2 calibration	35489	0	38590	3	RW	Word		0...2	num
V4	V4-H43	Analog input 3 calibration	35490	0	38590	12	RW	Word		0...2	num
V4	V4-H44	Analog input 4 calibration	35491	0	38590	48	RW	Word		0...2	num
V4	V4-H45	Analog input 5 calibration	35492	0	38590	192	RW	Word		0...2	num
V4	V4-H46	Analog input 6 calibration	35493	0	38590	768	RW	Word		0...2	num
V4	V4-H47	Analog input 7 calibration	35494	0	38590	3072	RW	Word		0...2	num

V4	V4-H48	Analog input 8 calibration	35742	0	38597	49152	RW	Word		0...2	num
V4	V4-H50	Configurability of analog output 1	35516	0	38590	12288	RW	Word		0...1	num
V4	V4-H51	Function associated with analog output	35517	0	38590	49152	RW	Word		0...3	num
V4	V4-H68	RTC present	35518	0	38591	3	RW	Word		0...1	num
V4	V4-H70	Selection of 1st sensor for virtual probe	35496	0	38591	12	RW	Word		0...5	num
V4	V4-H71	Selection of 2nd sensor for virtual probe	35497	0	38591	48	RW	Word		0...5	num
V4	V4-H72	Day virtual probe calculation %	35498	0	38591	192	RW	Word		0...100	%
V4	V4-H73	Night virtual probe calculation %	35499	0	38591	768	RW	Word		0...100	%
V4	V4-H74	Selection of 1st sensor for filtered virtual probe	35727	0	38595	49152	RW	Word		0...65635	num
V4	V4-H75	Percentage in thousandths of the incoming signal for filtered virtual probe	35728	0	38596	3	RW	Word		0...6563.5	num
V4	V4-H76	Filtered virtual probe offset	35730	0	38596	12	RW	Word		0...6563.5	num
V4	V4-EtY	Selection of electronic expansion valve driver	35713	0	38591	3072	RW	Word		0...2	num
V4	V4-OHP	Selection of oil temperature probe	35720	0	38594	12288	RW	Word		0...8	num
V4	V4-OSP	Oil heater setpoint	35721	0	38594	49152	RW	Word	Y	V4-OLS...V4-OHS	°C/°F
V4	V4-OHd	Oil heater differential	35722	0	38595	3	RW	Word		.1...25.0	°C/°F
V4	V4-OHS	Maximum oil heater setpoint value that can be set	35724	0	38595	48	RW	Word	Y	V4-OLS...302.0	°C/°F
V4	V4-OLS	Minimum oil heater setpoint value that can be set	35725	0	38595	192	RW	Word	Y	-58.0...V4-OHS	°C/°F
V4	UL	Visibility of parameter transfer function (Device -> UNICARD/MFK)	-	-	38594	3	RW	Word		0...3	num
V4	dL	Visibility of parameter transfer function (UNICARD/MFK -> Device)	-	-	38594	12	RW	Word		0...3	num
V4	Fr	Visibility of UNICARD/MFK formatting function	-	-	38594	48	RW	Word		0...3	num

Application 5 parameters

V5	V5-rE	Regulation type	35964	0	38656	3	RW	Word		0...6	num
V5	V5-rP1	Thermostat regulation probe 1	35965	0	38656	12	RW	Word		0...8	num
V5	V5-rP2	Thermostat regulation probe 2	35966	0	38656	48	RW	Word		0...9	num
V5	V5-SP1	Regulation setpoint 1	35967	0	38656	192	RW	Word	Y	V5-LS1...V5-HS1	°C/°F
V5	V5-dF1	Setpoint differential 1	35968	0	38656	768	RW	Word	Y	-58.0...302.0	°C/°F
V5	V5-SP2	Regulation setpoint 2	35969	0	38656	3072	RW	Word	Y	V5-LS2...V5-HS2	°C/°F
V5	V5-dF2	Setpoint differential 2	35970	0	38656	12288	RW	Word	Y	-58.0...302.0	°C/°F
V5	V5-Stt	Differential management mode	35973	0	38656	49152	RW	Word		0...1	num

V5	V5-HS1	Maximum value that can be set for Setpoint 1	35976	0	38657	3	RW	Word	Y	V5-LS1...V5-HdL	°C/°F
V5	V5-LS1	Minimum value that can be set for Setpoint 1	35977	0	38657	12	RW	Word	Y	V5-LdL...V5-HS1	°C/°F
V5	V5-HS2	Maximum value that can be set for Setpoint 2	35978	0	38657	48	RW	Word	Y	V5-LS2...V5-HdL	°C/°F
V5	V5-LS2	Minimum value that can be set for Setpoint 2	35979	0	38657	192	RW	Word	Y	V5-LdL...V5-HS2	°C/°F
V5	V5-HC1	Setpoint 1 operating mode (Heating/Cooling)	35974	0	38657	768	RW	Word		0...1	num
V5	V5-HC2	Setpoint 2 operating mode (Heating/Cooling)	35975	0	38657	3072	RW	Word		0...1	num
V5	V5-Cit	Minimum compressor output activation time	35984	0	38657	49152	RW	Word		0...250	min
V5	V5-CAt	Maximum compressor output activation time	35985	0	38658	3	RW	Word		0...250	min
V5	V5-Ont	Compressor output ON time if regulation probe is faulty	35990	0	38658	12	RW	Word		0...250	min
V5	V5-OFt	Compressor output OFF time if regulation probe is faulty	35991	0	38658	48	RW	Word		0...250	min
V5	V5-dOn	Compressor output activation delay from call	35986	0	38658	192	RW	Word		0...250	s
V5	V5-dOF	Compressor output activation delay from switch-off	35987	0	38658	768	RW	Word		0...250	min
V5	V5-dbi	Delay between two consecutive compressor output power-ons	35988	0	38658	3072	RW	Word		0...250	min
V5	V5-OdO	Output activation delay at startup	35989	0	38658	12288	RW	Word		0...250	min
V5	V5-CFP	Condenser pre-ventilation time in Heat/Cool	36073	0	38659	12	RW	Word		0...255	s
V5	V5-CFd	Condenser fan cut-out during defrosting.	36074	0	38659	48	RW	Word		0...1	num
V5	V5-OF1	Remote offset	35995	0	38659	192	RW	Word	Y	-50.0...50.0	°C/°F
V5	V5-Pot	Pump down time	36101	0	38690	192	RW	Word		0...250	s
V5	V5-SS1	Compressor softstart: advance hotgas valve opening	36102	0	38690	768	RW	Word		0...250	s
V5	V5-SS2	Compressor softstart: delay hotgas valve closing	36103	0	38690	3072	RW	Word		0...250	s
V5	V5-dP1	Select defrost probe 1	35996	0	38659	768	RW	Word		0...8	num
V5	V5-dP2	Defrost probe 2 selection	35997	0	38659	3072	RW	Word		0...8	num
V5	V5-dtY	Type of defrost	36000	0	38659	12288	RW	Word		0...4	num
V5	V5-dFt	Dual evaporator defrost activation mode	35998	0	38659	49152	RW	Word		0...2	num
V5	V5-dit	Interval between defrosts	36001	0	38660	3	RW	Word		0...250	h/min/s

V5	V5-dt1	Unit of measure for defrost intervals	36004	0	38660	12	RW	Word		0...2	num
V5	V5-dt2	Unit of measure for defrost duration	36005	0	38660	48	RW	Word		0...2	num
V5	V5-dCt	Defrost interval count mode	35999	0	38660	192	RW	Word		0...5	num
V5	V5-dOH	Defrost cycle activation delay from the call	36006	0	38660	768	RW	Word		0...250	min
V5	V5-dE1	Evaporator 1 defrost maximum duration	36002	0	38660	3072	RW	Word		1...250	h/min/s
V5	V5-dE2	Evaporator 2 defrost maximum duration	36003	0	38660	12288	RW	Word		1...250	h/min/s
V5	V5-dS1	Evaporator 1 defrost end temperature	36008	0	38660	49152	RW	Word	Y	-58.0...302.0	°C/°F
V5	V5-dS2	Evaporator 2 defrost end temperature	36009	0	38661	3	RW	Word	Y	-58.0...302.0	°C/°F
V5	V5-dSS	Temperature threshold for starting defrost	36007	0	38661	12	RW	Word	Y	-58.0...302.0	°C/°F
V5	V5-dPO	Defrost activation request at power-on	36010	0	38661	48	RW	Word		0...1	num
V5	V5-tcd	Compressor output activation/deactivation time before a defrost	36011	0	38661	192	RW	Word	Y	-60...60	min
V5	V5-ndE	minimum defrost duration time	36012	0	38661	768	RW	Word		0...250	h/min/s
V5	V5-PdC	Hot gas extraction time at the end of the defrost	36013	0	38661	3072	RW	Word		0...250	min
V5	V5-tPd	Pump down time before defrost start	36015	0	38661	12288	RW	Word		0...255	min
V5	V5-dPH	Regular defrost start hour	35954	0	38661	49152	RW	Word		0...24	h
V5	V5-dPn	Regular defrost start minutes	35955	0	38662	3	RW	Word		0...59	min
V5	V5-dPd	Regular defrost interval duration	35956	0	38662	12	RW	Word		1...7	day
V5	V5-Fd1	1st weekend/holiday day	35903	0	38662	48	RW	Word		0...7	num
V5	V5-Fd2	2nd weekend/holiday day	35904	0	38662	192	RW	Word		0...7	num
V5	V5-Edt	Timeout and defrost end temperature specific to each event	35905	0	38662	768	RW	Word		0...1	num
V5	V5-PrH	Basin heater pre-activation time	36110	0	38691	3072	RW	Word		0...255	min
V5	V5-Fdn	Weekday defrost number	35853	0	38696	3	RW	Word		0...250	num
V5	V5-FFn	Weekend/holiday defrost number	35854	0	38696	12	RW	Word		0...250	num
V5	V5-d1H	Weekday defrost no. 1 start hour	35906	0	38662	3072	RW	Word		0...24	h
V5	V5-d1n	Weekday defrost no. 1 start minute	35907	0	38662	12288	RW	Word		0...59	min
V5	V5-d1t	1st weekday defrost duration	35908	0	38662	49152	RW	Word		0...250	min
V5	V5-d1S	1st weekday defrost end temperature	35909	0	38663	3	RW	Word	Y	-58.0...302.0	°C/°F
V5	V5-d2H	Weekday defrost no. 2 start hour	35910	0	38663	12	RW	Word		V5-d1H...24	h
V5	V5-d2n	Weekday defrost no. 2 start minutes	35911	0	38663	48	RW	Word		0...59	min

V5	V5-d2t	2nd weekday defrost duration	35912	0	38663	192	RW	Word		0...250	min
V5	V5-d2S	2nd weekday defrost end temperature	35913	0	38663	768	RW	Word	Y	-58.0...302.0	°C/°F
V5	V5-d3H	Weekday defrost no. 3 start hour	35914	0	38663	3072	RW	Word		V5-d2H...24	h
V5	V5-d3n	Weekday defrost no. 3 start minutes	35915	0	38663	12288	RW	Word		0...59	min
V5	V5-d3t	3rd weekday defrost duration	35916	0	38663	49152	RW	Word		0...250	min
V5	V5-d3S	3rd weekday defrost end temperature	35917	0	38664	3	RW	Word	Y	-58.0...302.0	°C/°F
V5	V5-d4H	Weekday defrost no. 4 start hour	35918	0	38664	12	RW	Word		V5-d3H...24	h
V5	V5-d4n	Weekday defrost no. 4 start minutes	35919	0	38664	48	RW	Word		0...59	min
V5	V5-d4t	4th weekday defrost duration	35920	0	38664	192	RW	Word		0...250	min
V5	V5-d4S	4th weekday defrost end temperature	35921	0	38664	768	RW	Word	Y	-58.0...302.0	°C/°F
V5	V5-d5H	Weekday defrost no. 5 start hour	35922	0	38664	3072	RW	Word		V5-d4H...24	h
V5	V5-d5n	Weekday defrost no. 5 start minutes	35923	0	38664	12288	RW	Word		0...59	min
V5	V5-d5t	5th weekday defrost duration	35924	0	38664	49152	RW	Word		0...250	min
V5	V5-d5S	5th weekday defrost end temperature	35925	0	38665	3	RW	Word	Y	-58.0...302.0	°C/°F
V5	V5-d6H	Weekday defrost no. 6 start hour	35926	0	38665	12	RW	Word		V5-d5H...24	h
V5	V5-d6n	Weekday defrost no. 6 start minutes	35927	0	38665	48	RW	Word		0...59	min
V5	V5-d6t	6th weekday defrost duration	35928	0	38665	192	RW	Word		0...250	min
V5	V5-d6S	6th weekday defrost end temperature	35929	0	38665	768	RW	Word	Y	-58.0...302.0	°C/°F
V5	V5-F1H	Weekend/holiday defrost no. 1 start hour	35930	0	38665	3072	RW	Word		0...24	h
V5	V5-F1n	Weekend/holiday defrost no. 1 start minute	35931	0	38665	12288	RW	Word		0...59	min
V5	V5-F1t	1st weekend/holiday defrost duration	35932	0	38665	49152	RW	Word		0...250	min
V5	V5-F1S	1st weekend/holiday defrost end temperature	35933	0	38666	3	RW	Word	Y	-58.0...302.0	°C/°F
V5	V5-F2H	Weekend/holiday defrost no. 2 start hour	35934	0	38666	12	RW	Word		V5-F1H...24	h
V5	V5-F2n	Weekend/holiday defrost no. 2 start minutes	35935	0	38666	48	RW	Word		0...59	min
V5	V5-F2t	2nd weekend/holiday defrost duration	35936	0	38666	192	RW	Word		0...250	min
V5	V5-F2S	2nd weekend/holiday defrost end temperature	35937	0	38666	768	RW	Word	Y	-58.0...302.0	°C/°F
V5	V5-F3H	Weekend/holiday defrost no. 3 start hour	35938	0	38666	3072	RW	Word		V5-F2H...24	h

V5	V5-F3n	Weekend/holiday defrost no. 3 start minutes	35939	0	38666	12288	RW	Word		0...59	min
V5	V5-F3t	3rd weekend/holiday defrost duration	35940	0	38666	49152	RW	Word		0...250	min
V5	V5-F3S	3rd weekend/holiday defrost end temperature	35941	0	38667	3	RW	Word	Y	-58.0...302.0	°C/°F
V5	V5-F4H	Weekend/holiday defrost no. 4 start hour	35942	0	38667	12	RW	Word		V5-F3H...24	h
V5	V5-F4n	Weekend/holiday defrost no. 4 start minutes	35943	0	38667	48	RW	Word		0...59	min
V5	V5-F4t	4th weekend/holiday defrost duration	35944	0	38667	192	RW	Word		0...250	min
V5	V5-F4S	4th weekend/holiday defrost end temperature	35945	0	38667	768	RW	Word	Y	-58.0...302.0	°C/°F
V5	V5-F5H	Weekend/holiday defrost no. 5 start hour	35946	0	38667	3072	RW	Word		V5-F4H...24	h
V5	V5-F5n	Weekend/holiday defrost no. 5 start minutes	35947	0	38667	12288	RW	Word		0...59	min
V5	V5-F5t	5th weekend/holiday defrost duration	35948	0	38667	49152	RW	Word		0...250	min
V5	V5-F5S	5th weekend/holiday defrost end temperature	35949	0	38668	3	RW	Word	Y	-58.0...302.0	°C/°F
V5	V5-F6H	Weekend/holiday defrost no. 6 start hour	35950	0	38668	12	RW	Word		V5-F5H...24	h
V5	V5-F6n	Weekend/holiday defrost no. 6 start minutes	35951	0	38668	48	RW	Word		0...59	min
V5	V5-F6t	6th weekend/holiday defrost duration	35952	0	38668	192	RW	Word		0...250	min
V5	V5-F6S	6th weekend/holiday defrost end temperature	35953	0	38668	768	RW	Word	Y	-58.0...302.0	°C/°F
V5	V5-FP1	Selection of evaporator fan probe in normal mode	36016	0	38668	3072	RW	Word		0...7	num
V5	V5-FP2	Selection of evaporator fan probe in defrost	36017	0	38668	12288	RW	Word		0...7	num
V5	V5-FPt	FSt parameter mode (absolute or relative)	36018	0	38668	49152	RW	Word		0...1	num
V5	V5-FSt	Evaporator fan disabling temperature	36019	0	38669	3	RW	Word	Y	-58.0...302.0	°C/°F
V5	V5-FAd	Evaporator fan trigger differential	36020	0	38669	12	RW	Word		.1...25.0	°C/°F
V5	V5-Fdt	Evaporator fan activation delay time after a defrost cycle	36021	0	38669	48	RW	Word		0...250	min
V5	V5-dt	Dripping time	36026	0	38669	192	RW	Word		0...250	min
V5	V5-dFd	Evaporator fan cut-out during defrost	36024	0	38669	768	RW	Word		0...1	num
V5	V5-FCO	Evaporator fan status with compressor output Off	36023	0	38669	3072	RW	Word		0...4	num
V5	V5-Fod	Evaporator fan status with door open	36025	0	38669	12288	RW	Word		0...1	num

V5	V5-FdC	Evaporator fan shutoff delay after compressor deactivation	36022	0	38669	49152	RW	Word		0...250	min
V5	V5-FOn	Evaporator fan On time in cyclical regulator mode	36027	0	38670	3	RW	Word		0...250	min
V5	V5-FOF	Evaporator fan Off time in cyclical regulator mode	36028	0	38670	12	RW	Word		0...250	min
V5	V5-Fnn	Evaporator fan ON time in night mode (duty cycle)	36029	0	38670	48	RW	Word		0...250	min
V5	V5-FnF	Evaporator fan OFF time in night mode (duty cycle)	36030	0	38670	192	RW	Word		0...250	min
V5	V5-FE1	Variable speed fan probe selection	36129	0	38694	48	RW	Word		0...12	num
V5	V5-FEt	Setpoint mode	36130	0	38694	192	RW	Word		0...1	num
V5	V5-FES	Setpoint	36131	0	38694	768	RW	Word	Y	-58...302	num
V5	V5-FEd	Band	36132	0	38694	3072	RW	Word		0.1...50	num
V5	V5-FEu	Cut-off band	36133	0	38694	12288	RW	Word		0...25	num
V5	V5-FEC	Cut-off differential	36134	0	38694	49152	RW	Word		0.1...25	num
V5	V5-FEr	Fan shutoff delay after compressor deactivation	36135	0	38695	3	RW	Word		0...250	min
V5	V5-FE2	Minimum day percentage	36136	0	38695	12	RW	Word		0...100	%
V5	V5-FE3	Maximum day percentage with compressor on	36137	0	38695	48	RW	Word		0...100	%
V5	V5-FE4	Maximum day percentage with compressor off	36138	0	38695	192	RW	Word		0...100	%
V5	V5-FE5	Minimum night percentage	36139	0	38695	768	RW	Word		0...100	%
V5	V5-FE6	Maximum night percentage with compressor on	36140	0	38695	3072	RW	Word		0...100	%
V5	V5-FE7	Maximum night percentage with compressor off	36141	0	38695	12288	RW	Word		0...100	%
V5	V5-FE8	Percentage during defrost	36142	0	38695	49152	RW	Word		0...100	%
V5	V5-FE9	Percentage in the event of probe error	36143	0	38707	12	RW	Word		0...100	%
V5	V5-FEA	Maximum pick-up speed	36144	0	38707	48	RW	Word		0...100	%
V5	V5-FEb	Fan pick-up time	36145	0	38707	192	RW	Word		0...250	s
V5	V5-FEP	Fan forcing period at pick-up speed	36146	0	38707	768	RW	Word		0...250	min
V5	V5-rA1	Temperature alarm probe 1 selection	36044	0	38670	768	RW	Word		0...7	num
V5	V5-rA2	Temperature alarm probe 2 selection	36045	0	38670	3072	RW	Word		0...7	num
V5	V5-Att	Alarm mode (absolute or relative)	36046	0	38670	12288	RW	Word		0...1	num
V5	V5-AFd	Alarm activation differential	36047	0	38670	49152	RW	Word		.1...25.0	°C/°F
V5	V5-HA1	Maximum alarm 1 threshold	36048	0	38671	3	RW	Word	Y	V5-LA1...302.0	°C/°F
V5	V5-LA1	Minimum alarm 1 threshold	36049	0	38671	12	RW	Word	Y	-58.0...V5-HA1	°C/°F

V5	V5-HA2	Maximum alarm 2 threshold	36050	0	38671	48	RW	Word	Y	V5-LA2...302.0	°C/°F
V5	V5-LA2	Minimum alarm 2 threshold	36051	0	38671	192	RW	Word	Y	-58.0...V5-HA2	°C/°F
V5	V5-PAO	Temperature alarm exclusion time from power-on	36052	0	38671	768	RW	Word		0...10	h
V5	V5-dAO	Exclusion time for temperature alarms after a defrost cycle	36054	0	38671	3072	RW	Word		0...250	min
V5	V5-OAO	High and low temperature alarms exclusion time after closing the door	36053	0	38671	12288	RW	Word		0...10	h
V5	V5-tdO	Door open alarm exclusion time	36098	0	38671	49152	RW	Word		0...250	num
V5	V5-tA1	Probe 1 High/Minimum Alarm Delay	36055	0	38672	3	RW	Word		0...250	min
V5	V5-tA2	Probe 2 High/Minimum Alarm Delay	36056	0	38672	12	RW	Word		0...250	min
V5	V5-dAt	Defrost ended due to timeout alarm signaling	36014	0	38672	48	RW	Word		0...1	num
V5	V5-EAL	Regulators inhibited by external alarm	36058	0	38672	192	RW	Word		0...2	num
V5	V5-rA3	Leak detection probe selection	36117	0	38692	12288	RW	Word		0...8	num
V5	V5-ALL	Low threshold leak alarm	36118	0	38692	49152	RW	Word		0...V5-ALH	num
V5	V5-ALH	High threshold leak alarm	36119	0	38693	3	RW	Word		V5-ALL...100	num
V5	V5-dAL	Alarm leak differential	36120	0	38693	12	RW	Word		0.1...100	num
V5	V5-AL1	Time probe remains above the low threshold due to leak alarm activation	36121	0	38693	48	RW	Word		0...250	min
V5	V5-AL2	Time probe remains above the high threshold due to leak alarm activation	36128	0	38694	12	RW	Word		0...250	min
V5	V5-tP	Enables alarm acknowledgment with any key	36099	0	38672	768	RW	Word		0...1	num
V5	V5-Art	Regular watchdog alarm activation period	36043	0	38672	3072	RW	Word		0...250	min*10
V5	V5-dSd	Enable light relay from door switch	36040	0	38672	12288	RW	Word		0...1	num
V5	V5-dLt	Light relay off delay from door closure	36041	0	38672	49152	RW	Word		0...250	min
V5	V5-OFL	Enable cold room lights off via key during the delay set in parameter dLt	36042	0	38673	3	RW	Word		0...1	num
V5	V5-dOd	Enable utility shutoff upon door switch activation	36057	0	38673	12	RW	Word		0...3	num
V5	V5-dOA	Behavior forced by digital input	36059	0	38673	48	RW	Word		0...5	num
V5	V5-PEA	Enable forced behavior from door switch and/or external alarm.	36060	0	38673	192	RW	Word		0...3	num

V5	V5-dCO	Compressor activation delay from acknowledgment	36061	0	38673	768	RW	Word		0...250	min
V5	V5-dFO	Fan enabling delay from acknowledgment	36062	0	38673	3072	RW	Word		0...250	min
V5	V5-ASb	Instrument off active light/auxiliary digital input or key	36088	0	38673	12288	RW	Word		0...1	num
V5	V5-L00	Shared probe	35840	0	38673	49152	RW	Word		0...7	num
V5	V5-L01	Distributed viewing (refers to slave)	35841	0	38674	3	RW	Word		0...2	num
V5	V5-L02	Setpoint synchronization	35842	0	38674	12	RW	Word		0...1	num
V5	V5-L03	Defrost synchronization	35843	0	38674	48	RW	Word		0...2	num
V5	V5-L04	Inhibit resources at the end of defrost	35844	0	38674	192	RW	Word		0...1	num
V5	V5-L05	Stand-by synchronization	35845	0	38674	768	RW	Word		0...1	num
V5	V5-L06	Lights synchronization	35846	0	38674	3072	RW	Word		0...1	num
V5	V5-L07	Reduced set synchronization	35847	0	38674	12288	RW	Word		0...1	num
V5	V5-L08	AUX synchronization	35848	0	38674	49152	RW	Word		0...1	num
V5	V5-L09	Shared saturation probe	35849	0	38675	3	RW	Word		0...1	num
V5	V5-L10	Resource unlocking timeout during synchronized defrosts	36100	0	38675	12	RW	Word		0...250	min
V5	V5-L11	Number of devices connected in Link2	35850	0	38692	48	RW	Word		0...8	num
V5	V5-L12	Alarm relay sharing in Link2	35851	0	38692	192	RW	Word		0...2	num
V5	V5-L13	Link2 serial frame configuration	36111	0	38691	12288	RW	Word		0...2	num
V5	V5-L14	Force cool mode	36127	0	38694	3	RW	Word		0...1	num
V5	V5-dcS	Deep cooling setpoint	36034	0	38675	768	RW	Word	Y	-58.0...302.0	°C/°F
V5	V5-tdc	Deep cooling duration	36035	0	38675	3072	RW	Word		0...250	min
V5	V5-dcc	Defrost delay after deep cooling	36036	0	38675	12288	RW	Word		0...250	min
V5	V5-ESst	Type of action for the Energy Saving function	35963	0	38675	49152	RW	Word		0...8	num
V5	V5-ESF	Night mode activation (Energy Saving)	36031	0	38676	3	RW	Word		0...1	num
V5	V5-Cdt	Door closing time	36032	0	38676	12	RW	Word		0...255	min*10
V5	V5-ESo	Low consumption mode disabling timeout (door switch)	36033	0	38676	48	RW	Word		0...10	num
V5	V5-OS1	Offset on setpoint 1	35980	0	38676	192	RW	Word	Y	-50.0...50.0	°C/°F
V5	V5-OS2	Offset on setpoint 2	35981	0	38676	768	RW	Word	Y	-50.0...50.0	°C/°F
V5	V5-Od1	Refrigerated cabinets energy saving offset 1	35982	0	38676	3072	RW	Word	Y	-50.0...50.0	°C/°F
V5	V5-Od2	Refrigerated cabinets energy saving offset 2	35983	0	38676	12288	RW	Word	Y	-50.0...50.0	°C/°F
V5	V5-dn1	Differential during energy saving mode 1	35971	0	38676	49152	RW	Word	Y	-58.0...302.0	°C/°F
V5	V5-dn2	Differential during energy saving mode 2	35972	0	38677	3	RW	Word	Y	-58.0...302.0	°C/°F
V5	V5-EdH	Weekday energy saving start hour	35957	0	38677	12	RW	Word		0...24	h

V5	V5-Edn	Weekday energy saving start minutes	35958	0	38677	48	RW	Word		0...59	min
V5	V5-Edd	Weekday energy saving duration	35959	0	38677	192	RW	Word		1...72	h
V5	V5-EFH	Weekend/holiday energy saving start hour	35960	0	38677	768	RW	Word		0...24	h
V5	V5-EFn	Weekend/holiday energy saving start minutes	35961	0	38677	3072	RW	Word		0...59	min
V5	V5-EFd	Weekend/holiday energy saving duration	35962	0	38677	12288	RW	Word		1...72	h
V5	V5-FH	Frame heater probe selection	36063	0	38677	49152	RW	Word		0...9	num
V5	V5-FHt	Frame heater period	36065	0	38678	3	RW	Word		1...2500	s
V5	V5-FH0	Frame heater set	36066	0	38678	12	RW	Word	Y	-58.0...302.0	°C/°F
V5	V5-FH1	Frame heater offset	36067	0	38678	48	RW	Word		0...25.0	°C/°F
V5	V5-FH2	Frame heater band	36068	0	38678	192	RW	Word	Y	-58.0...302.0	°C/°F
V5	V5-FH3	Frame heater minimum percentage/duty-cycle	36069	0	38678	768	RW	Word		0...100	%
V5	V5-FH4	Frame heater maximum percentage/day duty-cycle	36070	0	38678	3072	RW	Word		0...100	%
V5	V5-FH5	Frame heater maximum percentage/night duty-cycle	36071	0	38678	12288	RW	Word		0...100	%
V5	V5-FH6	Frame heater percentage/duty-cycle in defrost	36072	0	38678	49152	RW	Word		0...100	%
V5	V5-LOC	Disable terminal	36075	0	38679	3	RW	Word		0...1	num
V5	V5-PS1	Password 1 value	36076	0	38679	12	RW	Word		0...250	num
V5	V5-PS2	Password 2 value	36077	0	38679	48	RW	Word		0...250	num
V5	V5-ndt	Display with decimal point	36078	0	38679	192	RW	Word		0...1	num
V5	V5-CA1	Analog input 1 calibration	35884	0	38679	768	RW	Word	Y	-30.0...30.0	°C/°F
V5	V5-CA2	Analog input 2 calibration	35885	0	38679	3072	RW	Word	Y	-30.0...30.0	°C/°F
V5	V5-CA3	Analog input 3 calibration	35886	0	38679	12288	RW	Word	Y	-30.0...30.0	°C/°F
V5	V5-CA4	Analog input 4 calibration	35887	0	38679	49152	RW	Word	Y	-30.0...30.0	°C/°F
V5	V5-CA5	Analog input 5 calibration	35888	0	38680	3	RW	Word	Y	-30.0...30.0	°C/°F
V5	V5-CA6	Analog input 6 calibration	35889	0	38680	12	RW	Word	Y	-30...30	bar/psi
V5	V5-CA7	Analog input 7 calibration	35890	0	38680	48	RW	Word	Y	-30...30	bar/psi
V5	V5-LdL	Minimum display value	36079	0	38680	192	RW	Word	Y	-58.0...V5-HdL	°C/°F
V5	V5-HdL	Maximum display value	36080	0	38680	768	RW	Word	Y	V5-LdL...302.0	°C/°F
V5	V5-ddL	Display lock mode during a defrost	36081	0	38680	3072	RW	Word		0...2	num
V5	V5-Ldd	Display lock timeout from end of defrost	36082	0	38680	12288	RW	Word		0...250	min
V5	V5-dro	Select °C / °F	36083	0	38680	49152	RW	Word		0...1	num

V5	V5-SbP	Pressure unit of measure	36084	0	38681	3	RW	Word		0...1	num
V5	V5-ddd	Select main display value	36085	0	38681	12	RW	Word		0...8	num
V5	V5-ddE	Resource displayed on ECHO	36086	0	38681	48	RW	Word		0...9	num
V5	V5-rPH	Receiver maximum valve opening %	36037	0	38681	192	RW	Word		0...5	num
V5	V5-H00	Select analog input type NTC/PTC	35852	0	38681	768	RW	Word		0...2	num
V5	V5-H02	Function activation time from terminal	36087	0	38681	3072	RW	Word		0...250	s
V5	V5-H08	Stand-by operating mode	36089	0	38681	12288	RW	Word		0...2	num
V5	V5-H11	Digital input 1 configurability and polarity	35855	0	38681	49152	RW	Word	Y	-18...18	num
V5	V5-H12	Digital input 2 configurability and polarity	35856	0	38682	3	RW	Word	Y	-18...18	num
V5	V5-H13	Digital input 3 configurability and polarity	35857	0	38682	12	RW	Word	Y	-18...18	num
V5	V5-H14	Digital input 4 configurability and polarity	35858	0	38682	48	RW	Word	Y	-18...18	num
V5	V5-H15	Digital input 5 configurability and polarity	35859	0	38682	192	RW	Word	Y	-18...18	num
V5	V5-H16	Digital input 6 configurability and polarity	35860	0	38682	768	RW	Word	Y	-18...18	num
V5	V5-H17	Digital input 7 configurability and polarity	35861	0	38682	3072	RW	Word	Y	-18...18	num
V5	V5-H18	Digital input 8 configurability and polarity	35862	0	38682	12288	RW	Word	Y	-18...18	num
V5	V5-i01	Digital input 9 configurability and polarity	36122	0	38693	192	RW	Word	Y	-18...18	num
V5	V5-i02	Digital input 10 configurability and polarity	36123	0	38693	768	RW	Word	Y	-18...18	num
V5	V5-dti	Digital inputs 1 and 2 delay unit of measure	35871	0	38682	49152	RW	Word		0...1	num
V5	V5-d11	D.I. 1 activation indication delay time	35863	0	38683	3	RW	Word		0...255	min/s
V5	V5-d12	D.I. 2 activation indication delay time	35864	0	38683	12	RW	Word		0...255	min/s
V5	V5-d13	D.I. 3 activation indication delay time	35865	0	38683	48	RW	Word		0...255	min
V5	V5-d14	D.I. 4 activation indication delay time	35866	0	38683	192	RW	Word		0...255	min
V5	V5-d15	D.I. 5 activation indication delay time	35867	0	38683	768	RW	Word		0...255	min
V5	V5-d16	D.I. 6 activation indication delay time	35868	0	38683	3072	RW	Word		0...255	min
V5	V5-d17	D.I. 7 activation indication delay time	35869	0	38683	12288	RW	Word		0...255	min
V5	V5-d18	D.I. 8 activation indication delay time	35870	0	38683	49152	RW	Word		0...255	min

V5	V5-01i	D.I. 9 activation indication delay time	36124	0	38693	3072	RW	Word		0...255	min/s
V5	V5-02i	D.I. 10 activation indication delay time	36125	0	38693	12288	RW	Word		0...255	min
V5	V5-H21	Configurability of digital output 1	35892	0	38684	3	RW	Word		0...19	num
V5	V5-H22	Configurability of digital output 2	35893	0	38684	12	RW	Word		0...19	num
V5	V5-H23	Configurability of digital output 3	35894	0	38684	48	RW	Word		0...19	num
V5	V5-H24	Configurability of digital output 4	35895	0	38684	192	RW	Word		0...19	num
V5	V5-H25	Configurability of digital output 5	35896	0	38684	768	RW	Word		0...19	num
V5	V5-H27	Configurability of digital output 7	35898	0	38684	12288	RW	Word		0...19	num
V5	V5-H29	Enable buzzer	35899	0	38684	49152	RW	Word		0...1	num
V5	V5-d01	Configurability of digital output 8	36115	0	38692	768	RW	Word		0...19	num
V5	V5-d02	Configurability of digital output 9	36116	0	38692	3072	RW	Word		0...19	num
V5	V5-H31	Configurability of the UP key	36090	0	38685	3	RW	Word		0...9	num
V5	V5-H32	Configurability of the DOWN key	36091	0	38685	12	RW	Word		0...9	num
V5	V5-H33	Configurability of the ESC key	36092	0	38685	48	RW	Word		0...9	num
V5	V5-H34	Configurability of the Free 1 key	36093	0	38685	192	RW	Word		0...9	num
V5	V5-H35	Configurability of the Free 2 key	36094	0	38685	768	RW	Word		0...9	num
V5	V5-H36	Configurability of the Free 3 key	36095	0	38685	3072	RW	Word		0...9	num
V5	V5-H37	Configurability of the Free 4 key	36096	0	38685	12288	RW	Word		0...9	num
V5	V5-H41	Analog input 1 calibration	35872	0	38685	49152	RW	Word		0...2	num
V5	V5-H42	Analog input 2 calibration	35873	0	38686	3	RW	Word		0...2	num
V5	V5-H43	Analog input 3 calibration	35874	0	38686	12	RW	Word		0...2	num
V5	V5-H44	Analog input 4 calibration	35875	0	38686	48	RW	Word		0...2	num
V5	V5-H45	Analog input 5 calibration	35876	0	38686	192	RW	Word		0...2	num
V5	V5-H46	Analog input 6 calibration	35877	0	38686	768	RW	Word		0...2	num
V5	V5-H47	Analog input 7 calibration	35878	0	38686	3072	RW	Word		0...2	num
V5	V5-H48	Analog input 8 calibration	36126	0	38693	49152	RW	Word		0...2	num
V5	V5-H50	Configurability of analog output 1	35900	0	38686	12288	RW	Word		0...1	num
V5	V5-H51	Function associated with analog output	35901	0	38686	49152	RW	Word		0...3	num
V5	V5-H68	RTC present	35902	0	38687	3	RW	Word		0...1	num
V5	V5-H70	Selection of 1st sensor for virtual probe	35880	0	38687	12	RW	Word		0...5	num
V5	V5-H71	Selection of 2nd sensor for virtual probe	35881	0	38687	48	RW	Word		0...5	num

V5	V5-H72	Day virtual probe calculation %	35882	0	38687	192	RW	Word		0...100	%
V5	V5-H73	Night virtual probe calculation %	35883	0	38687	768	RW	Word		0...100	%
V5	V5-H74	Selection of 1st sensor for filtered virtual probe	36112	0	38691	49152	RW	Word		0...65635	num
V5	V5-H75	Percentage in thousandths of the incoming signal for filtered virtual probe	36113	0	38692	3	RW	Word		0...65635	num
V5	V5-H76	Filtered virtual probe offset	36114	0	38692	12	RW	Word		0...65635	num
V5	V5-EtY	Selection of electronic expansion valve driver	36097	0	38687	3072	RW	Word		0...2	num
V5	V5-OHP	Selection of oil temperature probe	36104	0	38690	12288	RW	Word		0...8	num
V5	V5-OSP	Oil heater setpoint	36105	0	38690	49152	RW	Word	Y	V5-OLS...V5-OHS	°C/°F
V5	V5-OHd	Oil heater differential	36106	0	38691	3	RW	Word		.1...25.0	°C/°F
V5	V5-OHS	Maximum oil heater setpoint value that can be set	36108	0	38691	48	RW	Word	Y	V5-OLS...302.0	°C/°F
V5	V5-OLS	Minimum oil heater setpoint value that can be set	36109	0	38691	192	RW	Word	Y	-58.0...V5-OHS	°C/°F
V5	UL	Visibility of parameter transfer function (Device -> UNICARD/MFK)	-	-	38690	3	RW	Word		0...3	num
V5	dL	Visibility of parameter transfer function (UNICARD/MFK -> Device)	-	-	38690	12	RW	Word		0...3	num
V5	Fr	Visibility of UNICARD/MFK formatting function	-	-	38690	48	RW	Word		0...3	num

Application 6 parameters

V6	V6-rE	Regulation type	36348	0	38752	3	RW	Word		0...6	num
V6	V6-rP1	Thermostat regulation probe 1	36349	0	38752	12	RW	Word		0...8	num
V6	V6-rP2	Thermostat regulation probe 2	36350	0	38752	48	RW	Word		0...9	num
V6	V6-SP1	Regulation setpoint 1	36351	0	38752	192	RW	Word	Y	V6-LS1...V6-HS1	°C/°F
V6	V6-dF1	Setpoint differential 1	36352	0	38752	768	RW	Word	Y	-58.0...302.0	°C/°F
V6	V6-SP2	Regulation setpoint 2	36353	0	38752	3072	RW	Word	Y	V6-LS2...V6-HS2	°C/°F
V6	V6-dF2	Setpoint differential 2	36354	0	38752	12288	RW	Word	Y	-58.0...302.0	°C/°F
V6	V6-Stt	Differential management mode	36357	0	38752	49152	RW	Word		0...1	num
V6	V6-HS1	Maximum value that can be set for Setpoint 1	36360	0	38753	3	RW	Word	Y	V6-LS1...V6-HdL	°C/°F
V6	V6-LS1	Minimum value that can be set for Setpoint 1	36361	0	38753	12	RW	Word	Y	V6-LdL...V6-HS1	°C/°F
V6	V6-HS2	Maximum value that can be set for Setpoint 2	36362	0	38753	48	RW	Word	Y	V6-LS2...V6-HdL	°C/°F
V6	V6-LS2	Minimum value that can be set for Setpoint 2	36363	0	38753	192	RW	Word	Y	V6-LdL...V6-HS2	°C/°F

V6	V6-HC1	Setpoint 1 operating mode (Heating/Cooling)	36358	0	38753	768	RW	Word		0...1	num
V6	V6-HC2	Setpoint 2 operating mode (Heating/Cooling)	36359	0	38753	3072	RW	Word		0...1	num
V6	V6-Cit	Minimum compressor output activation time	36368	0	38753	49152	RW	Word		0...250	min
V6	V6-CAt	Maximum compressor output activation time	36369	0	38754	3	RW	Word		0...250	min
V6	V6-Ont	Compressor output ON time if regulation probe is faulty	36374	0	38754	12	RW	Word		0...250	min
V6	V6-OFt	Compressor output OFF time if regulation probe is faulty	36375	0	38754	48	RW	Word		0...250	min
V6	V6-dOn	Compressor output activation delay from call	36370	0	38754	192	RW	Word		0...250	s
V6	V6-dOF	Compressor output activation delay from switch-off	36371	0	38754	768	RW	Word		0...250	min
V6	V6-dbi	Delay between two consecutive compressor output power-ons	36372	0	38754	3072	RW	Word		0...250	min
V6	V6-OdO	Output activation delay at startup	36373	0	38754	12288	RW	Word		0...250	min
V6	V6-CFP	Condenser pre-ventilation time in Heat/Cool	36457	0	38755	12	RW	Word		0...255	s
V6	V6-CFd	Condenser fan cut-out during defrosting.	36458	0	38755	48	RW	Word		0...1	num
V6	V6-OF1	Remote offset	36379	0	38755	192	RW	Word	Y	-50.0...50.0	°C/°F
V6	V6-Pot	Pump down time	36485	0	38786	192	RW	Word		0...250	s
V6	V6-SS1	Compressor softstart: advance hotgas valve opening	36486	0	38786	768	RW	Word		0...250	s
V6	V6-SS2	Compressor softstart: delay hotgas valve closing	36487	0	38786	3072	RW	Word		0...250	s
V6	V6-dP1	Select defrost probe 1	36380	0	38755	768	RW	Word		0...8	num
V6	V6-dP2	Defrost probe 2 selection	36381	0	38755	3072	RW	Word		0...8	num
V6	V6-dtY	Type of defrost	36384	0	38755	12288	RW	Word		0...4	num
V6	V6-dFt	Dual evaporator defrost activation mode	36382	0	38755	49152	RW	Word		0...2	num
V6	V6-dit	Interval between defrosts	36385	0	38756	3	RW	Word		0...250	h/min/s
V6	V6-dt1	Unit of measure for defrost intervals	36388	0	38756	12	RW	Word		0...2	num
V6	V6-dt2	Unit of measure for defrost duration	36389	0	38756	48	RW	Word		0...2	num
V6	V6-dCt	Defrost interval count mode	36383	0	38756	192	RW	Word		0...5	num
V6	V6-dOH	Defrost cycle activation delay from the call	36390	0	38756	768	RW	Word		0...250	min
V6	V6-dE1	Evaporator 1 defrost maximum duration	36386	0	38756	3072	RW	Word		1...250	h/min/s

V6	V6-dE2	Evaporator 2 defrost maximum duration	36387	0	38756	12288	RW	Word		1...250	h/min/s
V6	V6-dS1	Evaporator 1 defrost end temperature	36392	0	38756	49152	RW	Word	Y	-58.0...302.0	°C/°F
V6	V6-dS2	Evaporator 2 defrost end temperature	36393	0	38757	3	RW	Word	Y	-58.0...302.0	°C/°F
V6	V6-dSS	Temperature threshold for starting defrost	36391	0	38757	12	RW	Word	Y	-58.0...302.0	°C/°F
V6	V6-dPO	Defrost activation request at power-on	36394	0	38757	48	RW	Word		0...1	num
V6	V6-tcd	Compressor output activation/deactivation time before a defrost	36395	0	38757	192	RW	Word	Y	-60...60	min
V6	V6-ndE	minimum defrost duration time	36396	0	38757	768	RW	Word		0...250	h/min/s
V6	V6-PdC	Hot gas extraction time at the end of the defrost	36397	0	38757	3072	RW	Word		0...250	min
V6	V6-tPd	Pump down time before defrost start	36399	0	38757	12288	RW	Word		0...255	min
V6	V6-dPH	Regular defrost start hour	36338	0	38757	49152	RW	Word		0...24	h
V6	V6-dPn	Regular defrost start minutes	36339	0	38758	3	RW	Word		0...59	min
V6	V6-dPd	Regular defrost interval duration	36340	0	38758	12	RW	Word		1...7	day
V6	V6-Fd1	1st weekend/holiday day	36287	0	38758	48	RW	Word		0...7	num
V6	V6-Fd2	2nd weekend/holiday day	36288	0	38758	192	RW	Word		0...7	num
V6	V6-Edt	Timeout and defrost end temperature specific to each event	36289	0	38758	768	RW	Word		0...1	num
V6	V6-PrH	Basin heater pre-activation time	36494	0	38787	3072	RW	Word		0...255	min
V6	V6-Fdn	Weekday defrost number	36237	0	38792	3	RW	Word		0...250	num
V6	V6-FFn	Weekend/holiday defrost number	36238	0	38792	12	RW	Word		0...250	num
V6	V6-d1H	Weekday defrost no. 1 start hour	36290	0	38758	3072	RW	Word		0...24	h
V6	V6-d1n	Weekday defrost no. 1 start minute	36291	0	38758	12288	RW	Word		0...59	min
V6	V6-d1t	1st weekday defrost duration	36292	0	38758	49152	RW	Word		0...250	min
V6	V6-d1S	1st weekday defrost end temperature	36293	0	38759	3	RW	Word	Y	-58.0...302.0	°C/°F
V6	V6-d2H	Weekday defrost no. 2 start hour	36294	0	38759	12	RW	Word		V6-d1H...24	h
V6	V6-d2n	Weekday defrost no. 2 start minutes	36295	0	38759	48	RW	Word		0...59	min
V6	V6-d2t	2nd weekday defrost duration	36296	0	38759	192	RW	Word		0...250	min
V6	V6-d2S	2nd weekday defrost end temperature	36297	0	38759	768	RW	Word	Y	-58.0...302.0	°C/°F
V6	V6-d3H	Weekday defrost no. 3 start hour	36298	0	38759	3072	RW	Word		V6-d2H...24	h
V6	V6-d3n	Weekday defrost no. 3 start minutes	36299	0	38759	12288	RW	Word		0...59	min
V6	V6-d3t	3rd weekday defrost duration	36300	0	38759	49152	RW	Word		0...250	min

V6	V6-d3S	3rd weekday defrost end temperature	36301	0	38760	3	RW	Word	Y	-58.0...302.0	°C/°F
V6	V6-d4H	Weekday defrost no. 4 start hour	36302	0	38760	12	RW	Word		V6-d3H...24	h
V6	V6-d4n	Weekday defrost no. 4 start minutes	36303	0	38760	48	RW	Word		0...59	min
V6	V6-d4t	4th weekday defrost duration	36304	0	38760	192	RW	Word		0...250	min
V6	V6-d4S	4th weekday defrost end temperature	36305	0	38760	768	RW	Word	Y	-58.0...302.0	°C/°F
V6	V6-d5H	Weekday defrost no. 5 start hour	36306	0	38760	3072	RW	Word		V6-d4H...24	h
V6	V6-d5n	Weekday defrost no. 5 start minutes	36307	0	38760	12288	RW	Word		0...59	min
V6	V6-d5t	5th weekday defrost duration	36308	0	38760	49152	RW	Word		0...250	min
V6	V6-d5S	5th weekday defrost end temperature	36309	0	38761	3	RW	Word	Y	-58.0...302.0	°C/°F
V6	V6-d6H	Weekday defrost no. 6 start hour	36310	0	38761	12	RW	Word		V6-d5H...24	h
V6	V6-d6n	Weekday defrost no. 6 start minutes	36311	0	38761	48	RW	Word		0...59	min
V6	V6-d6t	6th weekday defrost duration	36312	0	38761	192	RW	Word		0...250	min
V6	V6-d6S	6th weekday defrost end temperature	36313	0	38761	768	RW	Word	Y	-58.0...302.0	°C/°F
V6	V6-F1H	Weekend/holiday defrost no. 1 start hour	36314	0	38761	3072	RW	Word		0...24	h
V6	V6-F1n	Weekend/holiday defrost no. 1 start minute	36315	0	38761	12288	RW	Word		0...59	min
V6	V6-F1t	1st weekend/holiday defrost duration	36316	0	38761	49152	RW	Word		0...250	min
V6	V6-F1S	1st weekend/holiday defrost end temperature	36317	0	38762	3	RW	Word	Y	-58.0...302.0	°C/°F
V6	V6-F2H	Weekend/holiday defrost no. 2 start hour	36318	0	38762	12	RW	Word		V6-F1H...24	h
V6	V6-F2n	Weekend/holiday defrost no. 2 start minutes	36319	0	38762	48	RW	Word		0...59	min
V6	V6-F2t	2nd weekend/holiday defrost duration	36320	0	38762	192	RW	Word		0...250	min
V6	V6-F2S	2nd weekend/holiday defrost end temperature	36321	0	38762	768	RW	Word	Y	-58.0...302.0	°C/°F
V6	V6-F3H	Weekend/holiday defrost no. 3 start hour	36322	0	38762	3072	RW	Word		V6-F2H...24	h
V6	V6-F3n	Weekend/holiday defrost no. 3 start minutes	36323	0	38762	12288	RW	Word		0...59	min
V6	V6-F3t	3rd weekend/holiday defrost duration	36324	0	38762	49152	RW	Word		0...250	min
V6	V6-F3S	3rd weekend/holiday defrost end temperature	36325	0	38763	3	RW	Word	Y	-58.0...302.0	°C/°F
V6	V6-F4H	Weekend/holiday defrost no. 4 start hour	36326	0	38763	12	RW	Word		V6-F3H...24	h

V6	V6-F4n	Weekend/holiday defrost no. 4 start minutes	36327	0	38763	48	RW	Word		0...59	min
V6	V6-F4t	4th weekend/holiday defrost duration	36328	0	38763	192	RW	Word		0...250	min
V6	V6-F4S	4th weekend/holiday defrost end temperature	36329	0	38763	768	RW	Word	Y	-58.0...302.0	°C/°F
V6	V6-F5H	Weekend/holiday defrost no. 5 start hour	36330	0	38763	3072	RW	Word		V6-F4H...24	h
V6	V6-F5n	Weekend/holiday defrost no. 5 start minutes	36331	0	38763	12288	RW	Word		0...59	min
V6	V6-F5t	5th weekend/holiday defrost duration	36332	0	38763	49152	RW	Word		0...250	min
V6	V6-F5S	5th weekend/holiday defrost end temperature	36333	0	38764	3	RW	Word	Y	-58.0...302.0	°C/°F
V6	V6-F6H	Weekend/holiday defrost no. 6 start hour	36334	0	38764	12	RW	Word		V6-F5H...24	h
V6	V6-F6n	Weekend/holiday defrost no. 6 start minutes	36335	0	38764	48	RW	Word		0...59	min
V6	V6-F6t	6th weekend/holiday defrost duration	36336	0	38764	192	RW	Word		0...250	min
V6	V6-F6S	6th weekend/holiday defrost end temperature	36337	0	38764	768	RW	Word	Y	-58.0...302.0	°C/°F
V6	V6-FP1	Selection of evaporator fan probe in normal mode	36400	0	38764	3072	RW	Word		0...7	num
V6	V6-FP2	Selection of evaporator fan probe in defrost	36401	0	38764	12288	RW	Word		0...7	num
V6	V6-FPt	FSt parameter mode (absolute or relative)	36402	0	38764	49152	RW	Word		0...1	num
V6	V6-FSt	Evaporator fan disabling temperature	36403	0	38765	3	RW	Word	Y	-58.0...302.0	°C/°F
V6	V6-FAd	Evaporator fan trigger differential	36404	0	38765	12	RW	Word		.1...25.0	°C/°F
V6	V6-Fdt	Evaporator fan activation delay time after a defrost cycle	36405	0	38765	48	RW	Word		0...250	min
V6	V6-dt	Dripping time	36410	0	38765	192	RW	Word		0...250	min
V6	V6-dFd	Evaporator fan cut-out during defrost	36408	0	38765	768	RW	Word		0...1	num
V6	V6-FCO	Evaporator fan status with compressor output Off	36407	0	38765	3072	RW	Word		0...4	num
V6	V6-Fod	Evaporator fan status with door open	36409	0	38765	12288	RW	Word		0...1	num
V6	V6-FdC	Evaporator fan shutoff delay after compressor deactivation	36406	0	38765	49152	RW	Word		0...250	min
V6	V6-FOn	Evaporator fan On time in cyclical regulator mode	36411	0	38766	3	RW	Word		0...250	min
V6	V6-FOF	Evaporator fan Off time in cyclical regulator mode	36412	0	38766	12	RW	Word		0...250	min

V6	V6-Fnn	Evaporator fan ON time in night mode (duty cycle)	36413	0	38766	48	RW	Word		0...250	min
V6	V6-FnF	Evaporator fan OFF time in night mode (duty cycle)	36414	0	38766	192	RW	Word		0...250	min
V6	V6-FE1	Variable speed fan probe selection	36513	0	38790	48	RW	Word		0...12	num
V6	V6-FEt	Setpoint mode	36514	0	38790	192	RW	Word		0...1	num
V6	V6-FES	Setpoint	36515	0	38790	768	RW	Word	Y	-58...302	num
V6	V6-FEd	Band	36516	0	38790	3072	RW	Word		0.1...50	num
V6	V6-FEu	Cut-off band	36517	0	38790	12288	RW	Word		0...25	num
V6	V6-FEC	Cut-off differential	36518	0	38790	49152	RW	Word		0.1...25	num
V6	V6-FEr	Fan shutoff delay after compressor deactivation	36519	0	38791	3	RW	Word		0...250	min
V6	V6-FE2	Minimum day percentage	36520	0	38791	12	RW	Word		0...100	%
V6	V6-FE3	Maximum day percentage with compressor on	36521	0	38791	48	RW	Word		0...100	%
V6	V6-FE4	Maximum day percentage with compressor off	36522	0	38791	192	RW	Word		0...100	%
V6	V6-FE5	Minimum night percentage	36523	0	38791	768	RW	Word		0...100	%
V6	V6-FE6	Maximum night percentage with compressor on	36524	0	38791	3072	RW	Word		0...100	%
V6	V6-FE7	Maximum night percentage with compressor off	36525	0	38791	12288	RW	Word		0...100	%
V6	V6-FE8	Percentage during defrost	36526	0	38791	49152	RW	Word		0...100	%
V6	V6-FE9	Percentage in the event of probe error	36527	0	38803	12	RW	Word		0...100	%
V6	V6-FEA	Maximum pick-up speed	36528	0	38803	48	RW	Word		0...100	%
V6	V6-FEb	Fan pick-up time	36529	0	38803	192	RW	Word		0...250	s
V6	V6-FEP	Fan forcing period at pick-up speed	36530	0	38803	768	RW	Word		0...250	min
V6	V6-rA1	Temperature alarm probe 1 selection	36428	0	38766	768	RW	Word		0...7	num
V6	V6-rA2	Temperature alarm probe 2 selection	36429	0	38766	3072	RW	Word		0...7	num
V6	V6-Att	Alarm mode (absolute or relative)	36430	0	38766	12288	RW	Word		0...1	num
V6	V6-AFd	Alarm activation differential	36431	0	38766	49152	RW	Word		.1...25.0	°C/°F
V6	V6-HA1	Maximum alarm 1 threshold	36432	0	38767	3	RW	Word	Y	V6-LA1...302.0	°C/°F
V6	V6-LA1	Minimum alarm 1 threshold	36433	0	38767	12	RW	Word	Y	-58.0...V6-HA1	°C/°F
V6	V6-HA2	Maximum alarm 2 threshold	36434	0	38767	48	RW	Word	Y	V6-LA2...302.0	°C/°F
V6	V6-LA2	Minimum alarm 2 threshold	36435	0	38767	192	RW	Word	Y	-58.0...V6-HA2	°C/°F
V6	V6-PAO	Temperature alarm exclusion time from power-on	36436	0	38767	768	RW	Word		0...10	h

V6	V6-dAO	Exclusion time for temperature alarms after a defrost cycle	36438	0	38767	3072	RW	Word		0...250	min
V6	V6-OAO	High and low temperature alarms exclusion time after closing the door	36437	0	38767	12288	RW	Word		0...10	h
V6	V6-tdO	Door open alarm exclusion time	36482	0	38767	49152	RW	Word		0...250	num
V6	V6-tA1	Probe 1 High/Minimum Alarm Delay	36439	0	38768	3	RW	Word		0...250	min
V6	V6-tA2	Probe 2 High/Minimum Alarm Delay	36440	0	38768	12	RW	Word		0...250	min
V6	V6-dAt	Defrost ended due to timeout alarm signaling	36398	0	38768	48	RW	Word		0...1	num
V6	V6-EAL	Regulators inhibited by external alarm	36442	0	38768	192	RW	Word		0...2	num
V6	V6-rA3	Leak detection probe selection	36501	0	38788	12288	RW	Word		0...8	num
V6	V6-ALL	Low threshold leak alarm	36502	0	38788	49152	RW	Word		0...V6-ALH	num
V6	V6-ALH	High threshold leak alarm	36503	0	38789	3	RW	Word		V6-ALL...100	num
V6	V6-dAL	Alarm leak differential	36504	0	38789	12	RW	Word		0.1...100	num
V6	V6-AL1	Time probe remains above the low threshold due to leak alarm activation	36505	0	38789	48	RW	Word		0...250	min
V6	V6-AL2	Time probe remains above the high threshold due to leak alarm activation	36512	0	38790	12	RW	Word		0...250	min
V6	V6-tP	Enables alarm acknowledgment with any key	36483	0	38768	768	RW	Word		0...1	num
V6	V6-Art	Regular watchdog alarm activation period	36427	0	38768	3072	RW	Word		0...250	min*10
V6	V6-dSd	Enable light relay from door switch	36424	0	38768	12288	RW	Word		0...1	num
V6	V6-dLt	Light relay off delay from door closure	36425	0	38768	49152	RW	Word		0...250	min
V6	V6-OFL	Enable cold room lights off via key during the delay set in parameter dLt	36426	0	38769	3	RW	Word		0...1	num
V6	V6-dOd	Enable utility shutoff upon door switch activation	36441	0	38769	12	RW	Word		0...3	num
V6	V6-dOA	Behavior forced by digital input	36443	0	38769	48	RW	Word		0...5	num
V6	V6-PEA	Enable forced behavior from door switch and/or external alarm.	36444	0	38769	192	RW	Word		0...3	num
V6	V6-dCO	Compressor activation delay from acknowledgment	36445	0	38769	768	RW	Word		0...250	min
V6	V6-dFO	Fan enabling delay from acknowledgment	36446	0	38769	3072	RW	Word		0...250	min

V6	V6-ASb	Instrument off active light/auxiliary digital input or key	36472	0	38769	12288	RW	Word		0...1	num
V6	V6-L00	Shared probe	36224	0	38769	49152	RW	Word		0...7	num
V6	V6-L01	Distributed viewing (refers to slave)	36225	0	38770	3	RW	Word		0...2	num
V6	V6-L02	Setpoint synchronization	36226	0	38770	12	RW	Word		0...1	num
V6	V6-L03	Defrost synchronization	36227	0	38770	48	RW	Word		0...2	num
V6	V6-L04	Inhibit resources at the end of defrost	36228	0	38770	192	RW	Word		0...1	num
V6	V6-L05	Stand-by synchronization	36229	0	38770	768	RW	Word		0...1	num
V6	V6-L06	Lights synchronization	36230	0	38770	3072	RW	Word		0...1	num
V6	V6-L07	Reduced set synchronization	36231	0	38770	12288	RW	Word		0...1	num
V6	V6-L08	AUX synchronization	36232	0	38770	49152	RW	Word		0...1	num
V6	V6-L09	Shared saturation probe	36233	0	38771	3	RW	Word		0...1	num
V6	V6-L10	Resource unlocking timeout during synchronized defrosts	36484	0	38771	12	RW	Word		0...250	min
V6	V6-L11	Number of devices connected in Link2	36234	0	38788	48	RW	Word		0...8	num
V6	V6-L12	Alarm relay sharing in Link2	36235	0	38788	192	RW	Word		0...2	num
V6	V6-L13	Link2 serial frame configuration	36495	0	38787	12288	RW	Word		0...2	num
V6	V6-L14	Force cool mode	36511	0	38790	3	RW	Word		0...1	num
V6	V6-dcS	Deep cooling setpoint	36418	0	38771	768	RW	Word	Y	-58.0...302.0	°C/°F
V6	V6-tdc	Deep cooling duration	36419	0	38771	3072	RW	Word		0...250	min
V6	V6-dcc	Defrost delay after deep cooling	36420	0	38771	12288	RW	Word		0...250	min
V6	V6-ESt	Type of action for the Energy Saving function	36347	0	38771	49152	RW	Word		0...8	num
V6	V6-ESF	Night mode activation (Energy Saving)	36415	0	38772	3	RW	Word		0...1	num
V6	V6-Cdt	Door closing time	36416	0	38772	12	RW	Word		0...255	min*10
V6	V6-ESo	Low consumption mode disabling timeout (door switch)	36417	0	38772	48	RW	Word		0...10	num
V6	V6-OS1	Offset on setpoint 1	36364	0	38772	192	RW	Word	Y	-50.0...50.0	°C/°F
V6	V6-OS2	Offset on setpoint 2	36365	0	38772	768	RW	Word	Y	-50.0...50.0	°C/°F
V6	V6-Od1	Refrigerated cabinets energy saving offset 1	36366	0	38772	3072	RW	Word	Y	-50.0...50.0	°C/°F
V6	V6-Od2	Refrigerated cabinets energy saving offset 2	36367	0	38772	12288	RW	Word	Y	-50.0...50.0	°C/°F
V6	V6-dn1	Differential during energy saving mode 1	36355	0	38772	49152	RW	Word	Y	-58.0...302.0	°C/°F
V6	V6-dn2	Differential during energy saving mode 2	36356	0	38773	3	RW	Word	Y	-58.0...302.0	°C/°F
V6	V6-EdH	Weekday energy saving start hour	36341	0	38773	12	RW	Word		0...24	h
V6	V6-Edn	Weekday energy saving start minutes	36342	0	38773	48	RW	Word		0...59	min
V6	V6-Edd	Weekday energy saving duration	36343	0	38773	192	RW	Word		1...72	h

V6	V6-EFH	Weekend/holiday energy saving start hour	36344	0	38773	768	RW	Word		0...24	h
V6	V6-EFn	Weekend/holiday energy saving start minutes	36345	0	38773	3072	RW	Word		0...59	min
V6	V6-EFd	Weekend/holiday energy saving duration	36346	0	38773	12288	RW	Word		1...72	h
V6	V6-FH	Frame heater probe selection	36447	0	38773	49152	RW	Word		0...9	num
V6	V6-FHt	Frame heater period	36449	0	38774	3	RW	Word		1...2500	s
V6	V6-FH0	Frame heater set	36450	0	38774	12	RW	Word	Y	-58.0...302.0	°C/°F
V6	V6-FH1	Frame heater offset	36451	0	38774	48	RW	Word		0...25.0	°C/°F
V6	V6-FH2	Frame heater band	36452	0	38774	192	RW	Word	Y	-58.0...302.0	°C/°F
V6	V6-FH3	Frame heater minimum percentage/duty-cycle	36453	0	38774	768	RW	Word		0...100	%
V6	V6-FH4	Frame heater maximum percentage/day duty-cycle	36454	0	38774	3072	RW	Word		0...100	%
V6	V6-FH5	Frame heater maximum percentage/night duty-cycle	36455	0	38774	12288	RW	Word		0...100	%
V6	V6-FH6	Frame heater percentage/duty-cycle in defrost	36456	0	38774	49152	RW	Word		0...100	%
V6	V6-LOC	Disable terminal	36459	0	38775	3	RW	Word		0...1	num
V6	V6-PS1	Password 1 value	36460	0	38775	12	RW	Word		0...250	num
V6	V6-PS2	Password 2 value	36461	0	38775	48	RW	Word		0...250	num
V6	V6-ndt	Display with decimal point	36462	0	38775	192	RW	Word		0...1	num
V6	V6-CA1	Analog input 1 calibration	36268	0	38775	768	RW	Word	Y	-30.0...30.0	°C/°F
V6	V6-CA2	Analog input 2 calibration	36269	0	38775	3072	RW	Word	Y	-30.0...30.0	°C/°F
V6	V6-CA3	Analog input 3 calibration	36270	0	38775	12288	RW	Word	Y	-30.0...30.0	°C/°F
V6	V6-CA4	Analog input 4 calibration	36271	0	38775	49152	RW	Word	Y	-30.0...30.0	°C/°F
V6	V6-CA5	Analog input 5 calibration	36272	0	38776	3	RW	Word	Y	-30.0...30.0	°C/°F
V6	V6-CA6	Analog input 6 calibration	36273	0	38776	12	RW	Word	Y	-30...30	bar/psi
V6	V6-CA7	Analog input 7 calibration	36274	0	38776	48	RW	Word	Y	-30...30	bar/psi
V6	V6-LdL	Minimum display value	36463	0	38776	192	RW	Word	Y	-58.0...V6-HdL	°C/°F
V6	V6-HdL	Maximum display value	36464	0	38776	768	RW	Word	Y	V6-LdL...302.0	°C/°F
V6	V6-ddL	Display lock mode during a defrost	36465	0	38776	3072	RW	Word		0...2	num
V6	V6-Ldd	Display lock timeout from end of defrost	36466	0	38776	12288	RW	Word		0...250	min
V6	V6-dro	Select °C / °F	36467	0	38776	49152	RW	Word		0...1	num
V6	V6-SbP	Pressure unit of measure	36468	0	38777	3	RW	Word		0...1	num
V6	V6-ddd	Select main display value	36469	0	38777	12	RW	Word		0...8	num

V6	V6-ddE	Resource displayed on ECHO	36470	0	38777	48	RW	Word		0...9	num
V6	V6-rPH	Receiver maximum valve opening %	36421	0	38777	192	RW	Word		0...5	num
V6	V6-H00	Select analog input type NTC/PTC	36236	0	38777	768	RW	Word		0...2	num
V6	V6-H02	Function activation time from terminal	36471	0	38777	3072	RW	Word		0...250	s
V6	V6-H08	Stand-by operating mode	36473	0	38777	12288	RW	Word		0...2	num
V6	V6-H11	Digital input 1 configurability and polarity	36239	0	38777	49152	RW	Word	Y	-18...18	num
V6	V6-H12	Digital input 2 configurability and polarity	36240	0	38778	3	RW	Word	Y	-18...18	num
V6	V6-H13	Digital input 3 configurability and polarity	36241	0	38778	12	RW	Word	Y	-18...18	num
V6	V6-H14	Digital input 4 configurability and polarity	36242	0	38778	48	RW	Word	Y	-18...18	num
V6	V6-H15	Digital input 5 configurability and polarity	36243	0	38778	192	RW	Word	Y	-18...18	num
V6	V6-H16	Digital input 6 configurability and polarity	36244	0	38778	768	RW	Word	Y	-18...18	num
V6	V6-H17	Digital input 7 configurability and polarity	36245	0	38778	3072	RW	Word	Y	-18...18	num
V6	V6-H18	Digital input 8 configurability and polarity	36246	0	38778	12288	RW	Word	Y	-18...18	num
V6	V6-i01	Digital input 9 configurability and polarity	36506	0	38789	192	RW	Word	Y	-18...18	num
V6	V6-i02	Digital input 10 configurability and polarity	36507	0	38789	768	RW	Word	Y	-18...18	num
V6	V6-dti	Digital inputs 1 and 2 delay unit of measure	36255	0	38778	49152	RW	Word		0...1	num
V6	V6-d11	D.I. 1 activation indication delay time	36247	0	38779	3	RW	Word		0...255	min/s
V6	V6-d12	D.I. 2 activation indication delay time	36248	0	38779	12	RW	Word		0...255	min/s
V6	V6-d13	D.I. 3 activation indication delay time	36249	0	38779	48	RW	Word		0...255	min
V6	V6-d14	D.I. 4 activation indication delay time	36250	0	38779	192	RW	Word		0...255	min
V6	V6-d15	D.I. 5 activation indication delay time	36251	0	38779	768	RW	Word		0...255	min
V6	V6-d16	D.I. 6 activation indication delay time	36252	0	38779	3072	RW	Word		0...255	min
V6	V6-d17	D.I. 7 activation indication delay time	36253	0	38779	12288	RW	Word		0...255	min
V6	V6-d18	D.I. 8 activation indication delay time	36254	0	38779	49152	RW	Word		0...255	min
V6	V6-01i	D.I. 9 activation indication delay time	36508	0	38789	3072	RW	Word		0...255	min/s
V6	V6-02i	D.I. 10 activation indication delay time	36509	0	38789	12288	RW	Word		0...255	min

V6	V6-H21	Configurability of digital output 1	36276	0	38780	3	RW	Word		0...19	num
V6	V6-H22	Configurability of digital output 2	36277	0	38780	12	RW	Word		0...19	num
V6	V6-H23	Configurability of digital output 3	36278	0	38780	48	RW	Word		0...19	num
V6	V6-H24	Configurability of digital output 4	36279	0	38780	192	RW	Word		0...19	num
V6	V6-H25	Configurability of digital output 5	36280	0	38780	768	RW	Word		0...19	num
V6	V6-H27	Configurability of digital output 7	36282	0	38780	12288	RW	Word		0...19	num
V6	V6-H29	Enable buzzer	36283	0	38780	49152	RW	Word		0...1	num
V6	V6-d01	Configurability of digital output 8	36499	0	38788	768	RW	Word		0...19	num
V6	V6-d02	Configurability of digital output 9	36500	0	38788	3072	RW	Word		0...19	num
V6	V6-H31	Configurability of the UP key	36474	0	38781	3	RW	Word		0...9	num
V6	V6-H32	Configurability of the DOWN key	36475	0	38781	12	RW	Word		0...9	num
V6	V6-H33	Configurability of the ESC key	36476	0	38781	48	RW	Word		0...9	num
V6	V6-H34	Configurability of the Free 1 key	36477	0	38781	192	RW	Word		0...9	num
V6	V6-H35	Configurability of the Free 2 key	36478	0	38781	768	RW	Word		0...9	num
V6	V6-H36	Configurability of the Free 3 key	36479	0	38781	3072	RW	Word		0...9	num
V6	V6-H37	Configurability of the Free 4 key	36480	0	38781	12288	RW	Word		0...9	num
V6	V6-H41	Analog input 1 calibration	36256	0	38781	49152	RW	Word		0...2	num
V6	V6-H42	Analog input 2 calibration	36257	0	38782	3	RW	Word		0...2	num
V6	V6-H43	Analog input 3 calibration	36258	0	38782	12	RW	Word		0...2	num
V6	V6-H44	Analog input 4 calibration	36259	0	38782	48	RW	Word		0...2	num
V6	V6-H45	Analog input 5 calibration	36260	0	38782	192	RW	Word		0...2	num
V6	V6-H46	Analog input 6 calibration	36261	0	38782	768	RW	Word		0...2	num
V6	V6-H47	Analog input 7 calibration	36262	0	38782	3072	RW	Word		0...2	num
V6	V6-H48	Analog input 8 calibration	36510	0	38789	49152	RW	Word		0...2	num
V6	V6-H50	Configurability of analog output 1	36284	0	38782	12288	RW	Word		0...1	num
V6	V6-H51	Function associated with analog output	36285	0	38782	49152	RW	Word		0...3	num
V6	V6-H68	RTC present	36286	0	38783	3	RW	Word		0...1	num
V6	V6-H70	Selection of 1st sensor for virtual probe	36264	0	38783	12	RW	Word		0...5	num
V6	V6-H71	Selection of 2nd sensor for virtual probe	36265	0	38783	48	RW	Word		0...5	num
V6	V6-H72	Day virtual probe calculation %	36266	0	38783	192	RW	Word		0...100	%
V6	V6-H73	Night virtual probe calculation %	36267	0	38783	768	RW	Word		0...100	%

V6	V6-H74	Selection of 1st sensor for filtered virtual probe	36496	0	38787	49152	RW	Word		0...65635	num
V6	V6-H75	Percentage in thousandths of the incoming signal for filtered virtual probe	36497	0	38788	3	RW	Word		0...6563.5	num
V6	V6-H76	Filtered virtual probe offset	36498	0	38788	12	RW	Word		0...6563.5	num
V6	V6-EtY	Selection of electronic expansion valve driver	36481	0	38783	3072	RW	Word		0...2	num
V6	V6-OHP	Selection of oil temperature probe	36488	0	38786	12288	RW	Word		0...8	num
V6	V6-OSP	Oil heater setpoint	36489	0	38786	49152	RW	Word	Y	V6-OLS...V6-OHS	°C/°F
V6	V6-OHd	Oil heater differential	36490	0	38787	3	RW	Word		.1...25.0	°C/°F
V6	V6-OHS	Maximum oil heater setpoint value that can be set	36492	0	38787	48	RW	Word	Y	V6-OLS...302.0	°C/°F
V6	V6-OLS	Minimum oil heater setpoint value that can be set	36493	0	38787	192	RW	Word	Y	-58.0...V6-OHS	°C/°F
V6	UL	Visibility of parameter transfer function (Device -> UNICARD/MFK)	-	-	38786	3	RW	Word		0...3	num
V6	dL	Visibility of parameter transfer function (UNICARD/MFK -> Device)	-	-	38786	12	RW	Word		0...3	num
V6	Fr	Visibility of UNICARD/MFK formatting function	-	-	38786	48	RW	Word		0...3	num

Application 7 parameters

V7	V7-rE	Regulation type	36732	0	38848	3	RW	Word		0...6	num
V7	V7-rP1	Thermostat regulation probe 1	36733	0	38848	12	RW	Word		0...8	num
V7	V7-rP2	Thermostat regulation probe 2	36734	0	38848	48	RW	Word		0...9	num
V7	V7-SP1	Regulation setpoint 1	36735	0	38848	192	RW	Word	Y	V7-LS1...V7-HS1	°C/°F
V7	V7-dF1	Setpoint differential 1	36736	0	38848	768	RW	Word	Y	-58.0...302.0	°C/°F
V7	V7-SP2	Regulation setpoint 2	36737	0	38848	3072	RW	Word	Y	V7-LS2...V7-HS2	°C/°F
V7	V7-dF2	Setpoint differential 2	36738	0	38848	12288	RW	Word	Y	-58.0...302.0	°C/°F
V7	V7-Stt	Differential management mode	36741	0	38848	49152	RW	Word		0...1	num
V7	V7-HS1	Maximum value that can be set for Setpoint 1	36744	0	38849	3	RW	Word	Y	V7-LS1...V7-HdL	°C/°F
V7	V7-LS1	Minimum value that can be set for Setpoint 1	36745	0	38849	12	RW	Word	Y	V7-LdL...V7-HS1	°C/°F
V7	V7-HS2	Maximum value that can be set for Setpoint 2	36746	0	38849	48	RW	Word	Y	V7-LS2...V7-HdL	°C/°F
V7	V7-LS2	Minimum value that can be set for Setpoint 2	36747	0	38849	192	RW	Word	Y	V7-LdL...V7-HS2	°C/°F
V7	V7-HC1	Setpoint 1 operating mode (Heating/Cooling)	36742	0	38849	768	RW	Word		0...1	num
V7	V7-HC2	Setpoint 2 operating mode (Heating/Cooling)	36743	0	38849	3072	RW	Word		0...1	num

Application 7 parameters											
V7	V7-Cit	Minimum compressor output activation time	36752	0	38849	49152	RW	Word		0...250	min
V7	V7-CAt	Maximum compressor output activation time	36753	0	38850	3	RW	Word		0...250	min
V7	V7-Ont	Compressor output ON time if regulation probe is faulty	36758	0	38850	12	RW	Word		0...250	min
V7	V7-OFt	Compressor output OFF time if regulation probe is faulty	36759	0	38850	48	RW	Word		0...250	min
V7	V7-dOn	Compressor output activation delay from call	36754	0	38850	192	RW	Word		0...250	s
V7	V7-dOF	Compressor output activation delay from switch-off	36755	0	38850	768	RW	Word		0...250	min
V7	V7-dbi	Delay between two consecutive compressor output power-ons	36756	0	38850	3072	RW	Word		0...250	min
V7	V7-OdO	Output activation delay at startup	36757	0	38850	12288	RW	Word		0...250	min
V7	V7-CFP	Condenser pre-ventilation time in Heat/Cool	36841	0	38851	12	RW	Word		0...255	s
V7	V7-CFd	Condenser fan cut-out during defrosting.	36842	0	38851	48	RW	Word		0...1	num
V7	V7-OF1	Remote offset	36763	0	38851	192	RW	Word	Y	-50.0...50.0	°C/°F
V7	V7-Pot	Pump down time	36869	0	38882	192	RW	Word		0...250	s
V7	V7-SS1	Compressor softstart: advance hotgas valve opening	36870	0	38882	768	RW	Word		0...250	s
V7	V7-SS2	Compressor softstart: delay hotgas valve closing	36871	0	38882	3072	RW	Word		0...250	s
V7	V7-dP1	Select defrost probe 1	36764	0	38851	768	RW	Word		0...8	num
V7	V7-dP2	Defrost probe 2 selection	36765	0	38851	3072	RW	Word		0...8	num
V7	V7-dtY	Type of defrost	36768	0	38851	12288	RW	Word		0...4	num
V7	V7-dFt	Dual evaporator defrost activation mode	36766	0	38851	49152	RW	Word		0...2	num
V7	V7-dit	Interval between defrosts	36769	0	38852	3	RW	Word		0...250	h/min/s
V7	V7-dt1	Unit of measure for defrost intervals	36772	0	38852	12	RW	Word		0...2	num
V7	V7-dt2	Unit of measure for defrost duration	36773	0	38852	48	RW	Word		0...2	num
V7	V7-dCt	Defrost interval count mode	36767	0	38852	192	RW	Word		0...5	num
V7	V7-dOH	Defrost cycle activation delay from the call	36774	0	38852	768	RW	Word		0...250	min
V7	V7-dE1	Evaporator 1 defrost maximum duration	36770	0	38852	3072	RW	Word		1...250	h/min/s
V7	V7-dE2	Evaporator 2 defrost maximum duration	36771	0	38852	12288	RW	Word		1...250	h/min/s
V7	V7-dS1	Evaporator 1 defrost end temperature	36776	0	38852	49152	RW	Word	Y	-58.0...302.0	°C/°F
V7	V7-dS2	Evaporator 2 defrost end temperature	36777	0	38853	3	RW	Word	Y	-58.0...302.0	°C/°F

Application 7 parameters											
V7	V7-dSS	Temperature threshold for starting defrost	36775	0	38853	12	RW	Word	Y	-58.0...302.0	°C/°F
V7	V7-dPO	Defrost activation request at power-on	36778	0	38853	48	RW	Word		0...1	num
V7	V7-tcd	Compressor output activation/deactivation time before a defrost	36779	0	38853	192	RW	Word	Y	-60...60	min
V7	V7-ndE	minimum defrost duration time	36780	0	38853	768	RW	Word		0...250	h/min/s
V7	V7-PdC	Hot gas extraction time at the end of the defrost	36781	0	38853	3072	RW	Word		0...250	min
V7	V7-tPd	Pump down time before defrost start	36783	0	38853	12288	RW	Word		0...255	min
V7	V7-dPH	Regular defrost start hour	36722	0	38853	49152	RW	Word		0...24	h
V7	V7-dPn	Regular defrost start minutes	36723	0	38854	3	RW	Word		0...59	min
V7	V7-dPd	Regular defrost interval duration	36724	0	38854	12	RW	Word		1...7	day
V7	V7-Fd1	1st weekend/holiday day	36671	0	38854	48	RW	Word		0...7	num
V7	V7-Fd2	2nd weekend/holiday day	36672	0	38854	192	RW	Word		0...7	num
V7	V7-Edt	Timeout and defrost end temperature specific to each event	36673	0	38854	768	RW	Word		0...1	num
V7	V7-PrH	Basin heater pre-activation time	36878	0	38883	3072	RW	Word		0...255	min
V7	V7-Fdn	Weekday defrost number	36621	0	38888	3	RW	Word		0...250	num
V7	V7-FFn	Weekend/holiday defrost number	36622	0	38888	12	RW	Word		0...250	num
V7	V7-d1H	Weekday defrost no. 1 start hour	36674	0	38854	3072	RW	Word		0...24	h
V7	V7-d1n	Weekday defrost no. 1 start minute	36675	0	38854	12288	RW	Word		0...59	min
V7	V7-d1t	1st weekday defrost duration	36676	0	38854	49152	RW	Word		0...250	min
V7	V7-d1S	1st weekday defrost end temperature	36677	0	38855	3	RW	Word	Y	-58.0...302.0	°C/°F
V7	V7-d2H	Weekday defrost no. 2 start hour	36678	0	38855	12	RW	Word		V7-d1H...24	h
V7	V7-d2n	Weekday defrost no. 2 start minutes	36679	0	38855	48	RW	Word		0...59	min
V7	V7-d2t	2nd weekday defrost duration	36680	0	38855	192	RW	Word		0...250	min
V7	V7-d2S	2nd weekday defrost end temperature	36681	0	38855	768	RW	Word	Y	-58.0...302.0	°C/°F
V7	V7-d3H	Weekday defrost no. 3 start hour	36682	0	38855	3072	RW	Word		V7-d2H...24	h
V7	V7-d3n	Weekday defrost no. 3 start minutes	36683	0	38855	12288	RW	Word		0...59	min
V7	V7-d3t	3rd weekday defrost duration	36684	0	38855	49152	RW	Word		0...250	min
V7	V7-d3S	3rd weekday defrost end temperature	36685	0	38856	3	RW	Word	Y	-58.0...302.0	°C/°F
V7	V7-d4H	Weekday defrost no. 4 start hour	36686	0	38856	12	RW	Word		V7-d3H...24	h

Application 7 parameters											
V7	V7-d4n	Weekday defrost no. 4 start minutes	36687	0	38856	48	RW	Word		0...59	min
V7	V7-d4t	4th weekday defrost duration	36688	0	38856	192	RW	Word		0...250	min
V7	V7-d4S	4th weekday defrost end temperature	36689	0	38856	768	RW	Word	Y	-58.0...302.0	°C/°F
V7	V7-d5H	Weekday defrost no. 5 start hour	36690	0	38856	3072	RW	Word		V7-d4H...24	h
V7	V7-d5n	Weekday defrost no. 5 start minutes	36691	0	38856	12288	RW	Word		0...59	min
V7	V7-d5t	5th weekday defrost duration	36692	0	38856	49152	RW	Word		0...250	min
V7	V7-d5S	5th weekday defrost end temperature	36693	0	38857	3	RW	Word	Y	-58.0...302.0	°C/°F
V7	V7-d6H	Weekday defrost no. 6 start hour	36694	0	38857	12	RW	Word		V7-d5H...24	h
V7	V7-d6n	Weekday defrost no. 6 start minutes	36695	0	38857	48	RW	Word		0...59	min
V7	V7-d6t	6th weekday defrost duration	36696	0	38857	192	RW	Word		0...250	min
V7	V7-d6S	6th weekday defrost end temperature	36697	0	38857	768	RW	Word	Y	-58.0...302.0	°C/°F
V7	V7-F1H	Weekend/holiday defrost no. 1 start hour	36698	0	38857	3072	RW	Word		0...24	h
V7	V7-F1n	Weekend/holiday defrost no. 1 start minute	36699	0	38857	12288	RW	Word		0...59	min
V7	V7-F1t	1st weekend/holiday defrost duration	36700	0	38857	49152	RW	Word		0...250	min
V7	V7-F1S	1st weekend/holiday defrost end temperature	36701	0	38858	3	RW	Word	Y	-58.0...302.0	°C/°F
V7	V7-F2H	Weekend/holiday defrost no. 2 start hour	36702	0	38858	12	RW	Word		V7-F1H...24	h
V7	V7-F2n	Weekend/holiday defrost no. 2 start minutes	36703	0	38858	48	RW	Word		0...59	min
V7	V7-F2t	2nd weekend/holiday defrost duration	36704	0	38858	192	RW	Word		0...250	min
V7	V7-F2S	2nd weekend/holiday defrost end temperature	36705	0	38858	768	RW	Word	Y	-58.0...302.0	°C/°F
V7	V7-F3H	Weekend/holiday defrost no. 3 start hour	36706	0	38858	3072	RW	Word		V7-F2H...24	h
V7	V7-F3n	Weekend/holiday defrost no. 3 start minutes	36707	0	38858	12288	RW	Word		0...59	min
V7	V7-F3t	3rd weekend/holiday defrost duration	36708	0	38858	49152	RW	Word		0...250	min
V7	V7-F3S	3rd weekend/holiday defrost end temperature	36709	0	38859	3	RW	Word	Y	-58.0...302.0	°C/°F
V7	V7-F4H	Weekend/holiday defrost no. 4 start hour	36710	0	38859	12	RW	Word		V7-F3H...24	h
V7	V7-F4n	Weekend/holiday defrost no. 4 start minutes	36711	0	38859	48	RW	Word		0...59	min

Application 7 parameters											
V7	V7-F4t	4th weekend/holiday defrost duration	36712	0	38859	192	RW	Word		0...250	min
V7	V7-F4S	4th weekend/holiday defrost end temperature	36713	0	38859	768	RW	Word	Y	-58.0...302.0	°C/°F
V7	V7-F5H	Weekend/holiday defrost no. 5 start hour	36714	0	38859	3072	RW	Word		V7-F4H...24	h
V7	V7-F5n	Weekend/holiday defrost no. 5 start minutes	36715	0	38859	12288	RW	Word		0...59	min
V7	V7-F5t	5th weekend/holiday defrost duration	36716	0	38859	49152	RW	Word		0...250	min
V7	V7-F5S	5th weekend/holiday defrost end temperature	36717	0	38860	3	RW	Word	Y	-58.0...302.0	°C/°F
V7	V7-F6H	Weekend/holiday defrost no. 6 start hour	36718	0	38860	12	RW	Word		V7-F5H...24	h
V7	V7-F6n	Weekend/holiday defrost no. 6 start minutes	36719	0	38860	48	RW	Word		0...59	min
V7	V7-F6t	6th weekend/holiday defrost duration	36720	0	38860	192	RW	Word		0...250	min
V7	V7-F6S	6th weekend/holiday defrost end temperature	36721	0	38860	768	RW	Word	Y	-58.0...302.0	°C/°F
V7	V7-FP1	Selection of evaporator fan probe in normal mode	36784	0	38860	3072	RW	Word		0...7	num
V7	V7-FP2	Selection of evaporator fan probe in defrost	36785	0	38860	12288	RW	Word		0...7	num
V7	V7-FPt	FSt parameter mode (absolute or relative)	36786	0	38860	49152	RW	Word		0...1	num
V7	V7-FSt	Evaporator fan disabling temperature	36787	0	38861	3	RW	Word	Y	-58.0...302.0	°C/°F
V7	V7-FAAd	Evaporator fan trigger differential	36788	0	38861	12	RW	Word		.1...25.0	°C/°F
V7	V7-Fdt	Evaporator fan activation delay time after a defrost cycle	36789	0	38861	48	RW	Word		0...250	min
V7	V7-dt	Dripping time	36794	0	38861	192	RW	Word		0...250	min
V7	V7-dFd	Evaporator fan cut-out during defrost	36792	0	38861	768	RW	Word		0...1	num
V7	V7-FCO	Evaporator fan status with compressor output Off	36791	0	38861	3072	RW	Word		0...4	num
V7	V7-Fod	Evaporator fan status with door open	36793	0	38861	12288	RW	Word		0...1	num
V7	V7-FdC	Evaporator fan shutoff delay after compressor deactivation	36790	0	38861	49152	RW	Word		0...250	min
V7	V7-FOn	Evaporator fan On time in cyclical regulator mode	36795	0	38862	3	RW	Word		0...250	min
V7	V7-FOF	Evaporator fan Off time in cyclical regulator mode	36796	0	38862	12	RW	Word		0...250	min
V7	V7-Fnn	Evaporator fan ON time in night mode (duty cycle)	36797	0	38862	48	RW	Word		0...250	min

Application 7 parameters											
V7	V7-FnF	Evaporator fan OFF time in night mode (duty cycle)	36798	0	38862	192	RW	Word		0...250	min
V7	V7-FE1	Variable speed fan probe selection	36897	0	38886	48	RW	Word		0...12	num
V7	V7-FE1	Setpoint mode	36898	0	38886	192	RW	Word		0...1	num
V7	V7-FES	Setpoint	36899	0	38886	768	RW	Word	Y	-58...302	num
V7	V7-FEd	Band	36900	0	38886	3072	RW	Word		0.1...50	num
V7	V7-FEu	Cut-off band	36901	0	38886	12288	RW	Word		0...25	num
V7	V7-FEC	Cut-off differential	36902	0	38886	49152	RW	Word		0.1...25	num
V7	V7-FEr	Fan shutoff delay after compressor deactivation	36903	0	38887	3	RW	Word		0...250	min
V7	V7-FE2	Minimum day percentage	36904	0	38887	12	RW	Word		0...100	%
V7	V7-FE3	Maximum day percentage with compressor on	36905	0	38887	48	RW	Word		0...100	%
V7	V7-FE4	Maximum day percentage with compressor off	36906	0	38887	192	RW	Word		0...100	%
V7	V7-FE5	Minimum night percentage	36907	0	38887	768	RW	Word		0...100	%
V7	V7-FE6	Maximum night percentage with compressor on	36908	0	38887	3072	RW	Word		0...100	%
V7	V7-FE7	Maximum night percentage with compressor off	36909	0	38887	12288	RW	Word		0...100	%
V7	V7-FE8	Percentage during defrost	36910	0	38887	49152	RW	Word		0...100	%
V7	V7-FE9	Percentage in the event of probe error	36911	0	38899	12	RW	Word		0...100	%
V7	V7-FEA	Maximum pick-up speed	36912	0	38899	48	RW	Word		0...100	%
V7	V7-FEb	Fan pick-up time	36913	0	38899	192	RW	Word		0...250	s
V7	V7-FEP	Fan forcing period at pick-up speed	36914	0	38899	768	RW	Word		0...250	min
V7	V7-rA1	Temperature alarm probe 1 selection	36812	0	38862	768	RW	Word		0...7	num
V7	V7-rA2	Temperature alarm probe 2 selection	36813	0	38862	3072	RW	Word		0...7	num
V7	V7-Att	Alarm mode (absolute or relative)	36814	0	38862	12288	RW	Word		0...1	num
V7	V7-AFd	Alarm activation differential	36815	0	38862	49152	RW	Word		.1...25.0	°C/°F
V7	V7-HA1	Maximum alarm 1 threshold	36816	0	38863	3	RW	Word	Y	V7-LA1...302.0	°C/°F
V7	V7-LA1	Minimum alarm 1 threshold	36817	0	38863	12	RW	Word	Y	-58.0...V7-HA1	°C/°F
V7	V7-HA2	Maximum alarm 2 threshold	36818	0	38863	48	RW	Word	Y	V7-LA2...302.0	°C/°F
V7	V7-LA2	Minimum alarm 2 threshold	36819	0	38863	192	RW	Word	Y	-58.0...V7-HA2	°C/°F
V7	V7-PAO	Temperature alarm exclusion time from power-on	36820	0	38863	768	RW	Word		0...10	h
V7	V7-dAO	Exclusion time for temperature alarms after a defrost cycle	36822	0	38863	3072	RW	Word		0...250	min

Application 7 parameters											
V7	V7-OAO	High and low temperature alarms exclusion time after closing the door	36821	0	38863	12288	RW	Word		0...10	h
V7	V7-tdO	Door open alarm exclusion time	36866	0	38863	49152	RW	Word		0...250	num
V7	V7-tA1	Probe 1 High/Minimum Alarm Delay	36823	0	38864	3	RW	Word		0...250	min
V7	V7-tA2	Probe 2 High/Minimum Alarm Delay	36824	0	38864	12	RW	Word		0...250	min
V7	V7-dAt	Defrost ended due to timeout alarm signaling	36782	0	38864	48	RW	Word		0...1	num
V7	V7-EAL	Regulators inhibited by external alarm	36826	0	38864	192	RW	Word		0...2	num
V7	V7-rA3	Leak detection probe selection	36885	0	38884	12288	RW	Word		0...8	num
V7	V7-ALL	Low threshold leak alarm	36886	0	38884	49152	RW	Word		0...V7-ALH	num
V7	V7-ALH	High threshold leak alarm	36887	0	38885	3	RW	Word		V7-ALL...100	num
V7	V7-dAL	Alarm leak differential	36888	0	38885	12	RW	Word		0.1...100	num
V7	V7-AL1	Time probe remains above the low threshold due to leak alarm activation	36889	0	38885	48	RW	Word		0...250	min
V7	V7-AL2	Time probe remains above the high threshold due to leak alarm activation	36896	0	38886	12	RW	Word		0...250	min
V7	V7-tP	Enables alarm acknowledgment with any key	36867	0	38864	768	RW	Word		0...1	num
V7	V7-Art	Regular watchdog alarm activation period	36811	0	38864	3072	RW	Word		0...250	min*10
V7	V7-dSd	Enable light relay from door switch	36808	0	38864	12288	RW	Word		0...1	num
V7	V7-dLt	Light relay off delay from door closure	36809	0	38864	49152	RW	Word		0...250	min
V7	V7-OFL	Enable cold room lights off via key during the delay set in parameter dLt	36810	0	38865	3	RW	Word		0...1	num
V7	V7-dOd	Enable utility shutoff upon door switch activation	36825	0	38865	12	RW	Word		0...3	num
V7	V7-dOA	Behavior forced by digital input	36827	0	38865	48	RW	Word		0...5	num
V7	V7-PEA	Enable forced behavior from door switch and/or external alarm.	36828	0	38865	192	RW	Word		0...3	num
V7	V7-dCO	Compressor activation delay from acknowledgment	36829	0	38865	768	RW	Word		0...250	min
V7	V7-dFO	Fan enabling delay from acknowledgment	36830	0	38865	3072	RW	Word		0...250	min
V7	V7-ASb	Instrument off active light/auxiliary digital input or key	36856	0	38865	12288	RW	Word		0...1	num

Application 7 parameters											
V7	V7-L00	Shared probe	36608	0	38865	49152	RW	Word		0...7	num
V7	V7-L01	Distributed viewing (refers to slave)	36609	0	38866	3	RW	Word		0...2	num
V7	V7-L02	Setpoint synchronization	36610	0	38866	12	RW	Word		0...1	num
V7	V7-L03	Defrost synchronization	36611	0	38866	48	RW	Word		0...2	num
V7	V7-L04	Inhibit resources at the end of defrost	36612	0	38866	192	RW	Word		0...1	num
V7	V7-L05	Stand-by synchronization	36613	0	38866	768	RW	Word		0...1	num
V7	V7-L06	Lights synchronization	36614	0	38866	3072	RW	Word		0...1	num
V7	V7-L07	Reduced set synchronization	36615	0	38866	12288	RW	Word		0...1	num
V7	V7-L08	AUX synchronization	36616	0	38866	49152	RW	Word		0...1	num
V7	V7-L09	Shared saturation probe	36617	0	38867	3	RW	Word		0...1	num
V7	V7-L10	Resource unlocking timeout during synchronized defrosts	36868	0	38867	12	RW	Word		0...250	min
V7	V7-L11	Number of devices connected in Link2	36618	0	38884	48	RW	Word		0...8	num
V7	V7-L12	Alarm relay sharing in Link2	36619	0	38884	192	RW	Word		0...2	num
V7	V7-L13	Link2 serial frame configuration	36879	0	38883	12288	RW	Word		0...2	num
V7	V7-L14	Force cool mode	36895	0	38886	3	RW	Word		0...1	num
V7	V7-dcS	Deep cooling setpoint	36802	0	38867	768	RW	Word	Y	-58.0...302.0	°C/°F
V7	V7-tdc	Deep cooling duration	36803	0	38867	3072	RW	Word		0...250	min
V7	V7-dcc	Defrost delay after deep cooling	36804	0	38867	12288	RW	Word		0...250	min
V7	V7-ESt	Type of action for the Energy Saving function	36731	0	38867	49152	RW	Word		0...8	num
V7	V7-ESF	Night mode activation (Energy Saving)	36799	0	38868	3	RW	Word		0...1	num
V7	V7-Cdt	Door closing time	36800	0	38868	12	RW	Word		0...255	min*10
V7	V7-ESo	Low consumption mode disabling timeout (door switch)	36801	0	38868	48	RW	Word		0...10	num
V7	V7-OS1	Offset on setpoint 1	36748	0	38868	192	RW	Word	Y	-50.0...50.0	°C/°F
V7	V7-OS2	Offset on setpoint 2	36749	0	38868	768	RW	Word	Y	-50.0...50.0	°C/°F
V7	V7-Od1	Refrigerated cabinets energy saving offset 1	36750	0	38868	3072	RW	Word	Y	-50.0...50.0	°C/°F
V7	V7-Od2	Refrigerated cabinets energy saving offset 2	36751	0	38868	12288	RW	Word	Y	-50.0...50.0	°C/°F
V7	V7-dn1	Differential during energy saving mode 1	36739	0	38868	49152	RW	Word	Y	-58.0...302.0	°C/°F
V7	V7-dn2	Differential during energy saving mode 2	36740	0	38869	3	RW	Word	Y	-58.0...302.0	°C/°F
V7	V7-EdH	Weekday energy saving start hour	36725	0	38869	12	RW	Word		0...24	h
V7	V7-Edn	Weekday energy saving start minutes	36726	0	38869	48	RW	Word		0...59	min
V7	V7-Edd	Weekday energy saving duration	36727	0	38869	192	RW	Word		1...72	h
V7	V7-EFH	Weekend/holiday energy saving start hour	36728	0	38869	768	RW	Word		0...24	h

Application 7 parameters											
V7	V7-EFn	Weekend/holiday energy saving start minutes	36729	0	38869	3072	RW	Word		0...59	min
V7	V7-EFd	Weekend/holiday energy saving duration	36730	0	38869	12288	RW	Word		1...72	h
V7	V7-FH	Frame heater probe selection	36831	0	38869	49152	RW	Word		0...9	num
V7	V7-FHt	Frame heater period	36833	0	38870	3	RW	Word		1...2500	s
V7	V7-FH0	Frame heater set	36834	0	38870	12	RW	Word	Y	-58.0...302.0	°C/°F
V7	V7-FH1	Frame heater offset	36835	0	38870	48	RW	Word		0...25.0	°C/°F
V7	V7-FH2	Frame heater band	36836	0	38870	192	RW	Word	Y	-58.0...302.0	°C/°F
V7	V7-FH3	Frame heater minimum percentage/duty-cycle	36837	0	38870	768	RW	Word		0...100	%
V7	V7-FH4	Frame heater maximum percentage/day duty-cycle	36838	0	38870	3072	RW	Word		0...100	%
V7	V7-FH5	Frame heater maximum percentage/night duty-cycle	36839	0	38870	12288	RW	Word		0...100	%
V7	V7-FH6	Frame heater percentage/duty-cycle in defrost	36840	0	38870	49152	RW	Word		0...100	%
V7	V7-LOC	Disable terminal	36843	0	38871	3	RW	Word		0...1	num
V7	V7-PS1	Password 1 value	36844	0	38871	12	RW	Word		0...250	num
V7	V7-PS2	Password 2 value	36845	0	38871	48	RW	Word		0...250	num
V7	V7-ndt	Display with decimal point	36846	0	38871	192	RW	Word		0...1	num
V7	V7-CA1	Analog input 1 calibration	36652	0	38871	768	RW	Word	Y	-30.0...30.0	°C/°F
V7	V7-CA2	Analog input 2 calibration	36653	0	38871	3072	RW	Word	Y	-30.0...30.0	°C/°F
V7	V7-CA3	Analog input 3 calibration	36654	0	38871	12288	RW	Word	Y	-30.0...30.0	°C/°F
V7	V7-CA4	Analog input 4 calibration	36655	0	38871	49152	RW	Word	Y	-30.0...30.0	°C/°F
V7	V7-CA5	Analog input 5 calibration	36656	0	38872	3	RW	Word	Y	-30.0...30.0	°C/°F
V7	V7-CA6	Analog input 6 calibration	36657	0	38872	12	RW	Word	Y	-30...30	bar/psi
V7	V7-CA7	Analog input 7 calibration	36658	0	38872	48	RW	Word	Y	-30...30	bar/psi
V7	V7-LdL	Minimum display value	36847	0	38872	192	RW	Word	Y	-58.0...V7-HdL	°C/°F
V7	V7-HdL	Maximum display value	36848	0	38872	768	RW	Word	Y	V7-LdL...302.0	°C/°F
V7	V7-ddL	Display lock mode during a defrost	36849	0	38872	3072	RW	Word		0...2	num
V7	V7-Ldd	Display lock timeout from end of defrost	36850	0	38872	12288	RW	Word		0...250	min
V7	V7-dro	Select °C / °F	36851	0	38872	49152	RW	Word		0...1	num
V7	V7-SbP	Pressure unit of measure	36852	0	38873	3	RW	Word		0...1	num
V7	V7-ddd	Select main display value	36853	0	38873	12	RW	Word		0...8	num
V7	V7-ddE	Resource displayed on ECHO	36854	0	38873	48	RW	Word		0...9	num

Application 7 parameters											
V7	V7-rPH	Receiver maximum valve opening %	36805	0	38873	192	RW	Word		0...5	num
V7	V7-H00	Select analog input type NTC/PTC	36620	0	38873	768	RW	Word		0...2	num
V7	V7-H02	Function activation time from terminal	36855	0	38873	3072	RW	Word		0...250	s
V7	V7-H08	Stand-by operating mode	36857	0	38873	12288	RW	Word		0...2	num
V7	V7-H11	Digital input 1 configurability and polarity	36623	0	38873	49152	RW	Word	Y	-18...18	num
V7	V7-H12	Digital input 2 configurability and polarity	36624	0	38874	3	RW	Word	Y	-18...18	num
V7	V7-H13	Digital input 3 configurability and polarity	36625	0	38874	12	RW	Word	Y	-18...18	num
V7	V7-H14	Digital input 4 configurability and polarity	36626	0	38874	48	RW	Word	Y	-18...18	num
V7	V7-H15	Digital input 5 configurability and polarity	36627	0	38874	192	RW	Word	Y	-18...18	num
V7	V7-H16	Digital input 6 configurability and polarity	36628	0	38874	768	RW	Word	Y	-18...18	num
V7	V7-H17	Digital input 7 configurability and polarity	36629	0	38874	3072	RW	Word	Y	-18...18	num
V7	V7-H18	Digital input 8 configurability and polarity	36630	0	38874	12288	RW	Word	Y	-18...18	num
V7	V7-i01	Digital input 9 configurability and polarity	36890	0	38885	192	RW	Word	Y	-18...18	num
V7	V7-i02	Digital input 10 configurability and polarity	36891	0	38885	768	RW	Word	Y	-18...18	num
V7	V7-dti	Digital inputs 1 and 2 delay unit of measure	36639	0	38874	49152	RW	Word		0...1	num
V7	V7-d11	D.I. 1 activation indication delay time	36631	0	38875	3	RW	Word		0...255	min/s
V7	V7-d12	D.I. 2 activation indication delay time	36632	0	38875	12	RW	Word		0...255	min/s
V7	V7-d13	D.I. 3 activation indication delay time	36633	0	38875	48	RW	Word		0...255	min
V7	V7-d14	D.I. 4 activation indication delay time	36634	0	38875	192	RW	Word		0...255	min
V7	V7-d15	D.I. 5 activation indication delay time	36635	0	38875	768	RW	Word		0...255	min
V7	V7-d16	D.I. 6 activation indication delay time	36636	0	38875	3072	RW	Word		0...255	min
V7	V7-d17	D.I. 7 activation indication delay time	36637	0	38875	12288	RW	Word		0...255	min
V7	V7-d18	D.I. 8 activation indication delay time	36638	0	38875	49152	RW	Word		0...255	min
V7	V7-01i	D.I. 9 activation indication delay time	36892	0	38885	3072	RW	Word		0...255	min/s
V7	V7-02i	D.I. 10 activation indication delay time	36893	0	38885	12288	RW	Word		0...255	min
V7	V7-H21	Configurability of digital output 1	36660	0	38876	3	RW	Word		0...19	num

Application 7 parameters											
V7	V7-H22	Configurability of digital output 2	36661	0	38876	12	RW	Word		0...19	num
V7	V7-H23	Configurability of digital output 3	36662	0	38876	48	RW	Word		0...19	num
V7	V7-H24	Configurability of digital output 4	36663	0	38876	192	RW	Word		0...19	num
V7	V7-H25	Configurability of digital output 5	36664	0	38876	768	RW	Word		0...19	num
V7	V7-H27	Configurability of digital output 7	36666	0	38876	12288	RW	Word		0...19	num
V7	V7-H29	Enable buzzer	36667	0	38876	49152	RW	Word		0...1	num
V7	V7-d01	Configurability of digital output 8	36883	0	38884	768	RW	Word		0...19	num
V7	V7-d02	Configurability of digital output 9	36884	0	38884	3072	RW	Word		0...19	num
V7	V7-H31	Configurability of the UP key	36858	0	38877	3	RW	Word		0...9	num
V7	V7-H32	Configurability of the DOWN key	36859	0	38877	12	RW	Word		0...9	num
V7	V7-H33	Configurability of the ESC key	36860	0	38877	48	RW	Word		0...9	num
V7	V7-H34	Configurability of the Free 1 key	36861	0	38877	192	RW	Word		0...9	num
V7	V7-H35	Configurability of the Free 2 key	36862	0	38877	768	RW	Word		0...9	num
V7	V7-H36	Configurability of the Free 3 key	36863	0	38877	3072	RW	Word		0...9	num
V7	V7-H37	Configurability of the Free 4 key	36864	0	38877	12288	RW	Word		0...9	num
V7	V7-H41	Analog input 1 calibration	36640	0	38877	49152	RW	Word		0...2	num
V7	V7-H42	Analog input 2 calibration	36641	0	38878	3	RW	Word		0...2	num
V7	V7-H43	Analog input 3 calibration	36642	0	38878	12	RW	Word		0...2	num
V7	V7-H44	Analog input 4 calibration	36643	0	38878	48	RW	Word		0...2	num
V7	V7-H45	Analog input 5 calibration	36644	0	38878	192	RW	Word		0...2	num
V7	V7-H46	Analog input 6 calibration	36645	0	38878	768	RW	Word		0...2	num
V7	V7-H47	Analog input 7 calibration	36646	0	38878	3072	RW	Word		0...2	num
V7	V7-H48	Analog input 8 calibration	36894	0	38885	49152	RW	Word		0...2	num
V7	V7-H50	Configurability of analog output 1	36668	0	38878	12288	RW	Word		0...1	num
V7	V7-H51	Function associated with analog output	36669	0	38878	49152	RW	Word		0...3	num
V7	V7-H68	RTC present	36670	0	38879	3	RW	Word		0...1	num
V7	V7-H70	Selection of 1st sensor for virtual probe	36648	0	38879	12	RW	Word		0...5	num
V7	V7-H71	Selection of 2nd sensor for virtual probe	36649	0	38879	48	RW	Word		0...5	num
V7	V7-H72	Day virtual probe calculation %	36650	0	38879	192	RW	Word		0...100	%
V7	V7-H73	Night virtual probe calculation %	36651	0	38879	768	RW	Word		0...100	%

Application 7 parameters											
V7	V7-H74	Selection of 1st sensor for filtered virtual probe	36880	0	38883	49152	RW	Word		0...65635	num
V7	V7-H75	Percentage in thousandths of the incoming signal for filtered virtual probe	36881	0	38884	3	RW	Word		0...65635	num
V7	V7-H76	Filtered virtual probe offset	36882	0	38884	12	RW	Word		0...65635	num
V7	V7-EtY	Selection of electronic expansion valve driver	36865	0	38879	3072	RW	Word		0...2	num
V7	V7-OHP	Selection of oil temperature probe	36872	0	38882	12288	RW	Word		0...8	num
V7	V7-OSP	Oil heater setpoint	36873	0	38882	49152	RW	Word	Y	V7-OLS...V7-OHS	°C/°F
V7	V7-OHd	Oil heater differential	36874	0	38883	3	RW	Word		.1...25.0	°C/°F
V7	V7-OHS	Maximum oil heater setpoint value that can be set	36876	0	38883	48	RW	Word	Y	V7-OLS...302.0	°C/°F
V7	V7-OLS	Minimum oil heater setpoint value that can be set	36877	0	38883	192	RW	Word	Y	-58.0...V7-OHS	°C/°F
V7	UL	Visibility of parameter transfer function (Device -> UNICARD/MFK)	-	-	38882	3	RW	Word		0...3	num
V7	dL	Visibility of parameter transfer function (UNICARD/MFK -> Device)	-	-	38882	12	RW	Word		0...3	num
V7	Fr	Visibility of UNICARD/MFK formatting function	-	-	38882	48	RW	Word		0...3	num

Application 8 parameters											
V8	V8-rE	Regulation type	37116	0	38944	3	RW	Word		0...6	num
V8	V8-rP1	Thermostat regulation probe 1	37117	0	38944	12	RW	Word		0...8	num
V8	V8-rP2	Thermostat regulation probe 2	37118	0	38944	48	RW	Word		0...9	num
V8	V8-SP1	Regulation setpoint 1	37119	0	38944	192	RW	Word	Y	V8-LS1...V8-HS1	°C/°F
V8	V8-dF1	Setpoint differential 1	37120	0	38944	768	RW	Word	Y	-58.0...302.0	°C/°F
V8	V8-SP2	Regulation setpoint 2	37121	0	38944	3072	RW	Word	Y	V8-LS2...V8-HS2	°C/°F
V8	V8-dF2	Setpoint differential 2	37122	0	38944	12288	RW	Word	Y	-58.0...302.0	°C/°F
V8	V8-Stt	Differential management mode	37125	0	38944	49152	RW	Word		0...1	num
V8	V8-HS1	Maximum value that can be set for Setpoint 1	37128	0	38945	3	RW	Word	Y	V8-LS1...V8-HdL	°C/°F
V8	V8-LS1	Minimum value that can be set for Setpoint 1	37129	0	38945	12	RW	Word	Y	V8-LdL...V8-HS1	°C/°F
V8	V8-HS2	Maximum value that can be set for Setpoint 2	37130	0	38945	48	RW	Word	Y	V8-LS2...V8-HdL	°C/°F
V8	V8-LS2	Minimum value that can be set for Setpoint 2	37131	0	38945	192	RW	Word	Y	V8-LdL...V8-HS2	°C/°F
V8	V8-HC1	Setpoint 1 operating mode (Heating/Cooling)	37126	0	38945	768	RW	Word		0...1	num

Application 8 parameters											
V8	V8-HC2	Setpoint 2 operating mode (Heating/Cooling)	37127	0	38945	3072	RW	Word		0...1	num
V8	V8-Cit	Minimum compressor output activation time	37136	0	38945	49152	RW	Word		0...250	min
V8	V8-CAt	Maximum compressor output activation time	37137	0	38946	3	RW	Word		0...250	min
V8	V8-Ont	Compressor output ON time if regulation probe is faulty	37142	0	38946	12	RW	Word		0...250	min
V8	V8-OFt	Compressor output OFF time if regulation probe is faulty	37143	0	38946	48	RW	Word		0...250	min
V8	V8-dOn	Compressor output activation delay from call	37138	0	38946	192	RW	Word		0...250	s
V8	V8-dOF	Compressor output activation delay from switch-off	37139	0	38946	768	RW	Word		0...250	min
V8	V8-dbi	Delay between two consecutive compressor output power-ons	37140	0	38946	3072	RW	Word		0...250	min
V8	V8-OdO	Output activation delay at startup	37141	0	38946	12288	RW	Word		0...250	min
V8	V8-CFP	Condenser pre-ventilation time in Heat/Cool	37225	0	38947	12	RW	Word		0...255	s
V8	V8-CFd	Condenser fan cut-out during defrosting.	37226	0	38947	48	RW	Word		0...1	num
V8	V8-OF1	Remote offset	37147	0	38947	192	RW	Word	Y	-50.0...50.0	°C/°F
V8	V8-Pot	Pump down time	37253	0	38978	192	RW	Word		0...250	s
V8	V8-SS1	Compressor softstart: advance hotgas valve opening	37254	0	38978	768	RW	Word		0...250	s
V8	V8-SS2	Compressor softstart: delay hotgas valve closing	37255	0	38978	3072	RW	Word		0...250	s
V8	V8-dP1	Select defrost probe 1	37148	0	38947	768	RW	Word		0...8	num
V8	V8-dP2	Defrost probe 2 selection	37149	0	38947	3072	RW	Word		0...8	num
V8	V8-dtY	Type of defrost	37152	0	38947	12288	RW	Word		0...4	num
V8	V8-dFt	Dual evaporator defrost activation mode	37150	0	38947	49152	RW	Word		0...2	num
V8	V8-dit	Interval between defrosts	37153	0	38948	3	RW	Word		0...250	h/min/s
V8	V8-dt1	Unit of measure for defrost intervals	37156	0	38948	12	RW	Word		0...2	num
V8	V8-dt2	Unit of measure for defrost duration	37157	0	38948	48	RW	Word		0...2	num
V8	V8-dCt	Defrost interval count mode	37151	0	38948	192	RW	Word		0...5	num
V8	V8-dOH	Defrost cycle activation delay from the call	37158	0	38948	768	RW	Word		0...250	min
V8	V8-dE1	Evaporator 1 defrost maximum duration	37154	0	38948	3072	RW	Word		1...250	h/min/s
V8	V8-dE2	Evaporator 2 defrost maximum duration	37155	0	38948	12288	RW	Word		1...250	h/min/s

Application 8 parameters											
V8	V8-dS1	Evaporator 1 defrost end temperature	37160	0	38948	49152	RW	Word	Y	-58.0...302.0	°C/°F
V8	V8-dS2	Evaporator 2 defrost end temperature	37161	0	38949	3	RW	Word	Y	-58.0...302.0	°C/°F
V8	V8-dSS	Temperature threshold for starting defrost	37159	0	38949	12	RW	Word	Y	-58.0...302.0	°C/°F
V8	V8-dPO	Defrost activation request at power-on	37162	0	38949	48	RW	Word		0...1	num
V8	V8-tcd	Compressor output activation/deactivation time before a defrost	37163	0	38949	192	RW	Word	Y	-60...60	min
V8	V8-ndE	minimum defrost duration time	37164	0	38949	768	RW	Word		0...250	h/min/s
V8	V8-PdC	Hot gas extraction time at the end of the defrost	37165	0	38949	3072	RW	Word		0...250	min
V8	V8-tPd	Pump down time before defrost start	37167	0	38949	12288	RW	Word		0...255	min
V8	V8-dPH	Regular defrost start hour	37106	0	38949	49152	RW	Word		0...24	h
V8	V8-dPn	Regular defrost start minutes	37107	0	38950	3	RW	Word		0...59	min
V8	V8-dPd	Regular defrost interval duration	37108	0	38950	12	RW	Word		1...7	day
V8	V8-Fd1	1st weekend/holiday day	37055	0	38950	48	RW	Word		0...7	num
V8	V8-Fd2	2nd weekend/holiday day	37056	0	38950	192	RW	Word		0...7	num
V8	V8-Edt	Timeout and defrost end temperature specific to each event	37057	0	38950	768	RW	Word		0...1	num
V8	V8-PrH	Basin heater pre-activation time	37262	0	38979	3072	RW	Word		0...255	min
V8	V8-Fdn	Weekday defrost number	37005	0	38984	3	RW	Word		0...250	num
V8	V8-FFn	Weekend/holiday defrost number	37006	0	38984	12	RW	Word		0...250	num
V8	V8-d1H	Weekday defrost no. 1 start hour	37058	0	38950	3072	RW	Word		0...24	h
V8	V8-d1n	Weekday defrost no. 1 start minute	37059	0	38950	12288	RW	Word		0...59	min
V8	V8-d1t	1st weekday defrost duration	37060	0	38950	49152	RW	Word		0...250	min
V8	V8-d1S	1st weekday defrost end temperature	37061	0	38951	3	RW	Word	Y	-58.0...302.0	°C/°F
V8	V8-d2H	Weekday defrost no. 2 start hour	37062	0	38951	12	RW	Word		V8-d1H...24	h
V8	V8-d2n	Weekday defrost no. 2 start minutes	37063	0	38951	48	RW	Word		0...59	min
V8	V8-d2t	2nd weekday defrost duration	37064	0	38951	192	RW	Word		0...250	min
V8	V8-d2S	2nd weekday defrost end temperature	37065	0	38951	768	RW	Word	Y	-58.0...302.0	°C/°F
V8	V8-d3H	Weekday defrost no. 3 start hour	37066	0	38951	3072	RW	Word		V8-d2H...24	h
V8	V8-d3n	Weekday defrost no. 3 start minutes	37067	0	38951	12288	RW	Word		0...59	min
V8	V8-d3t	3rd weekday defrost duration	37068	0	38951	49152	RW	Word		0...250	min

Application 8 parameters											
V8	V8-d3S	3rd weekday defrost end temperature	37069	0	38952	3	RW	Word	Y	-58.0...302.0	°C/°F
V8	V8-d4H	Weekday defrost no. 4 start hour	37070	0	38952	12	RW	Word		V8-d3H...24	h
V8	V8-d4n	Weekday defrost no. 4 start minutes	37071	0	38952	48	RW	Word		0...59	min
V8	V8-d4t	4th weekday defrost duration	37072	0	38952	192	RW	Word		0...250	min
V8	V8-d4S	4th weekday defrost end temperature	37073	0	38952	768	RW	Word	Y	-58.0...302.0	°C/°F
V8	V8-d5H	Weekday defrost no. 5 start hour	37074	0	38952	3072	RW	Word		V8-d4H...24	h
V8	V8-d5n	Weekday defrost no. 5 start minutes	37075	0	38952	12288	RW	Word		0...59	min
V8	V8-d5t	5th weekday defrost duration	37076	0	38952	49152	RW	Word		0...250	min
V8	V8-d5S	5th weekday defrost end temperature	37077	0	38953	3	RW	Word	Y	-58.0...302.0	°C/°F
V8	V8-d6H	Weekday defrost no. 6 start hour	37078	0	38953	12	RW	Word		V8-d5H...24	h
V8	V8-d6n	Weekday defrost no. 6 start minutes	37079	0	38953	48	RW	Word		0...59	min
V8	V8-d6t	6th weekday defrost duration	37080	0	38953	192	RW	Word		0...250	min
V8	V8-d6S	6th weekday defrost end temperature	37081	0	38953	768	RW	Word	Y	-58.0...302.0	°C/°F
V8	V8-F1H	Weekend/holiday defrost no. 1 start hour	37082	0	38953	3072	RW	Word		0...24	h
V8	V8-F1n	Weekend/holiday defrost no. 1 start minute	37083	0	38953	12288	RW	Word		0...59	min
V8	V8-F1t	1st weekend/holiday defrost duration	37084	0	38953	49152	RW	Word		0...250	min
V8	V8-F1S	1st weekend/holiday defrost end temperature	37085	0	38954	3	RW	Word	Y	-58.0...302.0	°C/°F
V8	V8-F2H	Weekend/holiday defrost no. 2 start hour	37086	0	38954	12	RW	Word		V8-F1H...24	h
V8	V8-F2n	Weekend/holiday defrost no. 2 start minutes	37087	0	38954	48	RW	Word		0...59	min
V8	V8-F2t	2nd weekend/holiday defrost duration	37088	0	38954	192	RW	Word		0...250	min
V8	V8-F2S	2nd weekend/holiday defrost end temperature	37089	0	38954	768	RW	Word	Y	-58.0...302.0	°C/°F
V8	V8-F3H	Weekend/holiday defrost no. 3 start hour	37090	0	38954	3072	RW	Word		V8-F2H...24	h
V8	V8-F3n	Weekend/holiday defrost no. 3 start minutes	37091	0	38954	12288	RW	Word		0...59	min
V8	V8-F3t	3rd weekend/holiday defrost duration	37092	0	38954	49152	RW	Word		0...250	min
V8	V8-F3S	3rd weekend/holiday defrost end temperature	37093	0	38955	3	RW	Word	Y	-58.0...302.0	°C/°F
V8	V8-F4H	Weekend/holiday defrost no. 4 start hour	37094	0	38955	12	RW	Word		V8-F3H...24	h

Application 8 parameters											
V8	V8-F4n	Weekend/holiday defrost no. 4 start minutes	37095	0	38955	48	RW	Word		0...59	min
V8	V8-F4t	4th weekend/holiday defrost duration	37096	0	38955	192	RW	Word		0...250	min
V8	V8-F4S	4th weekend/holiday defrost end temperature	37097	0	38955	768	RW	Word	Y	-58.0...302.0	°C/°F
V8	V8-F5H	Weekend/holiday defrost no. 5 start hour	37098	0	38955	3072	RW	Word		V8-F4H...24	h
V8	V8-F5n	Weekend/holiday defrost no. 5 start minutes	37099	0	38955	12288	RW	Word		0...59	min
V8	V8-F5t	5th weekend/holiday defrost duration	37100	0	38955	49152	RW	Word		0...250	min
V8	V8-F5S	5th weekend/holiday defrost end temperature	37101	0	38956	3	RW	Word	Y	-58.0...302.0	°C/°F
V8	V8-F6H	Weekend/holiday defrost no. 6 start hour	37102	0	38956	12	RW	Word		V8-F5H...24	h
V8	V8-F6n	Weekend/holiday defrost no. 6 start minutes	37103	0	38956	48	RW	Word		0...59	min
V8	V8-F6t	6th weekend/holiday defrost duration	37104	0	38956	192	RW	Word		0...250	min
V8	V8-F6S	6th weekend/holiday defrost end temperature	37105	0	38956	768	RW	Word	Y	-58.0...302.0	°C/°F
V8	V8-FP1	Selection of evaporator fan probe in normal mode	37168	0	38956	3072	RW	Word		0...7	num
V8	V8-FP2	Selection of evaporator fan probe in defrost	37169	0	38956	12288	RW	Word		0...7	num
V8	V8-FPt	FSt parameter mode (absolute or relative)	37170	0	38956	49152	RW	Word		0...1	num
V8	V8-FSt	Evaporator fan disabling temperature	37171	0	38957	3	RW	Word	Y	-58.0...302.0	°C/°F
V8	V8-FAd	Evaporator fan trigger differential	37172	0	38957	12	RW	Word		.1...25.0	°C/°F
V8	V8-Fdt	Evaporator fan activation delay time after a defrost cycle	37173	0	38957	48	RW	Word		0...250	min
V8	V8-dt	Dripping time	37178	0	38957	192	RW	Word		0...250	min
V8	V8-dFd	Evaporator fan cut-out during defrost	37176	0	38957	768	RW	Word		0...1	num
V8	V8-FCO	Evaporator fan status with compressor output Off	37175	0	38957	3072	RW	Word		0...4	num
V8	V8-Fod	Evaporator fan status with door open	37177	0	38957	12288	RW	Word		0...1	num
V8	V8-FdC	Evaporator fan shutoff delay after compressor deactivation	37174	0	38957	49152	RW	Word		0...250	min
V8	V8-FOn	Evaporator fan On time in cyclical regulator mode	37179	0	38958	3	RW	Word		0...250	min
V8	V8-FOF	Evaporator fan Off time in cyclical regulator mode	37180	0	38958	12	RW	Word		0...250	min

Application 8 parameters											
V8	V8-Fnn	Evaporator fan ON time in night mode (duty cycle)	37181	0	38958	48	RW	Word		0...250	min
V8	V8-FnF	Evaporator fan OFF time in night mode (duty cycle)	37182	0	38958	192	RW	Word		0...250	min
V8	V8-FE1	Variable speed fan probe selection	37281	0	38982	48	RW	Word		0...12	num
V8	V8-FEt	Setpoint mode	37282	0	38982	192	RW	Word		0...1	num
V8	V8-FES	Setpoint	37283	0	38982	768	RW	Word	Y	-58...302	num
V8	V8-FEd	Band	37284	0	38982	3072	RW	Word		0.1...50	num
V8	V8-FEu	Cut-off band	37285	0	38982	12288	RW	Word		0...25	num
V8	V8-FEC	Cut-off differential	37286	0	38982	49152	RW	Word		0.1...25	num
V8	V8-FEr	Fan shutoff delay after compressor deactivation	37287	0	38983	3	RW	Word		0...250	min
V8	V8-FE2	Minimum day percentage	37288	0	38983	12	RW	Word		0...100	%
V8	V8-FE3	Maximum day percentage with compressor on	37289	0	38983	48	RW	Word		0...100	%
V8	V8-FE4	Maximum day percentage with compressor off	37290	0	38983	192	RW	Word		0...100	%
V8	V8-FE5	Minimum night percentage	37291	0	38983	768	RW	Word		0...100	%
V8	V8-FE6	Maximum night percentage with compressor on	37292	0	38983	3072	RW	Word		0...100	%
V8	V8-FE7	Maximum night percentage with compressor off	37293	0	38983	12288	RW	Word		0...100	%
V8	V8-FE8	Percentage during defrost	37294	0	38983	49152	RW	Word		0...100	%
V8	V8-FE9	Percentage in the event of probe error	37295	0	38995	12	RW	Word		0...100	%
V8	V8-FEA	Maximum pick-up speed	37296	0	38995	48	RW	Word		0...100	%
V8	V8-FEb	Fan pick-up time	37297	0	38995	192	RW	Word		0...250	s
V8	V8-FEP	Fan forcing period at pick-up speed	37298	0	38995	768	RW	Word		0...250	min
V8	V8-rA1	Temperature alarm probe 1 selection	37196	0	38958	768	RW	Word		0...7	num
V8	V8-rA2	Temperature alarm probe 2 selection	37197	0	38958	3072	RW	Word		0...7	num
V8	V8-Att	Alarm mode (absolute or relative)	37198	0	38958	12288	RW	Word		0...1	num
V8	V8-AFd	Alarm activation differential	37199	0	38958	49152	RW	Word		.1...25.0	°C/°F
V8	V8-HA1	Maximum alarm 1 threshold	37200	0	38959	3	RW	Word	Y	V8-LA1...302.0	°C/°F
V8	V8-LA1	Minimum alarm 1 threshold	37201	0	38959	12	RW	Word	Y	-58.0...V8-HA1	°C/°F
V8	V8-HA2	Maximum alarm 2 threshold	37202	0	38959	48	RW	Word	Y	V8-LA2...302.0	°C/°F
V8	V8-LA2	Minimum alarm 2 threshold	37203	0	38959	192	RW	Word	Y	-58.0...V8-HA2	°C/°F
V8	V8-PAO	Temperature alarm exclusion time from power-on	37204	0	38959	768	RW	Word		0...10	h

Application 8 parameters											
V8	V8-dAO	Exclusion time for temperature alarms after a defrost cycle	37206	0	38959	3072	RW	Word		0...250	min
V8	V8-OAO	High and low temperature alarms exclusion time after closing the door	37205	0	38959	12288	RW	Word		0...10	h
V8	V8-tdO	Door open alarm exclusion time	37250	0	38959	49152	RW	Word		0...250	num
V8	V8-tA1	Probe 1 High/Minimum Alarm Delay	37207	0	38960	3	RW	Word		0...250	min
V8	V8-tA2	Probe 2 High/Minimum Alarm Delay	37208	0	38960	12	RW	Word		0...250	min
V8	V8-dAt	Defrost ended due to timeout alarm signaling	37166	0	38960	48	RW	Word		0...1	num
V8	V8-EAL	Regulators inhibited by external alarm	37210	0	38960	192	RW	Word		0...2	num
V8	V8-rA3	Leak detection probe selection	37269	0	38980	12288	RW	Word		0...8	num
V8	V8-ALL	Low threshold leak alarm	37270	0	38980	49152	RW	Word		0...V8-ALH	num
V8	V8-ALH	High threshold leak alarm	37271	0	38981	3	RW	Word		V8-ALL...100	num
V8	V8-dAL	Alarm leak differential	37272	0	38981	12	RW	Word		0.1...100	num
V8	V8-AL1	Time probe remains above the low threshold due to leak alarm activation	37273	0	38981	48	RW	Word		0...250	min
V8	V8-AL2	Time probe remains above the high threshold due to leak alarm activation	37280	0	38982	12	RW	Word		0...250	min
V8	V8-tP	Enables alarm acknowledgment with any key	37251	0	38960	768	RW	Word		0...1	num
V8	V8-Art	Regular watchdog alarm activation period	37195	0	38960	3072	RW	Word		0...250	min*10
V8	V8-dSd	Enable light relay from door switch	37192	0	38960	12288	RW	Word		0...1	num
V8	V8-dLt	Light relay off delay from door closure	37193	0	38960	49152	RW	Word		0...250	min
V8	V8-OFL	Enable cold room lights off via key during the delay set in parameter dLt	37194	0	38961	3	RW	Word		0...1	num
V8	V8-dOd	Enable utility shutoff upon door switch activation	37209	0	38961	12	RW	Word		0...3	num
V8	V8-dOA	Behavior forced by digital input	37211	0	38961	48	RW	Word		0...5	num
V8	V8-PEA	Enable forced behavior from door switch and/or external alarm.	37212	0	38961	192	RW	Word		0...3	num
V8	V8-dCO	Compressor activation delay from acknowledgment	37213	0	38961	768	RW	Word		0...250	min
V8	V8-dFO	Fan enabling delay from acknowledgment	37214	0	38961	3072	RW	Word		0...250	min

Application 8 parameters											
V8	V8-ASb	Instrument off active light/auxiliary digital input or key	37240	0	38961	12288	RW	Word		0...1	num
V8	V8-L00	Shared probe	36992	0	38961	49152	RW	Word		0...7	num
V8	V8-L01	Distributed viewing (refers to slave)	36993	0	38962	3	RW	Word		0...2	num
V8	V8-L02	Setpoint synchronization	36994	0	38962	12	RW	Word		0...1	num
V8	V8-L03	Defrost synchronization	36995	0	38962	48	RW	Word		0...2	num
V8	V8-L04	Inhibit resources at the end of defrost	36996	0	38962	192	RW	Word		0...1	num
V8	V8-L05	Stand-by synchronization	36997	0	38962	768	RW	Word		0...1	num
V8	V8-L06	Lights synchronization	36998	0	38962	3072	RW	Word		0...1	num
V8	V8-L07	Reduced set synchronization	36999	0	38962	12288	RW	Word		0...1	num
V8	V8-L08	AUX synchronization	37000	0	38962	49152	RW	Word		0...1	num
V8	V8-L09	Shared saturation probe	37001	0	38963	3	RW	Word		0...1	num
V8	V8-L10	Resource unlocking timeout during synchronized defrosts	37252	0	38963	12	RW	Word		0...250	min
V8	V8-L11	Number of devices connected in Link2	37002	0	38980	48	RW	Word		0...8	num
V8	V8-L12	Alarm relay sharing in Link2	37003	0	38980	192	RW	Word		0...2	num
V8	V8-L13	Link2 serial frame configuration	37263	0	38979	12288	RW	Word		0...2	num
V8	V8-L14	Force cool mode	37279	0	38982	3	RW	Word		0...1	num
V8	V8-dcS	Deep cooling setpoint	37186	0	38963	768	RW	Word	Y	-58.0...302.0	°C/°F
V8	V8-tdc	Deep cooling duration	37187	0	38963	3072	RW	Word		0...250	min
V8	V8-dcc	Defrost delay after deep cooling	37188	0	38963	12288	RW	Word		0...250	min
V8	V8-ESt	Type of action for the Energy Saving function	37115	0	38963	49152	RW	Word		0...8	num
V8	V8-ESF	Night mode activation (Energy Saving)	37183	0	38964	3	RW	Word		0...1	num
V8	V8-Cdt	Door closing time	37184	0	38964	12	RW	Word		0...255	min*10
V8	V8-ESo	Low consumption mode disabling timeout (door switch)	37185	0	38964	48	RW	Word		0...10	num
V8	V8-OS1	Offset on setpoint 1	37132	0	38964	192	RW	Word	Y	-50.0...50.0	°C/°F
V8	V8-OS2	Offset on setpoint 2	37133	0	38964	768	RW	Word	Y	-50.0...50.0	°C/°F
V8	V8-Od1	Refrigerated cabinets energy saving offset 1	37134	0	38964	3072	RW	Word	Y	-50.0...50.0	°C/°F
V8	V8-Od2	Refrigerated cabinets energy saving offset 2	37135	0	38964	12288	RW	Word	Y	-50.0...50.0	°C/°F
V8	V8-dn1	Differential during energy saving mode 1	37123	0	38964	49152	RW	Word	Y	-58.0...302.0	°C/°F
V8	V8-dn2	Differential during energy saving mode 2	37124	0	38965	3	RW	Word	Y	-58.0...302.0	°C/°F
V8	V8-EdH	Weekday energy saving start hour	37109	0	38965	12	RW	Word		0...24	h
V8	V8-Edn	Weekday energy saving start minutes	37110	0	38965	48	RW	Word		0...59	min
V8	V8-Edd	Weekday energy saving duration	37111	0	38965	192	RW	Word		1...72	h

Application 8 parameters											
V8	V8-EFH	Weekend/holiday energy saving start hour	37112	0	38965	768	RW	Word		0...24	h
V8	V8-EFn	Weekend/holiday energy saving start minutes	37113	0	38965	3072	RW	Word		0...59	min
V8	V8-EFd	Weekend/holiday energy saving duration	37114	0	38965	12288	RW	Word		1...72	h
V8	V8-FH	Frame heater probe selection	37215	0	38965	49152	RW	Word		0...9	num
V8	V8-FHt	Frame heater period	37217	0	38966	3	RW	Word		1...2500	s
V8	V8-FH0	Frame heater set	37218	0	38966	12	RW	Word	Y	-58.0...302.0	°C/°F
V8	V8-FH1	Frame heater offset	37219	0	38966	48	RW	Word		0...25.0	°C/°F
V8	V8-FH2	Frame heater band	37220	0	38966	192	RW	Word	Y	-58.0...302.0	°C/°F
V8	V8-FH3	Frame heater minimum percentage/duty-cycle	37221	0	38966	768	RW	Word		0...100	%
V8	V8-FH4	Frame heater maximum percentage/day duty-cycle	37222	0	38966	3072	RW	Word		0...100	%
V8	V8-FH5	Frame heater maximum percentage/night duty-cycle	37223	0	38966	12288	RW	Word		0...100	%
V8	V8-FH6	Frame heater percentage/duty-cycle in defrost	37224	0	38966	49152	RW	Word		0...100	%
V8	V8-LOC	Disable terminal	37227	0	38967	3	RW	Word		0...1	num
V8	V8-PS1	Password 1 value	37228	0	38967	12	RW	Word		0...250	num
V8	V8-PS2	Password 2 value	37229	0	38967	48	RW	Word		0...250	num
V8	V8-ndt	Display with decimal point	37230	0	38967	192	RW	Word		0...1	num
V8	V8-CA1	Analog input 1 calibration	37036	0	38967	768	RW	Word	Y	-30.0...30.0	°C/°F
V8	V8-CA2	Analog input 2 calibration	37037	0	38967	3072	RW	Word	Y	-30.0...30.0	°C/°F
V8	V8-CA3	Analog input 3 calibration	37038	0	38967	12288	RW	Word	Y	-30.0...30.0	°C/°F
V8	V8-CA4	Analog input 4 calibration	37039	0	38967	49152	RW	Word	Y	-30.0...30.0	°C/°F
V8	V8-CA5	Analog input 5 calibration	37040	0	38968	3	RW	Word	Y	-30.0...30.0	°C/°F
V8	V8-CA6	Analog input 6 calibration	37041	0	38968	12	RW	Word	Y	-30...30	bar/psi
V8	V8-CA7	Analog input 7 calibration	37042	0	38968	48	RW	Word	Y	-30...30	bar/psi
V8	V8-LdL	Minimum display value	37231	0	38968	192	RW	Word	Y	-58.0...V8-HdL	°C/°F
V8	V8-HdL	Maximum display value	37232	0	38968	768	RW	Word	Y	V8-LdL...302.0	°C/°F
V8	V8-ddL	Display lock mode during a defrost	37233	0	38968	3072	RW	Word		0...2	num
V8	V8-Ldd	Display lock timeout from end of defrost	37234	0	38968	12288	RW	Word		0...250	min
V8	V8-dro	Select °C / °F	37235	0	38968	49152	RW	Word		0...1	num
V8	V8-SbP	Pressure unit of measure	37236	0	38969	3	RW	Word		0...1	num

Application 8 parameters											
V8	V8-ddd	Select main display value	37237	0	38969	12	RW	Word		0...8	num
V8	V8-ddE	Resource displayed on ECHO	37238	0	38969	48	RW	Word		0...9	num
V8	V8-rPH	Receiver maximum valve opening %	37189	0	38969	192	RW	Word		0...5	num
V8	V8-H00	Select analog input type NTC/PTC	37004	0	38969	768	RW	Word		0...2	num
V8	V8-H02	Function activation time from terminal	37239	0	38969	3072	RW	Word		0...250	s
V8	V8-H08	Stand-by operating mode	37241	0	38969	12288	RW	Word		0...2	num
V8	V8-H11	Digital input 1 configurability and polarity	37007	0	38969	49152	RW	Word	Y	-18...18	num
V8	V8-H12	Digital input 2 configurability and polarity	37008	0	38970	3	RW	Word	Y	-18...18	num
V8	V8-H13	Digital input 3 configurability and polarity	37009	0	38970	12	RW	Word	Y	-18...18	num
V8	V8-H14	Digital input 4 configurability and polarity	37010	0	38970	48	RW	Word	Y	-18...18	num
V8	V8-H15	Digital input 5 configurability and polarity	37011	0	38970	192	RW	Word	Y	-18...18	num
V8	V8-H16	Digital input 6 configurability and polarity	37012	0	38970	768	RW	Word	Y	-18...18	num
V8	V8-H17	Digital input 7 configurability and polarity	37013	0	38970	3072	RW	Word	Y	-18...18	num
V8	V8-H18	Digital input 8 configurability and polarity	37014	0	38970	12288	RW	Word	Y	-18...18	num
V8	V8-i01	Digital input 9 configurability and polarity	37274	0	38981	192	RW	Word	Y	-18...18	num
V8	V8-i02	Digital input 10 configurability and polarity	37275	0	38981	768	RW	Word	Y	-18...18	num
V8	V8-dti	Digital inputs 1 and 2 delay unit of measure	37023	0	38970	49152	RW	Word		0...1	num
V8	V8-d11	D.I. 1 activation indication delay time	37015	0	38971	3	RW	Word		0...255	min/s
V8	V8-d12	D.I. 2 activation indication delay time	37016	0	38971	12	RW	Word		0...255	min/s
V8	V8-d13	D.I. 3 activation indication delay time	37017	0	38971	48	RW	Word		0...255	min
V8	V8-d14	D.I. 4 activation indication delay time	37018	0	38971	192	RW	Word		0...255	min
V8	V8-d15	D.I. 5 activation indication delay time	37019	0	38971	768	RW	Word		0...255	min
V8	V8-d16	D.I. 6 activation indication delay time	37020	0	38971	3072	RW	Word		0...255	min
V8	V8-d17	D.I. 7 activation indication delay time	37021	0	38971	12288	RW	Word		0...255	min
V8	V8-d18	D.I. 8 activation indication delay time	37022	0	38971	49152	RW	Word		0...255	min
V8	V8-01i	D.I. 9 activation indication delay time	37276	0	38981	3072	RW	Word		0...255	min/s

Application 8 parameters											
V8	V8-02i	D.I. 10 activation indication delay time	37277	0	38981	12288	RW	Word		0...255	min
V8	V8-H21	Configurability of digital output 1	37044	0	38972	3	RW	Word		0...19	num
V8	V8-H22	Configurability of digital output 2	37045	0	38972	12	RW	Word		0...19	num
V8	V8-H23	Configurability of digital output 3	37046	0	38972	48	RW	Word		0...19	num
V8	V8-H24	Configurability of digital output 4	37047	0	38972	192	RW	Word		0...19	num
V8	V8-H25	Configurability of digital output 5	37048	0	38972	768	RW	Word		0...19	num
V8	V8-H27	Configurability of digital output 7	37050	0	38972	12288	RW	Word		0...19	num
V8	V8-H29	Enable buzzer	37051	0	38972	49152	RW	Word		0...1	num
V8	V8-d01	Configurability of digital output 8	37267	0	38980	768	RW	Word		0...19	num
V8	V8-d02	Configurability of digital output 9	37268	0	38980	3072	RW	Word		0...19	num
V8	V8-H31	Configurability of the UP key	37242	0	38973	3	RW	Word		0...9	num
V8	V8-H32	Configurability of the DOWN key	37243	0	38973	12	RW	Word		0...9	num
V8	V8-H33	Configurability of the ESC key	37244	0	38973	48	RW	Word		0...9	num
V8	V8-H34	Configurability of the Free 1 key	37245	0	38973	192	RW	Word		0...9	num
V8	V8-H35	Configurability of the Free 2 key	37246	0	38973	768	RW	Word		0...9	num
V8	V8-H36	Configurability of the Free 3 key	37247	0	38973	3072	RW	Word		0...9	num
V8	V8-H37	Configurability of the Free 4 key	37248	0	38973	12288	RW	Word		0...9	num
V8	V8-H41	Analog input 1 calibration	37024	0	38973	49152	RW	Word		0...2	num
V8	V8-H42	Analog input 2 calibration	37025	0	38974	3	RW	Word		0...2	num
V8	V8-H43	Analog input 3 calibration	37026	0	38974	12	RW	Word		0...2	num
V8	V8-H44	Analog input 4 calibration	37027	0	38974	48	RW	Word		0...2	num
V8	V8-H45	Analog input 5 calibration	37028	0	38974	192	RW	Word		0...2	num
V8	V8-H46	Analog input 6 calibration	37029	0	38974	768	RW	Word		0...2	num
V8	V8-H47	Analog input 7 calibration	37030	0	38974	3072	RW	Word		0...2	num
V8	V8-H48	Analog input 8 calibration	37278	0	38981	49152	RW	Word		0...2	num
V8	V8-H50	Configurability of analog output 1	37052	0	38974	12288	RW	Word		0...1	num
V8	V8-H51	Function associated with analog output	37053	0	38974	49152	RW	Word		0...3	num
V8	V8-H68	RTC present	37054	0	38975	3	RW	Word		0...1	num
V8	V8-H70	Selection of 1st sensor for virtual probe	37032	0	38975	12	RW	Word		0...5	num
V8	V8-H71	Selection of 2nd sensor for virtual probe	37033	0	38975	48	RW	Word		0...5	num

Application 8 parameters											
V8	V8-H72	Day virtual probe calculation %	37034	0	38975	192	RW	Word		0...100	%
V8	V8-H73	Night virtual probe calculation %	37035	0	38975	768	RW	Word		0...100	%
V8	V8-H74	Selection of 1st sensor for filtered virtual probe	37264	0	38979	49152	RW	Word		0...65635	num
V8	V8-H75	Percentage in thousandths of the incoming signal for filtered virtual probe	37265	0	38980	3	RW	Word		0...65635	num
V8	V8-H76	Filtered virtual probe offset	37266	0	38980	12	RW	Word		0...65635	num
V8	V8-EtY	Selection of electronic expansion valve driver	37249	0	38975	3072	RW	Word		0...2	num
V8	V8-OHP	Selection of oil temperature probe	37256	0	38978	12288	RW	Word		0...8	num
V8	V8-OSP	Oil heater setpoint	37257	0	38978	49152	RW	Word	Y	V8-OLS...V8-OHS	°C/°F
V8	V8-OHd	Oil heater differential	37258	0	38979	3	RW	Word		.1...25.0	°C/°F
V8	V8-OHS	Maximum oil heater setpoint value that can be set	37260	0	38979	48	RW	Word	Y	V8-OLS...302.0	°C/°F
V8	V8-OLS	Minimum oil heater setpoint value that can be set	37261	0	38979	192	RW	Word	Y	-58.0...V8-OHS	°C/°F
V8	UL	Visibility of parameter transfer function (Device -> UNICARD/MFK)	-	-	38978	3	RW	Word		0...3	num
V8	dL	Visibility of parameter transfer function (UNICARD/MFK -> Device)	-	-	38978	12	RW	Word		0...3	num
V8	Fr	Visibility of UNICARD/MFK formatting function	-	-	38978	48	RW	Word		0...3	num

Folder Visibility Table

Label	Address	Filter	Description	Data size	Range	MU
Visibility of folders for loaded application						
CP	38175	12288	Visibility of folder CP (compressor)	Word	0...3	num
dEF	38175	49152	Visibility of folder dEF (defrost)	Word	0...3	num
FAn	38176	3	Visibility of folder FAn (fans)	Word	0...3	num
FE	38179	12	Visibility of folder FE (modulated fans)	Word	0...3	num
AL	38176	12	Visibility of folder AL (alarms)	Word	0...3	num
Lit	38176	48	Visibility of folder Lit (lights and digital inputs)	Word	0...3	num
Lin	38176	192	Visibility of folder Lin (link ²)	Word	0...3	num
dEC	38176	12288	Visibility of folder dEC (Deep Cooling Cycle)	Word	0...3	num
EnS	38176	49152	Visibility of folder EnS (energy saving)	Word	0...3	num
FrH	38177	3	Visibility of folder FrH (anti-condensation heaters)	Word	0...3	num
Add	38177	12	Visibility of folder Add (communication)	Word	0...3	num
diS	38177	48	Visibility of folder diS (display)	Word	0...3	num
HCP	38177	192	Visibility of folder HCP (HACCP)	Word	0...3	num
CnF	38177	768	Visibility of folder CnF (configuration)	Word	0...3	num
EE0	38177	3072	Visibility of folder EE0 (Electronic Expansion Valve)	Word	0...3	num
FPr	38177	12288	Visibility of folder FPr (CopyCard)	Word	0...3	num
FnC	38177	49152	Visibility of folder FnC (functions)	Word	0...3	num
OiL	38179	768	Visibility of folder OiL (Compressor oil heater)	Word	0...3	num
Visibility of folders for AP1 application						
V1-CP	38303	12288	Visibility of folder CP (compressor)	Word	0...3	num
V1-dEF	38303	49152	Visibility of folder dEF (defrost)	Word	0...3	num
V1-FAn	38304	3	Visibility of folder FAn (fans)	Word	0...3	num
V1-FE	38307	12	Visibility of folder FE (modulated fans)	Word	0...3	num
V1-AL	38304	12	Visibility of folder AL (alarms)	Word	0...3	num
V1-Lit	38304	48	Visibility of folder Lit (lights and digital inputs)	Word	0...3	num
V1-Lin	38304	192	Visibility of folder Lin (link ²)	Word	0...3	num
V1-dEC	38304	12288	Visibility of folder dEC (Deep Cooling Cycle)	Word	0...3	num
V1-EnS	38304	49152	Visibility of folder EnS (energy saving)	Word	0...3	num
V1-FrH	38305	3	Visibility of folder FrH (anti-condensation heaters)	Word	0...3	num
V1-Add	38305	12	Visibility of folder Add (communication)	Word	0...3	num
V1-diS	38305	48	Visibility of folder diS (display)	Word	0...3	num
V1-HCP	38305	192	Visibility of folder HCP (HACCP)	Word	0...3	num
V1-CnF	38305	768	Visibility of folder CnF (configuration)	Word	0...3	num
V1-EE0	38305	3072	Visibility of folder EE0 (Electronic Expansion Valve)	Word	0...3	num
V1-FPr	38305	12288	Visibility of folder FPr (CopyCard)	Word	0...3	num
V1-FnC	38305	49152	Visibility of folder FnC (functions)	Word	0...3	num
V1-OiL	38307	768	Visibility of folder OiL (Compressor oil heater)	Word	0...3	num
Visibility of folders for AP2 application						
V2-CP	38399	12288	Visibility of folder CP (compressor)	Word	0...3	num
V2-dEF	38399	49152	Visibility of folder dEF (defrost)	Word	0...3	num
V2-FAn	38400	3	Visibility of folder FAn (fans)	Word	0...3	num
V2-FE	38403	12	Visibility of folder FE (modulated fans)	Word	0...3	num
V2-AL	38400	12	Visibility of folder AL (alarms)	Word	0...3	num
V2-Lit	38400	48	Visibility of folder Lit (lights and digital inputs)	Word	0...3	num
V2-Lin	38400	192	Visibility of folder Lin (link ²)	Word	0...3	num
V2-dEC	38400	12288	Visibility of folder dEC (Deep Cooling Cycle)	Word	0...3	num
V2-EnS	38400	49152	Visibility of folder EnS (energy saving)	Word	0...3	num
V2-FrH	38401	3	Visibility of folder FrH (anti-condensation heaters)	Word	0...3	num

Label	Address	Filter	Description	Data size	Range	MU
V2-Add	38401	12	Visibility of folder Add (communication)	Word	0...3	num
V2-diS	38401	48	Visibility of folder diS (display)	Word	0...3	num
V2-HCP	38401	192	Visibility of folder HCP (HACCP)	Word	0...3	num
V2-CnF	38401	768	Visibility of folder CnF (configuration)	Word	0...3	num
V2-EE0	38401	3072	Visibility of folder EE0 (Electronic Expansion Valve)	Word	0...3	num
V2-FPr	38401	12288	Visibility of folder FPr (CopyCard)	Word	0...3	num
V2-FnC	38401	49152	Visibility of folder FnC (functions)	Word	0...3	num
V2-OiL	38403	768	Visibility of folder OiL (Compressor oil heater)	Word	0...3	num
Visibility of folders for AP3 application						
V3-CP	38495	12288	Visibility of folder CP (compressor)	Word	0...3	num
V3-dEF	38495	49152	Visibility of folder dEF (defrost)	Word	0...3	num
V3-FAn	38496	3	Visibility of folder FAn (fans)	Word	0...3	num
V3-FE	38499	12	Visibility of folder FE (modulated fans)	Word	0...3	num
V3-AL	38496	12	Visibility of folder AL (alarms)	Word	0...3	num
V3-Lit	38496	48	Visibility of folder Lit (lights and digital inputs)	Word	0...3	num
V3-Lin	38496	192	Visibility of folder Lin (link ²)	Word	0...3	num
V3-dEC	38496	12288	Visibility of folder dEC (Deep Cooling Cycle)	Word	0...3	num
V3-EnS	38496	49152	Visibility of folder EnS (energy saving)	Word	0...3	num
V3-FrH	38497	3	Visibility of folder FrH (anti-condensation heaters)	Word	0...3	num
V3-Add	38497	12	Visibility of folder Add (communication)	Word	0...3	num
V3-diS	38497	48	Visibility of folder diS (display)	Word	0...3	num
V3-HCP	38497	192	Visibility of folder HCP (HACCP)	Word	0...3	num
V3-CnF	38497	768	Visibility of folder CnF (configuration)	Word	0...3	num
V3-EE0	38497	3072	Visibility of folder EE0 (Electronic Expansion Valve)	Word	0...3	num
V3-FPr	38497	12288	Visibility of folder FPr (CopyCard)	Word	0...3	num
V3-FnC	38497	49152	Visibility of folder FnC (functions)	Word	0...3	num
V3-OiL	38499	768	Visibility of folder OiL (Compressor oil heater)	Word	0...3	num
Visibility of folders for AP4 application						
V4-CP	38591	12288	Visibility of folder CP (compressor)	Word	0...3	num
V4-dEF	38591	49152	Visibility of folder dEF (defrost)	Word	0...3	num
V4-FAn	38592	3	Visibility of folder FAn (fans)	Word	0...3	num
V4-FE	38595	12	Visibility of folder FE (modulated fans)	Word	0...3	num
V4-AL	38592	12	Visibility of folder AL (alarms)	Word	0...3	num
V4-Lit	38592	48	Visibility of folder Lit (lights and digital inputs)	Word	0...3	num
V4-Lin	38592	192	Visibility of folder Lin (link ²)	Word	0...3	num
V4-dEC	38592	12288	Visibility of folder dEC (Deep Cooling Cycle)	Word	0...3	num
V4-EnS	38592	49152	Visibility of folder EnS (energy saving)	Word	0...3	num
V4-FrH	38593	3	Visibility of folder FrH (anti-condensation heaters)	Word	0...3	num
V4-Add	38593	12	Visibility of folder Add (communication)	Word	0...3	num
V4-diS	38593	48	Visibility of folder diS (display)	Word	0...3	num
V4-HCP	38593	192	Visibility of folder HCP (HACCP)	Word	0...3	num
V4-CnF	38593	768	Visibility of folder CnF (configuration)	Word	0...3	num
V4-EE0	38593	3072	Visibility of folder EE0 (Electronic Expansion Valve)	Word	0...3	num
V4-FPr	38593	12288	Visibility of folder FPr (CopyCard)	Word	0...3	num
V4-FnC	38593	49152	Visibility of folder FnC (functions)	Word	0...3	num
V4-OiL	38595	768	Visibility of folder OiL (Compressor oil heater)	Word	0...3	num
Visibility of folders for AP5 application						
V5-CP	38687	12288	Visibility of folder CP (compressor)	Word	0...3	num
V5-dEF	38687	49152	Visibility of folder dEF (defrost)	Word	0...3	num
V5-FAn	38688	3	Visibility of folder FAn (fans)	Word	0...3	num
V5-FE	38691	12	Visibility of folder FE (modulated fans)	Word	0...3	num

Label	Address	Filter	Description	Data size	Range	MU
V5-AL	38688	12	Visibility of folder AL (alarms)	Word	0...3	num
V5-Lit	38688	48	Visibility of folder Lit (lights and digital inputs)	Word	0...3	num
V5-Lin	38688	192	Visibility of folder Lin (link ²)	Word	0...3	num
V5-dEC	38688	12288	Visibility of folder dEC (Deep Cooling Cycle)	Word	0...3	num
V5-EnS	38688	49152	Visibility of folder EnS (energy saving)	Word	0...3	num
V5-FrH	38689	3	Visibility of folder FrH (anti-condensation heaters)	Word	0...3	num
V5-Add	38689	12	Visibility of folder Add (communication)	Word	0...3	num
V5-diS	38689	48	Visibility of folder diS (display)	Word	0...3	num
V5-HCP	38689	192	Visibility of folder HCP (HACCP)	Word	0...3	num
V5-CnF	38689	768	Visibility of folder CnF (configuration)	Word	0...3	num
V5-EE0	38689	3072	Visibility of folder EE0 (Electronic Expansion Valve)	Word	0...3	num
V5-FPr	38689	12288	Visibility of folder FPr (CopyCard)	Word	0...3	num
V5-FnC	38689	49152	Visibility of folder FnC (functions)	Word	0...3	num
V5-OiL	38691	768	Visibility of folder OiL (Compressor oil heater)	Word	0...3	num
Visibility of folders for AP6 application						
V6-CP	38783	12288	Visibility of folder CP (compressor)	Word	0...3	num
V6-dEF	38783	49152	Visibility of folder dEF (defrost)	Word	0...3	num
V6-FAn	38784	3	Visibility of folder FAn (fans)	Word	0...3	num
V6-FE	38787	12	Visibility of folder FE (modulated fans)	Word	0...3	num
V6-AL	38784	12	Visibility of folder AL (alarms)	Word	0...3	num
V6-Lit	38784	48	Visibility of folder Lit (lights and digital inputs)	Word	0...3	num
V6-Lin	38784	192	Visibility of folder Lin (link ²)	Word	0...3	num
V6-dEC	38784	12288	Visibility of folder dEC (Deep Cooling Cycle)	Word	0...3	num
V6-EnS	38784	49152	Visibility of folder EnS (energy saving)	Word	0...3	num
V6-FrH	38785	3	Visibility of folder FrH (anti-condensation heaters)	Word	0...3	num
V6-Add	38785	12	Visibility of folder Add (communication)	Word	0...3	num
V6-diS	38785	48	Visibility of folder diS (display)	Word	0...3	num
V6-HCP	38785	192	Visibility of folder HCP (HACCP)	Word	0...3	num
V6-CnF	38785	768	Visibility of folder CnF (configuration)	Word	0...3	num
V6-EE0	38785	3072	Visibility of folder EE0 (Electronic Expansion Valve)	Word	0...3	num
V6-FPr	38785	12288	Visibility of folder FPr (CopyCard)	Word	0...3	num
V6-FnC	38785	49152	Visibility of folder FnC (functions)	Word	0...3	num
V6-OiL	38787	768	Visibility of folder OiL (Compressor oil heater)	Word	0...3	num
Visibility of folders for AP7 application						
V7-CP	38879	12288	Visibility of folder CP (compressor)	Word	0...3	num
V7-dEF	38879	49152	Visibility of folder dEF (defrost)	Word	0...3	num
V7-FAn	38880	3	Visibility of folder FAn (fans)	Word	0...3	num
V7-FE	38883	12	Visibility of folder FE (modulated fans)	Word	0...3	num
V7-AL	38880	12	Visibility of folder AL (alarms)	Word	0...3	num
V7-Lit	38880	48	Visibility of folder Lit (lights and digital inputs)	Word	0...3	num
V7-Lin	38880	192	Visibility of folder Lin (link ²)	Word	0...3	num
V7-dEC	38880	12288	Visibility of folder dEC (Deep Cooling Cycle)	Word	0...3	num
V7-EnS	38880	49152	Visibility of folder EnS (energy saving)	Word	0...3	num
V7-FrH	38881	3	Visibility of folder FrH (anti-condensation heaters)	Word	0...3	num
V7-Add	38881	12	Visibility of folder Add (communication)	Word	0...3	num
V7-diS	38881	48	Visibility of folder diS (display)	Word	0...3	num
V7-HCP	38881	192	Visibility of folder HCP (HACCP)	Word	0...3	num
V7-CnF	38881	768	Visibility of folder CnF (configuration)	Word	0...3	num
V7-EE0	38881	3072	Visibility of folder EE0 (Electronic Expansion Valve)	Word	0...3	num
V7-FPr	38881	12288	Visibility of folder FPr (CopyCard)	Word	0...3	num
V7-FnC	38881	49152	Visibility of folder FnC (functions)	Word	0...3	num

Label	Address	Filter	Description	Data size	Range	MU
V7-OiL	38883	768	Visibility of folder OiL (Compressor oil heater)	Word	0...3	num
Visibility of folders for AP8 application						
V8-CP	38975	12288	Visibility of folder CP (compressor)	Word	0...3	num
V8-dEF	38975	49152	Visibility of folder dEF (defrost)	Word	0...3	num
V8-FAn	38976	3	Visibility of folder FAn (fans)	Word	0...3	num
V8-FE	38979	12	Visibility of folder FE (modulated fans)	Word	0...3	num
V8-AL	38976	12	Visibility of folder AL (alarms)	Word	0...3	num
V8-Lit	38976	48	Visibility of folder Lit (lights and digital inputs)	Word	0...3	num
V8-Lin	38976	192	Visibility of folder Lin (link ²)	Word	0...3	num
V8-dEC	38976	12288	Visibility of folder dEC (Deep Cooling Cycle)	Word	0...3	num
V8-EnS	38976	49152	Visibility of folder EnS (energy saving)	Word	0...3	num
V8-FrH	38977	3	Visibility of folder FrH (anti-condensation heaters)	Word	0...3	num
V8-Add	38977	12	Visibility of folder Add (communication)	Word	0...3	num
V8-diS	38977	48	Visibility of folder diS (display)	Word	0...3	num
V8-HCP	38977	192	Visibility of folder HCP (HACCP)	Word	0...3	num
V8-CnF	38977	768	Visibility of folder CnF (configuration)	Word	0...3	num
V8-EE0	38977	3072	Visibility of folder EE0 (Electronic Expansion Valve)	Word	0...3	num
V8-FPr	38977	12288	Visibility of folder FPr (CopyCard)	Word	0...3	num
V8-FnC	38977	49152	Visibility of folder FnC (functions)	Word	0...3	num
V8-OiL	38979	768	Visibility of folder OiL (Compressor oil heater)	Word	0...3	num

Table of Modbus Resources

Label	Description	Address	Filter	Type	Data_Size	CPL	Range	MU
A1	Regulation probe 1	6145	0	R	Word	Y	-67.0...320	°C/°F
A2	Regulation probe 2	6146	0	R	Word	Y	-67.0...320	°C/°F
A3	Temperature alarm probe 1	6147	0	R	Word	Y	-67.0...320	°C/°F
A4	Temperature alarm probe 2	6148	0	R	Word	Y	-67.0...320	°C/°F
A5	Defrost probe 1	6149	0	R	Word	Y	-67.0...320	°C/°F
A6	Defrost probe 2	6150	0	R	Word	Y	-67.0...320	°C/°F
A7	Evaporator fan probe	6151	0	R	Word	Y	-67.0...320	°C/°F
A8	Frame heater probe	6152	0	R	Word	Y	-67.0...320	°C/°F
A9	Valve 1 evaporator pressure	6153	0	R	Word	Y	-67.0...320	bar/Psi
A10	Valve 1 overheating temperature	6154	0	R	Word	Y	-67.0...320	°C/°F
A11	HACCP probe	6155	0	R	Word	Y	-67.0...320	°C/°F
SP1	Regulation setpoint 1 value	6156	0	R	Word	Y	-67.0...320	°C/°F
SP2	Regulation setpoint 2 value	6157	0	R	Word	Y	-67.0...320	°C/°F
OH1	Valve 1 overheating	6158	0	R	Word	Y	-67.0...320	°C/°F
BKP_bar	Backup saturation probe 1	6180	0	R	Word	Y	-6.7...32.0	bar
BKP_psi	Backup saturation probe 1	6180	0	R	Word	Y	-67...320	Psi
rDP	Remote dew point value 1	6173	0	R	Word	Y	-67.0...320	°C/°F
dis	Analog input (viewing) 1	6159	0	R	Word	Y	-67.0...320	°C/°F
vr1	Virtual probe 1	6160	0	R	Word	Y	-67.0...320	°C/°F
vr2	Virtual probe 2	6161	0	R	Word	Y	-67.0...320	°C/°F
EEV	Valve 1 opening percentage	6177	0	R	Word	N	0...100	%
FrH	Frame heater output	6176	0	R	Word	N	0...100	%
FE1	Modulated fan probe	6189	0	R	Word	Y	-67.0...320	°C/°F
FAn	Analog fan output 1	6188	0	R	Word	N	0...100	%
OIL	Temperature probe oil	6169	0	R	Word	Y	-67.0...320	°C/°F
LKD	Gas concentration	6170	0	R	Word	N	0...100	%
E1	Probe Pb1 error	6162	1	R	Word	N	0...1	flag
E2	Probe Pb2 error	6162	2	R	Word	N	0...1	flag
E3	Probe Pb3 error	6162	4	R	Word	N	0...1	flag
E4	Probe Pb4 error	6162	8	R	Word	N	0...1	flag
E5	Probe Pb5 error	6162	16	R	Word	N	0...1	flag
E6	Probe Pb6 error	6162	32	R	Word	N	0...1	flag
E7	Probe Pb7 error	6162	64	R	Word	N	0...1	flag
AL1	Regulator 1 low alarm	6162	8192	R	Word	N	0...1	flag
AH1	Regulator 1 high alarm	6162	16384	R	Word	N	0...1	flag
AL2	Regulator 2 low alarm	6162	32768	R	Word	N	0...1	flag
AH2	Regulator 2 high alarm	6163	1	R	Word	N	0...1	flag
OPd	Door open alarm	6163	2	R	Word	N	0...1	flag
EA	External alarm	6163	4	R	Word	N	0...1	flag
Prr	Preheat input regulator	6163	8	R	Word	N	0...1	flag
Ad2	Defrost end due to timeout	6163	16	R	Word	N	0...1	flag
nPA	Pressure switch	6163	32	R	Word	N	0...1	flag
LPA	Low pressure switch	6163	64	R	Word	N	0...1	flag
HPA	High pressure switch	6163	128	R	Word	N	0...1	flag
E10	RTC battery low alarm	6163	256	R	Word	N	0...1	flag
AtS	Regular watchdog 1 alarm	6162	512	R	Word	N	0...1	flag
HOt	Valve 1 MOP alarm	6163	512	R	Word	N	0...1	flag
tHA	Max valve 1 output alarm	6163	1024	R	Word	N	0...1	flag
LoP	Minimum voltage threshold exceeded	6163	2048	R	Word	N	0...1	flag
HiP	Maximum voltage threshold exceeded	6163	4096	R	Word	N	0...1	flag

Label	Description	Address	Filter	Type	Data_Size	CPL	Range	MU
E11	Power-Pack alarm	6163	32768	R	Word	N	0...1	flag
E15	No emergency closure alarm	6164	8	R	Word	N	0...1	flag
E08	Probe Pb8 error	6164	16	R	Word	N	0...1	flag
LEL	Level 1 refrigerant alarm	6164	32	R	Word	N	0...1	flag
LEH	Level 2 refrigerant alarm	6164	64	R	Word	N	0...1	flag
OFF	Stand-by	6167	1	R	Word	N	0...1	flag
C1	Compressor 1	6167	2	R	Word	N	0...1	flag
C2	Compressor 2	6167	4	R	Word	N	0...1	flag
RegAUX	Auxiliary regulator status	6167	8	R	Word	N	0...1	flag
Def1	Defrost 1	6167	16	R	Word	N	0...1	flag
Def2	Defrost 2	6167	32	R	Word	N	0...1	flag
FEv	Evaporator fans	6167	64	R	Word	N	0...1	flag
FCo	Condenser fans	6167	128	R	Word	N	0...1	flag
ALM	Alarm	6167	256	R	Word	N	0...1	flag
AUX	Auxiliary relay control output	6167	512	R	Word	N	0...1	flag
Lig	Light	6167	1024	R	Word	N	0...1	flag
DP	Deep Cooling	6167	2048	R	Word	N	0...1	flag
FH	Demisting heaters	6167	4096	R	Word	N	0...1	flag
SeR	Reduced set	6167	8192	R	Word	N	0...1	flag
ES	Energy saving	6167	16384	R	Word	N	0...1	flag
do	Door status	6167	32768	R	Word	N	0...1	flag
dyS	Dynamic setpoint active	6168	1	R	Word	N	0...1	flag
gDI	Digital input status for monitoring via supervision 1	6168	2	R	Word	N	0...1	flag
FCool	Forced cooling mode	6168	32	R	Word	N	0...1	flag
LAN	Number of devices recognized in LAN	6169	0	R	Word	N	0...255	num
nAU	Activates auxiliary output	2561	0	W	Word	N	0...1	flag
oAU	Deactivates auxiliary output	2562	0	W	Word	N	0...1	flag
nSB	Device on	2563	0	W	Word	N	0...1	flag
oSB	Device off	2564	0	W	Word	N	0...1	flag
nES	Activates energy saving function	2565	0	W	Word	N	0...1	flag
oNS	Deactivates energy saving function	2566	0	W	Word	N	0...1	flag
nSR	Activates economy mode	2567	0	W	Word	N	0...1	flag
oSR	Deactivates economy mode	2568	0	W	Word	N	0...1	flag
nLI	Switches lights on	2569	0	W	Word	N	0...1	flag
oLI	Switches lights off	2570	0	W	Word	N	0...1	flag
nBT	Locks terminal	2571	0	W	Word	N	0...1	flag
oBT	Unlocks terminal	2572	0	W	Word	N	0...1	flag
nDM	Manual Defrost activation	2573	0	W	Word	N	0...1	flag
oPV	Valve 1 opening control	2574	0	W	Word	N	0...1	flag
nPV	Valve 1 closing control	2575	0	W	Word	N	0...1	flag
nOS	Additional setpoint offset activation	2576	0	W	Word	N	0...1	flag
oOS	Additional setpoint offset deactivation	2577	0	W	Word	N	0...1	flag
dEC	Deep Cooling regulator activation	2578	0	W	Word	N	0...1	flag
CkUp	Updates clock	2579	0	W	Word	N	0...1	flag

Eliwell Controls srl

Via dell'Industria, 15 Z.I. Paludi
32016 Alpago (BL) Italia
Telephone +39 (0) 437 986 111
www.eliwell.com

Customer Technical Support

Telephone
E techsuppeliwell@schneider-electric.com

Sales

Telephone +39 (0) 437 986 100 (Italy)
Telephone +39 (0) 437 986 200 (other countries)
E saleseliwell@schneider-electric.com