

ID 970 MC

electronic controllers for refrigeration units with Milk Controller function



Eliwell electronic controllers for refrigeration units with "Milk Controller" function: specifically to control the milk mixer motor in the milk and cheese-making sector.

- 1 NTC/PTC probe
- 2 relays (compressor + mixer)
- TTL serial for Copy Card
- 230V power supply

- mixer function
 - parallel with compressor
 - independently
- display signal (LED) when mixer running

BUTTONS AND LEDS



UP

- Scrolls through the menu items
- Increases the values
- Activates manual defrost function



DOWN

- Scrolls through the menu items
- Decreases the values



fnc (press once)

- ESC function (quit) (hold down)
- Enable manually DCC function (par. H33)



set (press once)

- Accesses the setpoint
- Displays the alarms (if active)
- Displays Pb1 and Pb2 (see (hold down) Accesses the parameter programming menus



Compressor

- ON when the compressor is started up;
- blinking in case of delay, protection or blocked enabling



Defrost

- ON when defrosting;
- blinking in case of manual enabling



Alarm

- ON when the alarm is enabled;
- blinking when the alarm is silenced



Mixer

- ON when mixer running

*If the conditions for defrosting are not present, or if parameter OdO->0, the display will blink three times, to indicate that the operation will not be performed.

SETTING THE SET POINT - MACHINE STATUS MENU

a) Press the 'set' button and release it to access the machine status menu. In normal conditions, the labels for the Set point value is found in the menu. Once the 'SEt' label has been displayed, press the "set" button to display the Setpoint value. The Setpoint value appears on the display.

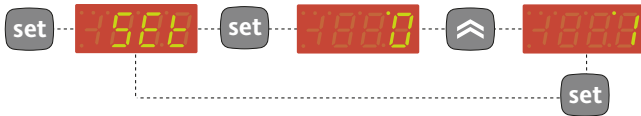

To change the Set point value, use the "UP" and "DOWN" buttons within 15 seconds. If you press the "set" button again, when the fnc button is pressed or 15 seconds elapse, the last value displayed will be stored and the "SEt" label will reappear on the display.

b) If alarms are present, the "AL" label appears. By using the "UP" and



"DOWN" buttons, you can scroll through all the folders in the menu: -AL: alarm folder (if alarms present, except for faulty probes/probe errors; -SEt: Set point setting folder; -Pb1: probe folder.

c) If an alarm condition exists when the Machine Status menu is accessed, the "AL" folder label appears.



(example: when maximum and minimum temperature alarms are present)

Use the UP and DOWN buttons to scroll through the list of active alarms and press 'set' to display the selected alarm.

PROGRAMMING MENU

To access the Programming menu, hold the "set" button down for more than 5 seconds.



- When the 'set' button is pressed, the first folder in the menu is displayed. (e.g.: "CP" folder)

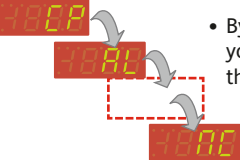

- By using the 'UP' e 'DOWN' buttons, you can scroll through all the folders in the programming menu

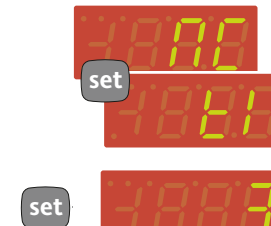

- By pressing the "set" button for the selected folder (in this example, 'MC/t1') the first parameter is displayed ('t1'). Use the "UP" and "DOWN" buttons to select the required parameter.
- Press "set" to display the selected parameter value and use the "UP" and "DOWN" buttons to change it.

Once the "set" button has been pressed (or the 15 second time out elapses) the new value is stored and the label of the corresponding parameter will be displayed.

PASSWORD

Access to parameter handling can be limited by using a password. The password can be enabled by setting the PA1 parameter in the 'diS' folder. The password is enabled if the value of the PA1 parameter is not 0.



- To enter the Programming menu hold the "set" button down for more than 5 seconds. If specified, the PASSWORD will be requested









- If the PA1 password is enabled (not 0) you will be asked to enter it. Do this by selecting the correct value using the UP and DOWN buttons and confirm by pressing the 'set' button.

If the password is not entered correctly, the device will display the 'PA1' label again and the step will have to be repeated.

COPY CARD

The Copy Card is an accessory connected to the TTL serial port used for quick programming of the unit parameters (upload and download parameter map to one or more units of the same type). upload (UL label), download (dL label) and copy card formatting (Fr label) operations are performed in the following way:

-   • The 'FPr' folder contains the commands necessary for use of the Copy Card. Press 'set' to access the functions.
-   • Use the 'UP' / 'DOWN' buttons to display the required function. Press the 'set' and uploading (or downloading) will be performed.
-   • If the operation is successful 'y' will be displayed, if it is not successful, 'n' will be displayed.

Download from reset

Connect the copy card when the instrument is OFF. The programming parameters are downloaded when the device is switched on. At the end of the lamp test, the following messages are displayed for about 5 seconds:

- dLY label if copy operation is successful
- DLn label if operation fails

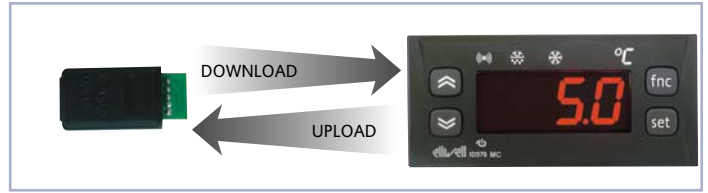

NOTE:

- after the parameters have been downloaded, the device uses the downloaded parameter map settings.
- see "FPr folder" in Parameter Table and Description of parameters

At each level in both menus, when the "fnc" button is pressed or the 15 second time out elapses, you are taken back to the higher display level and the last value on the display is stored.

ALARMS

LABEL	ALARM	CAUSE	EFFECTS	Resolving problems	NOTES
E1	Probe 1(control) faulty	<ul style="list-style-type: none"> • measuring of values outside the nominal reading range • control probe faulty/shorted/open probe 	"E1" label appears on display; Controller enabled as indicated by the On1 and OF1 parameters if programmed for the Duty Cycle	<ul style="list-style-type: none"> • check the probe wiring • replace the probe 	
AH1	High temperature alarm	<ul style="list-style-type: none"> • value read by probe 1 > HAL after time equal to "tAO". (see "MIN MAX ALARMS" and description of "HAL", "Att" and "tAO" parameters) 	Alarms created in the "AL" folder with the AH1/AH2 label	<ul style="list-style-type: none"> • Wait for temperature value read by probe 1 to fall below HAL 	
AL1	Low temperature alarm	<ul style="list-style-type: none"> • value read by probe 1 < LAL after time equal to "tAO". (see "MIN MAX ALARMS" and description of "LAL", "Att" and "tAO" parameters) 	Alarms created in the "AL" folder with the AL1/AL2 label	<ul style="list-style-type: none"> • Wait for temperature value read by probe 1 to go above LAL 	
			ALL see Alarm LED	ALL • Manual silencing by pressing button	ALL – If there are alarm exclusion times (see parameter table "AL" folder) the alarm will not be signalled.

MAX-MIN ALARMS

Temperature expressed as an absolute value (par "Att"=0) Abs(olute)

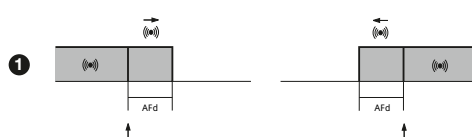

Minimum temperature alarm	Temperature lower than or equal to LAL (LAL with sign)
Maximum temperature alarm	Temperature greater than or equal to HAL (HAL with sign)
Minimum temperature alarm back swing	Temperature higher than or equal to LAL+AFd
Maximum temperature alarm back swing	Temperature lower than or equal to HAL-AFd

Temperature in relation to set point (par "Att"=1) rEL(ative)

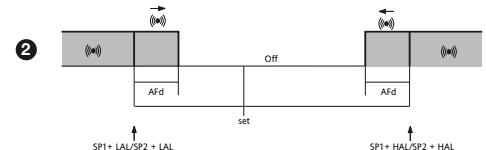

Temperature lower than or equal to set point +LAL (LAL positive only)
Temperature greater than or equal to set point +HAL (HAL positive only)
Temperature greater than or equal to set point + LAL + AFd
set point - LAL +AFd
Temperature lower than or equal to set point+HAL-AFd

if Att=rEL(ative) LAL must be negative: therefore set point+LAL<set point because set point+(-|LAL|)=set- |LAL|

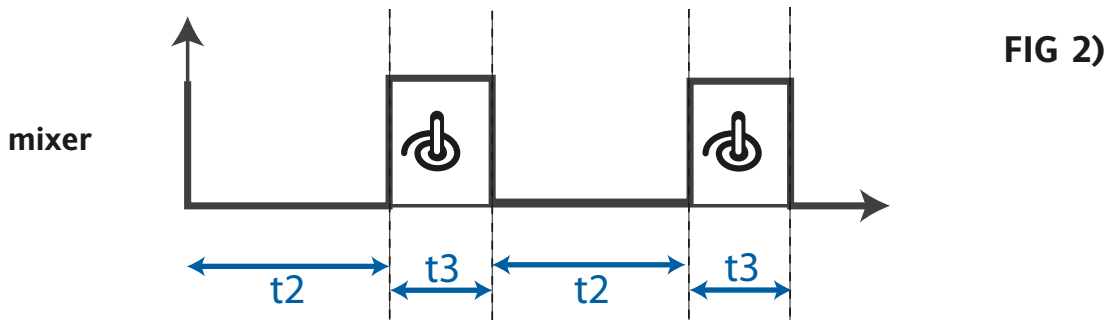
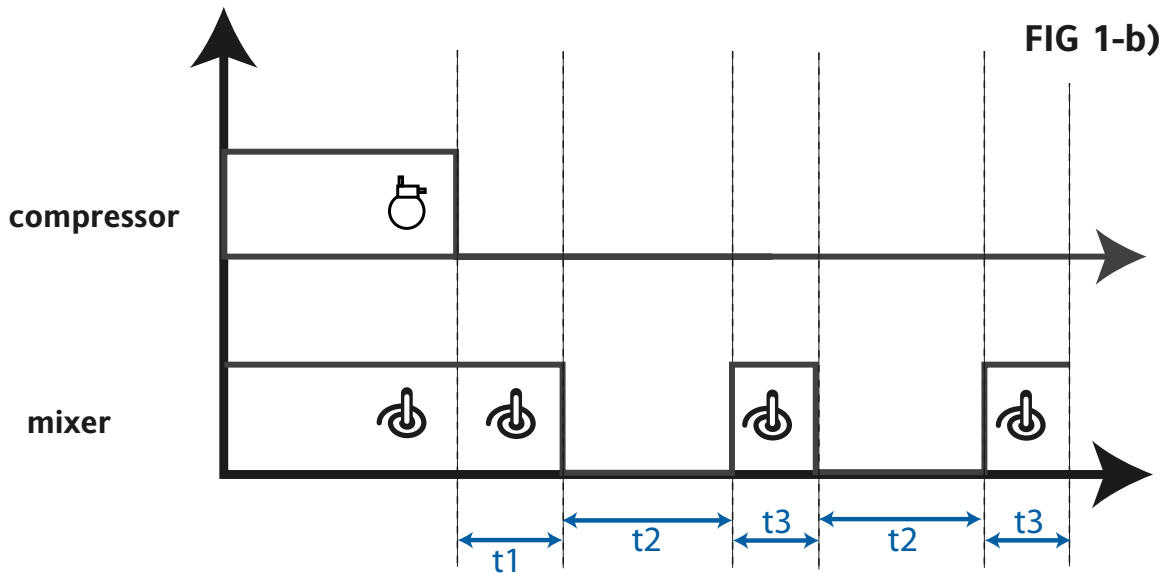
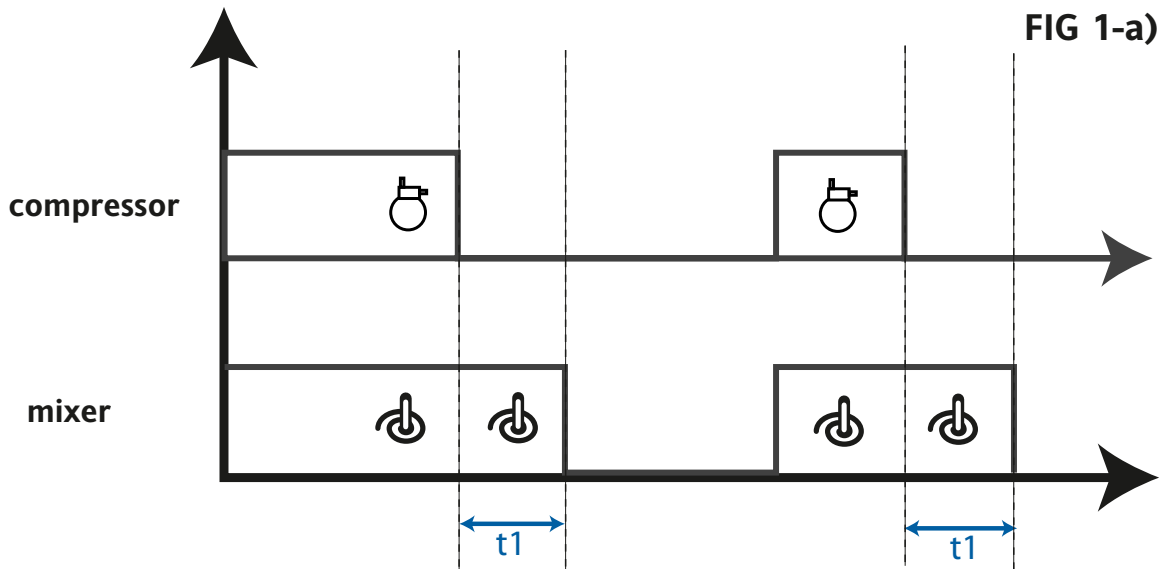

The Milk Controller (MC) function to run a milk mixer is managed by parameters in MC folder. There are 2 operating modes (determined by parameter **AtP**):

(1) Parallel with compressor (AtP=0):

(a) - see Fig 1-a)

When the compressor switches off, the mixer stays on for time **t1**.

(b) - see Fig. 2-b)

When the compressor stops after time **t2**, the mixer switches on for time **t3** before switching back off for time **t2** and so on;

When the compressor switches back on, example (a) is repeated.

(2) Cyclic (AtP=1):

see Fig. 2)

The mixer stays off for time **t2**; it switches on for time **t3** before switching back off for time **t2** and so on irrespective of the compressor.

KEYBOARD LOCKING

The instrument includes a facility for disabling the keyboard:

- using the keys (pressing **UP+DOWN simultaneously** for 2 seconds; see KEYS AND LEDS)
- by programming the “Loc” parameter (see folder with “diS” label).

If the keyboard is locked, you can access the “Programming” Menu by pressing the “set” key.

The Setpoint can also be viewed.

PARAMETERS TABLE

PAR.	RANGE	ELIWELL DEFAULT	U.M.	LEVEL
SETPOINT				
Set	LSE...HSE	0.0	°C/°F	1
CP Folder				
diF	0.1...30	2.0	°C/°F	1
HSE	LSE...302	99.0	°C/°F	1
LSE	-55.0...HSE	-50.0	°C/°F	1
Ont	0...250	0	min	1
OFt	0...250	1	min	1
dOn	0...250	0	sec	1
dOF	0...250	0	sec	1
dbi	0...250	1	sec	1
OdO	0...250	0	sec	1
DEF Folder				
dty	0/1/2	0	num	1
dit	0...250	6	h	1
dCt	0/1/2	1	num	1
dOH	0...59	0	min	1
dEt	1...250	30	min	1
dSt	-50.0...150	20.0	°C/°F	1
dPO	n/y	n	flag	1
dt	0...250	0	min	1
AL Folder				
Att	0/1	0	flag	1
AFd	1.0...50.0	2.0	°C/°F	1
HAL	LAL...150.0	50.0	°C/°F	1
LAL	-50.0...HAL	-50.0	°C/°F	1
PAO	0...10	0	h	1
tAO	0...250	0	min	1

PAR.	RANGE	ELIWELL DEFAULT	U.M.	LEVEL
diS Folder				
LOC	n/y	n	flag	1
PA1	0...250	0	num	1
ndt	n/y	y	flag	1
CA1	-12.0...12.0	0	°C/°F	1
ddl	0/1/2	1	num	1
dro	0/1	0	flag	1
CnF Folder				
** H00	0/1	1	flag	1
reL	/	/	/	/
tAb	/	/	/	/
MC Folder				
t1	0...250	5	min/h	1
t2	0...250	10	min/h	1
t3	0...250	10	min/h	1
AtP	0/1	0	flag	1
ACt	0/1	1	flag	1
Fpr Folder				
UL	/	/	/	/
dL	/	/	/	/
Fr	/	/	/	/

**Check the NTC/PTC default probe type installed (see label)

LEVEL column: indicates the visibility level of parameters accessed using a PASSWORD (see relevant paragraph).

If one or more parameters are modified, it is suggested to the switch off the controller after the modification and then switched back on.

MECHANICAL ASSEMBLY

The unit has been designed for panel-mounting: Drill a 29x71 mm hole, insert a tool and fix it in place with the brackets provided. Do not assemble the instrument in excessively humid or dirty locations since it is designed to be used in locations with normal pollution levels. Always make sure that the area next to the cooling openings of the tool is adequately ventilated.

ELECTRICAL CONNECTIONS

Warning! Always switch off machine before working on electrical connections. The instrument has screw terminals for connecting electrical cables with a maximum diameter of 2.5 mm² (only one conductor per terminal for power connections): for terminal capacity, see instrument label. The relay contacts are voltage-free. Do not exceed the maximum current allowed. For higher loads, use a suitable contactor. Make sure that the power voltage complies with the device voltage. The sensor has no connection polarity and can be extended using an ordinary bipolar cable (note that extending the probe may affect the electromagnetic compatibility (EMC) of the instrument: special care must be used when wiring). Probe cables, power supply cables and the TTL serial cable should be kept separate from power cables.

DESCRIPTION OF PARAMETERS

COMPRESSOR CONTROL (folders with label "CP")

diF Compressor relay activation differential: the compressor stops on reaching the Setpoint value (as indicated by the adjustment probe) and restarts at a temperature value equal to the Setpoint plus the value of the differential.
Note: the value 0 cannot be assumed.

HSE Maximum possible setpoint value.

LSE Minimum possible setpoint value.
NOTE: The two sets are interdependent: HSE (maximum set) cannot be less than LSE (minimum set) and vice versa

Ont Compressor activation time in the event of a faulty probe. If set to "1" with OfT set to "0", the compressor is always on, while with OfT >0 it operates in duty cycle mode.

OfT Compressor off time in the event of a faulty probe. If set to "1" with Ont at "0", the compressor is always off, while with Ont >0 it operates in duty cycle mode.

dOn Starting delay. The parameter indicates that a protection is active on the relay actuations of the generic compressor. Between the request and effective activation of the compressor relay, at least the specified time must elapse.

dOF Delay after switching off. The parameter indicates that the protection is active on compressor relay actuations. At least the indicated time must elapse between switch-off of the compressor relay and the successive switch-on.

dbi Delay between switch-ons. The indicated time must elapse between two subsequent switch-ons of the compressor.

Odo Delay time in activating the outputs after switch-on of the instrument or after a power failure. 0= not active.

DEFROSTING CONDITIONS

The instrument allows defrosting to be performed in the following conditions:

- the evaporator temperature is lower than the defrost end temperature set by the dSt parameter;
- manual defrosting is not already activated (see); in this case the request for automatic defrosting will be cancelled.

Automatic defrosting

In this case, defrosting takes place at time intervals set by parameter dit (=0 defrosting will not take place at all).

As mentioned above, if the parameter dit > 0 and defrosting conditions apply (see parameter dSt), defrosting will take place at fixed intervals and according to the parameter dCt

DEFROSTING CONTROL (folders with labels "dEF")

dtY Type of defrost.
0 = electrical defrosting;
1 = cycle inversion defrosting (hot gas);
2 = Free mode defrost.

dit Interval between the start of two subsequent defrosting operations.
0= the function is disabled (defrosting is NEVER performed)

dCt Selection of count mode for the defrosting interval.
0 = compressor hours of operation (DIGIFROST® method);
Defrosting active ONLY with the compressor on.
NOTE: compressor time of operation is counted regardless of the evaporator probe (counting is active if evaporator probe is absent or faulty).
1 = hours of appliance operation. Defrost counting is always active when the machine is on and starts at each power-on.
2 = compressor stop. Every time the compressor stops, a defrosting cycle is performed according to parameter dtY

dOH Defrost start delay time from start up of instrument.

dSt Defrosting end temperature (determined by the evaporator probe).

dEt Defrost time-out: determines the maximum duration of defrosting.

dPO Determines whether the instrument must enter **defrosting at start-up** (if the temperature measured by the evaporator allows this operation).
y = yes, starts defrosting at start-up; n = no, does not start defrosting at start-up.

ALARMS (folder with "AL" label)

Att Parameter "HAL" and "LAL" modes, as temperature absolute value or as differential relative to the Setpoint.
0 = absolute value; 1 = relative value.

Aft Alarm differential.

HAL Maximum temperature alarm. Temperature value (understood as distance from the Setpoint or as an absolute value based on Att) which if exceeded in an upward direction triggers the activation of the alarm signal.
See Max/Min. Alarm Diagram.

LAL Minimum temperature alarm. Temperature value (understood as distance from the Setpoint or as an absolute value based on Att) which if exceeded in a downward direction triggers the activation of the alarm signal.
See Max/Min. Alarm Diagram.

PAO Alarm exclusion time after instrument is switched on following a power failure.

tAO Temperature alarm signal delay time.

DISPLAY (folder with "diS" label)

LOC Keyboard locking. It is still possible to enter parameter programming and modify the parameters, including the status of this parameter, in order to allow keyboard unlocking. y = yes (keyboard locked); n = no.

PA1 When enabled (value other than 0), it constitutes the access key for level 1 parameters.

ndt View with decimal point.
y = yes (view with decimal point); n = no (only integers).

CA1 Calibration 1. Positive or negative temperature value added to the value read by probe

ddl Viewing mode during defrosting.
0 = shows the temperature read by the thermostat probe;
1 = locks the reading at the temperature value read by thermostat probe when defrosting starts and until the next time the Setpoint value is reached;
2 = displays the label "dEF" during defrosting and until the next time the Setpoint value is reached.

dro Select °C or °F for displaying the temperature read by the probe.
0 = °C, 1 = °F. **PLEASE NOTE: switching between °C and °F or vice versa DOES NOT modify the setpoint, differential, etc. (for example set=10°C become 10°F).**

CONFIGURATION (folder with "CnF" label)

H00 Selection of probe type. 0 = PTC; 1 = NTC.

rEL Device version: read only parameter.

tAb Reserved: read-only parameter.

MIXER (directory with label "MC")

t1 delay before mixer switches off (after compressor switches off).
In hours/minutes depending on ACt.

t2 Mixer OFF time (with compressor off if AtP=0).
In hours/minutes depending on ACt.

t3 Mixer ON time (with compressor off if AtP=0).
In hours/minutes depending on ACt.

AtP Mixer type. Mixer operation mode.
0 = parallel with compressor;
1 = cyclic operation.

ACt Mixer control time. Units of measure for mixer times
0 = hours;
1 = minutes.

COPY CARD (folder with label "Fpr") - (see "Copy Card" section)

UL Upload. Programming parameter transfer from instrument to Copy Card.

dL Download. Programming parameter transfer from Copy Card to instrument.

Fr Format. Erasing all parameters in the key.
PLEASE NOTE: using the "Fr" parameter (key formatting) results in permanent loss of data inserted in key. The operation cannot be cancelled.

CONDITIONS OF USE

PERMITTED USE

For safety reasons the instrument must be installed and used in accordance with the instructions supplied. Users must not be able to access parts with dangerous voltage levels under normal operating conditions. The device must be suitably protected from water and dust according to the specific application and only be accessible using special tools (except for the front keypad). The device can be fitted to equipment for household use and/or similar use in the refrigeration sector and has been tested with regard to safety in accordance with the European harmonized reference standards: It is classified as follows:

- as an automatic electronic control device to be integrated as regards its construction;
- as a 1 B type operated control device as regards its automatic operating features;
- as a Class A device in relation to the category and structure of the software.

UNPERMITTED USE

The use of the unit for applications other than those described above is forbidden. It should be noted that the relay contacts supplied with the device are functional and therefore exposed to potential faults. Any protection devices required to comply with product requirements or dictated by common sense due to obvious safety reasons should be installed externally.

Front protection	IP65
Casing	PC+ABS UL94 V-0 resin plastic body, polycarbonate front, thermoplastic resin buttons.
Dimensions	front panel 74x32 mm, depth 59 mm (terminals excluded).
Assembly	on panel, with drilling template 71x29 mm (+0.2/-0.1 mm).
Operating temperature	-5...55 °C.
Storage temperature	-30...85 °C.
Ambient operating and storage humidity	10...90 % RH (non-condensing).
Display range	• NTC probe: -50.0...110.0°C (-58...230°F); • PTC probe: -55.0...140.0°C (-67...284°F) on display 3 1/2 digits + sign.
Analogue input	2 PTC or NTC input (parameter selectable).
Serial	TTL for connection to Copy Card
Digital outputs (configurable)	3 outputs on relays: • (A) 1 output on SPDT relay 8(3)A 1/2 hp 250V~, • (B) 1 output on SPST relay 8(3)A 1/2 hp 250V~, (for relay capacity, see instrument label).
Buzzer	if present
Measurement range	from -55 a 140 °C.
Accuracy	better than 0.5% of bottom scale + 1 digit.
Resolution	0.1°C (0.1°F up to +199.9°F; 1°F above).
Power consumption	3 VA max
Power supply	230V~ ±10% 50/60 Hz
PLEASE NOTE: please refer to label on the instrument for relay capacity, power supply and terminals layout.	

TERMINALS

1 - 2	N.O. mixer relay
1 - 3	N.C. mixer relay
4 - 5	Compressor relay output
6 - 7	Power supply 230V 3VA max.
8 - 10	Probe Pb1 input (thermostat)
A	TTL input for Copy Card

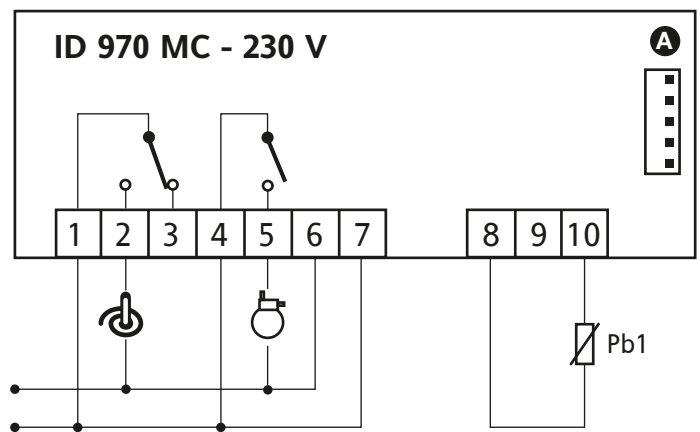

The technical characteristics in this document concerning measurements (range, accuracy, resolution, etc.) refer to the instrument in the strictest sense and not to any accessories provided such as probes, for example. This means, for example, that an error introduced by the probe is added to any error that is typical of the instrument.

RESPONSIBILITY AND RESIDUAL RISKS

Eliwell shall not be liable for any damages deriving from:

- installation/use other than that prescribed and, in particular, which does not comply with the safety standards specified in the regulations and/or those given herein;
- use on boards which do not guarantee proper protection against electric shock, water or dust when assembled;
- use on boards which allow dangerous parts to be accessed without the use of tools;
- tampering with and/or alteration of the product;
- installation/use on boards that do not comply with the standards and regulations in force.

DISCLAIMER

This document is exclusive property of Eliwell and cannot be reproduced and circulated unless expressly authorized by Eliwell. Although Eliwell has taken all possible measures to guarantee the accuracy of this document, it declines any responsibility for any damage arising out of its use. The same applies to any person or company involved in preparing and writing this document. Eliwell reserves the right to make any changes or improvements without prior notice and at any time.



ELIWELL CONTROLS s.r.l.
Via dell'Industria, 15 Zona Industriale Paludi
32010 Pieve d'Alpago (BL) ITALY
Telephone +39 0437 986111
Facsimile +39 0437 989066
Internet <http://www.eliwell.it>

Technical Customer Support:
Telephone +39 0437 986300
Email: techsuppeliwell@invensyscontrols.com

Invensys Controls Europe
An Invensys Company

12/2006 -GB-
cod. 91544070

ISO 9001

