

eliwell

by Schneider Electric

Cold Room Application

free smart



PLC application for seasoning cycle cells

vers. 1.1

TABLE OF CONTENTS

1	Use of device.....	5
1.1	Conditions of use.....	5
1.2	Responsibility and residual risks.....	5
1.3	Disclaimer.....	5
2	How to use this manual.....	6
3	Introduction.....	7
3.1	Before reading.....	7
3.2	General description.....	7
4	User interface.....	8
4.1	Keys.....	8
4.2	LED.....	9
4.2.1	Status and Operating Modes.....	9
4.2.2	Values and Unit of Measure.....	9
4.2.3	Utilities.....	10
4.3	Main view.....	10
4.4	Start up.....	11
4.5	Status menu.....	11
4.6	Changing setpoint.....	12
4.6.1	Status menu table.....	12
4.7	Running hours.....	14
4.8	Active alarms menu.....	14
4.9	Hystorical Alarms menu.....	15
4.10	Parameters menu.....	17
4.11	Main Display view.....	18
5	I/O Configuration.....	20
5.1	Analog Input configuration.....	20
5.2	Digital Input configuration.....	20
5.3	Digital output (relay) configuration.....	21
5.4	Analog output configuration.....	22
5.5	Communication channels configuration.....	22
5.6	Default I/O configuration summary and Wiring Diagram.....	22
5.7	Wiring Diagram 4 DIN model default settings	24
5.8	Wiring Diagram 32x74 panel mount model default settings.....	24
6	Compressor.....	25
6.1	Compressor configuration.....	25
6.2	Compressor operating conditions.....	25
6.2.1	Compressor protection in the event of probe failure (duty cycle).....	25
6.2.2	Compressor safety times.....	26
7	Heating / Cooling.....	28
7.1	Heating.....	28
7.2	Cooling.....	28
7.3	Neutral zone.....	29
7.4	Heating/Cooling.....	29
8	Defrost.....	31
8.1	Defrost conditions and function.....	31
8.1.1	Automatic defrost.....	31
8.1.2	Automatic defrost with Real Time Clock.....	32
8.1.3	Manual defrost.....	32
8.1.4	External or manual defrost.....	32
8.2	Defrost modes.....	33
8.2.1	Defrost with compressor stopped (DEFAULT).....	33
8.2.2	Defrost with electrical heaters.....	33
8.2.3	Hot gas defrost.....	34
8.2.4	Defrost in FREE mode.....	34
8.2.5	Defrost regulator protection and constraints.....	34
9	Evaporator fans.....	35

9.1	Physical configuration.....	35
9.2	Operating conditions.....	35
9.3	Operating modes.....	35
10	Ventilation fans.....	36
10.1	Physical configuration.....	36
10.2	Operating conditions.....	36
10.3	Operating modes.....	36
10.4	Programming.....	36
11	Analog output.....	37
11.1	Physical configuration.....	37
11.2	Operating conditions.....	37
11.3	Operating modes.....	37
11.3.1	Start-up time.....	37
11.3.2	Regulation on compressor request.....	37
11.3.3	Cut-off bypass time.....	37
11.3.4	Pre-ventilation.....	37
11.3.5	Regulation.....	37
11.4	Programming.....	38
12	Pressure switch.....	39
12.1	Operating modes.....	39
12.1.1	Alarm reset.....	39
13	Humidity.....	40
13.1	Operating conditions.....	40
13.2	Humidification.....	40
13.2.1	Physical configuration.....	40
13.2.2	Operating modes.....	40
13.3	Dehumidification.....	40
13.3.1	Dehumidification modes.....	40
13.3.2	Physical configuration.....	41
13.3.3	Operating modes.....	41
13.4	Programming.....	41
14	Thermal profiles.....	42
14.1	Programming.....	42
14.2	Enabling the program.....	42
14.2.1	Shortcuts Enabling /disabling thermal profiles	42
14.3	Program control.....	43
14.3.1	Program START.....	43
14.3.2	Program RUN.....	43
14.3.3	Program STOP.....	43
14.3.4	Program RESET.....	44
14.4	STEP behavior.....	44
14.5	Example.....	45
15	Alarms and diagnostics.....	46
15.1	Probe error.....	46
15.2	Alarms.....	46
15.3	High/Low (temperature / relative humidity) alarms.....	47
15.3.1	High/Low temperature alarms configuration.....	47
15.3.2	High/Low humidity alarms configuration.....	48
16	Parameters.....	50
16.1.1	Parameter menu.....	50
16.2	rtC = Update Clock	51
16.3	dF1 = Defrost time.....	51
16.4	dF1 = Thermal profiles	51
16.5	Compressor.....	51
16.6	Humidity.....	52
16.7	Defrost.....	52
16.8	Evaporator fans.....	53
16.9	Analog output.....	53

16.10	Ventilation fans.....	55
16.11	Alarms.....	55
16.12	Light and digital inputs.....	56
16.13	Configuration.....	57
16.14	Programming reference.....	58
16.14.1	Parameter tables.....	59
16.14.2	Modbus table.....	60
16.14.3	Client table (Status Variables).....	77

1 USE OF DEVICE

1.1 Conditions of use

Permitted use

For safety reasons, the device must be installed and used in accordance with the instructions provided. In particular, parts carrying dangerous voltages must not be accessible under normal conditions.

The device must be adequately protected from water and dust with regard to the application, and must only be accessible using tools (with the exception of the front panel).

The device is suitable for use in household and/or similar air conditioning appliances or installations and has been tested for safety aspects in accordance with harmonized European reference standards.

Improper Use

Any use other than that expressly permitted is prohibited.

The relay contacts supplied are of the functional type and are subject to fault (since they are electronically controlled they are prone to short-circuiting or remaining open). Any protection devices specified in product standards or suggested by common sense for obvious safety requirements must be installed externally to the device.

1.2 Responsibility and residual risks

Eliwell is not liable for damage caused by:

- Installation/use other than expressly specified and, in particular, in conflict with the safety prescriptions set down in regulations and/or specified in this document;
- Use on panels that do not provide adequate protection against electric shocks, water or dust in the adopted mounting conditions.
- Use on panels allowing access to dangerous parts without having to use tools.
- Tampering with and/or modification of the product.
- Installation/use on panels that do not comply with statutory laws and regulations.

1.3 Disclaimer

This document is the exclusive property of **Eliwell Controls srl** and may not be reproduced or circulated without the express permission of **Eliwell Controls srl**.

While all possible care has been taken to ensure the accuracy of this document, **Eliwell Controls srl** cannot accept liability for any damage resulting from its use.

The same applies to any person or company involved in preparing and editing this document. **Eliwell Controls srl** reserves the right to make aesthetic or functional changes at any time without notice.

2 HOW TO USE THIS MANUAL

This manual is designed to permit quick, easy reference with the following features:

References

References column:

A column to the left of the text contains references to subjects discussed in the text to help you locate the information you need quickly and easily.

Cross references

Cross references:

All words written in italics are referenced in the subject index to help you find the page containing details on this subject; supposing you read the following text:

"*compressor, evaporator fans* and *defrost* output are deactivated and alarm manual rearm is required"

The italics mean that you will find a reference to the page on the topic of compressor / evaporator fans / defrost listed under the item compressor / evaporator fans / compressor (respectively).

If you are consulting the manual on-line (using a computer), words which appear in italics are hyperlinks: just click on a word in italics with the mouse to go directly to the part of the manual that discusses this topic.

Icons for emphasis

Some segments of text are marked by icons appearing in the references column with the meanings specified below:



Warning!: information which is essential for preventing negative consequences for the system or a hazard to personnel, instruments, data, etc., and which users must read with care.



Take note: information on the topic under discussion which the user ought to keep in mind.



Tip: a recommendation which may help the user to understand and make use of the information supplied on the topic under discussion.

3 INTRODUCTION

3.1 Before reading

For all general information concerning the programmable controller FREE Smart (cabling hardware, I/O mapping, technical data and programming BIOS, etc.) not included in this document, refer to the manual

9MA10251.xx_mm-yy_FREE_Smart_SKP_SKW_UserGuide

3.2 General description

“Cold Room Application” is an application targeting the FREE Smart programmable controller family which can control functions in both conventional and ventilated cold rooms, including combined temperature and humidity control.

It is suited to the control of commercial and industrial cold cells and, thanks to the wide number of outputs available, provides control of all associated functions, including lights, alarms, fans, humidification / dehumidification, and heating.

The curing/ageing/storing cycle consists of 1 program with 8 climate profiles; completely configurable by the user, the combined control of temperature and relative humidity as well as defrosting makes “Cold Room Application” on FREE Smart the best electronic solution for curing and keeping all food and consumable products.

The graphic interface features a 7-segment LED display | 4 digits.

Menus are user-friendly and parameters can be easily viewed thanks to the large surface area of the display itself.

Applications:

- butchers;
- sausage and salami production;
- delicatessens;
- cheese production;
- pasta production;
- vegetable production;
- food storage cells (fruit, vegetables, meat);
- abattoirs;
- dryers for wood, skins, paper, marble.

4 USER INTERFACE

The front panel of the device functions as user interface and is used to perform all operations relating to the device.

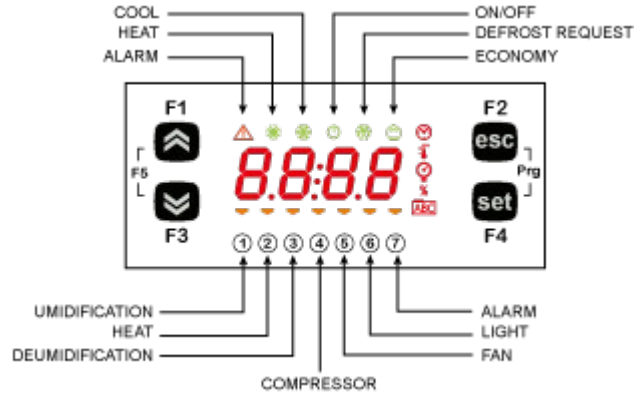

4.1 Keys

FREE Smart programmable controller has 4 keys. Each key is associated with:

- a direct action, simply bound to the key press;
- a function associated to a long key press (press and hold for about 3 seconds).

The action/function associated to a key depends on the currently displayed menu, according to the following table.

Actions/Functions associated to keys

Key	Single press	Long key press	Edit mode
UP	Increment value Select previous element	Start/Stop thermal profiles program Configurable by Parameter UPLF	Increment value of selected digit
DOWN	Decrement value Select next element	Manual Defrost Configurable by Parameter DWLF	Decrement value of selected digit
esc	Status / Parameters menu Back to previous page Thermal profiles program control panel Reset thermal profiles program Other menus Select previous element	Alarms Manual reset Configurable by Parameter ESCF	Exit without saving
set	Enter edit mode Enter sub-menu	ON/OFF device Configurable by Parameter SEtF	Exit and save

keys – combined action

The action/function associated to combined pressing of two keys depends on the currently displayed menu, according to the following table.

Keys		Combined pressing
UP+ DOWN	F5	Lets you switch from the BIOS menu in the main display to the main display of the PLC menu (if present) See FREE Studio Quick Start for details
esc+set	Prg	Open programming menu







4.2 LED

LED meaning



The display has 18 icons (LEDs) split into 3 categories:

1. Status and Operating Modes
2. Values and Units of Measure
2. Utilities

4.2.1 Status and Operating Modes

LED		colour	Steady ON	Steady blinking
Alarm		red	Alarms At least one alarm is active	No alarm active, but at least one manual rearm alarm is waiting for reset
Heat		green	Heater is active	-
Cool		green	Compressor is active	-
ON / OFF		green	Economy mode is active	-
Defrost		green	Defrost is active	-
Economy		green	Economy mode is active	-

4.2.2 Values and Unit of Measure

LED		colour	Steady ON	blinking
Clock (RTC)		red	View date / hour	Step running
°C	°C	red	°C	-
bar	Bar	red	bar	-
% U.R.	%R.H.	red	% R.H.	-
Menu		red	Menu BIOS	-

4.2.3 Utilities

LED		colour	Steady ON Resource running	blinking
1	▼	amber	Umidification	-
2	▼	amber	Heat	-
3	▼	amber	Deumidification	-
4	▼	amber	Compressor	Compressor activation request pending
5	▼	amber	Fans	-
6	▼	amber	Light	-
7	▼	amber	Alarm	-

4.3 Main view

Access to folders is organised into menus.

Access is determined by the keys on the front panel

There are 2 menus:

- **BIOS menu** to manage **Status** menu and **Configuration CL / CF parameter's menu**
- **PLC EWHT menu** to manage Status menu and **Programming** menu

BIOS Menu

If the target is 'empty', e.g. there is no IEC application on the device, the FREE Smart will display the message **FrEE**.

Otherwise (the FREE Smart is loaded with an IEC application) the developer's default message displays, or PLC if no default has been set.



Access Status menu



Access Programming menu

Configuration CL e CF

(CF parameters password protected)

PLC EWHT Menu



Press the UP and DOWN keys (F1+F3) together to access to the BIOS menu.
F1+F3



Access Status menu



Access Programming menu

4.4 Start up

When you first turn on the device or restart the instrument, after the lamp test, the label FrEE appears for a second and following the device version information.



Shows Televis ID version
see Status Menu, rEL folder
tid parameter
and then in sequence

Shows UEr1 parameter value

Shows UEr1 parameter value

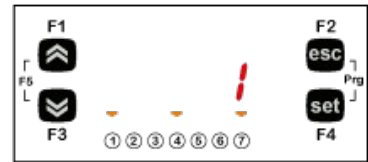
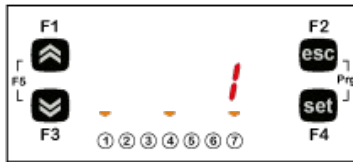

4.5 Status menu

FREE Smart has a 'Status' menu where you can view system resources and / or modify main display view, changing SetPoint, startup cycles thermal profiles, including commands such as Reset alarm history etc.

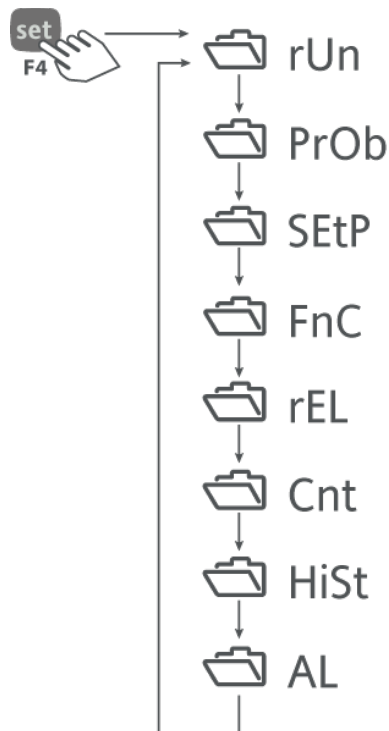

You can change both temperature and humidity setpoint, to be used in regulation, directly from the main view.

4.6 Changing setpoint

Just select the set key in the main view ...



Access Status menu



Access Status menu,

first folder / label

Use the "UP" and "DOWN" keys to scroll all labels



Changing SetPoint

**Setpoint
Reference
Table**

Inside SEtP folder...

Following table summarize the 3 setpoints.

Label	Description
SEt1	SetPoint 1
SEt2	SetPoint 2
SrH	SetPoint %RH

4.6.1 Status menu table

The following table shows the parameters, split by folder / menu, in the Status menu

Folder	Display name	Resources	Read /Write
Thermal Profiles	rUn	SCSt	Current Step number
		rSS	Start / Stop thermal profile
		rrES	Reset thermal profile
		rdiS	Reset thermal profile
Probes	PrOb	Pb1	Room probe
		Pb2	Evaporat probe
		Pb3	Humidity probe
		Pb4	AO regulation probe
SetPoint	SEtP	SEt1	SetPoint 1
		SEt2	SetPoint 2
		SrH	SetPoint %RH
Commands	FnC	LSt	Locale ON/OFF State
		FECr	Economy
		FAUr	Fans
		FrAr	Alarms Reset
		FrCr	Counters Reset
		rHiS	Hystorical Alarms Reset

Folder	Display name	Resources		Read /Write
Version	rEL	UEr1	Versione	Read only
		UEr2	Versione	
		tid	Televis ID	
Counters	Cnt	PrAC	Counters	Read only
		UUt	Compressor Running Hours	
		CUt	Compressor Running Hours	
Registers	HiSt	HiSF	Alarms number recorded in Hystorical Alarms menu	Read only
		HYSP	Position recorded in Hystorical Alarms menu (from 1 to 8)	Read /Write
		HYSC	Error code recorded in Hystorical Alarms menu (1, 2, 3 etc)	Read only
		HYSd	Date recorded in Hystorical Alarms menu (dd.mm format)	Read only
		HYSst	Hours and minutes recorded in Hystorical Alarms menu (hh:mm format)	Read only
		HYS1	Current event room probe value recorded	Read only
		HYS2	Current event evaporator probe value recorded	Read only
		HYS3	Current event hunidity probe value recorded	Read only
Allarmi	AL			

4.7 Running hours

The counter menu displays the hours of operation of the unit and the compressor running hours plus the pressure switch alarm event counter



pressure switch alarm event counter

Unit / device running hours

compressor running hours

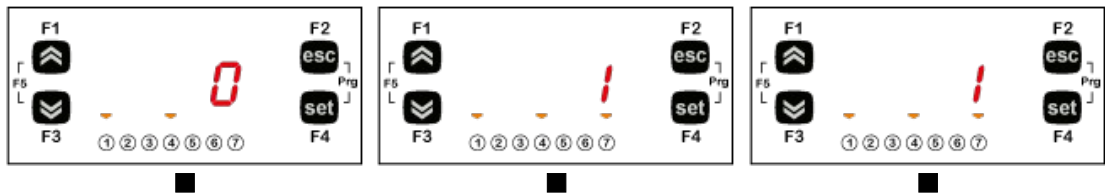

4.8 Active alarms menu

Active alarms menu shows the whole set of currently active alarms and those waiting for manual reset. When more than one alarm is active, you have to scroll the list with UP and DOWN keys.

Alarms Menu

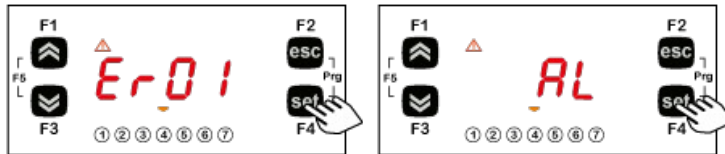

Access to Status menu

Press set to view current running alarms

Alarm reset command

From the FnC folder you can reset the alarm log.

The command to reset is **rHiS**

Request alarm history reset 0 = OK / Idle, 1 = hysterical reset request

4.9 Hystorical Alarms menu

The Alarm Historical Menu displays a list of the last 10 alarms recorded by the device.

Once it reaches 10 alarms recorded, in the event of activation of a new alarm, the oldest alarm will be overwritten with the new alarm.

HIST menu contains all the information about the historical alarms.

In the menu, the first folder **HYSP** summarizes the number of alarms in the historical.

= 0 if no alarm conditions are present.

HiSt – HiSF Menu



Access to the Status menu

The first label to be displayed is **rUn**

Scroll through the folders with the UP and DOWN keys until you find **HiSt** label



Alarm History **HiSt** Menu



Displays the number of alarms in the historic

value 0 = no alarm registered

value = 9 Upper limit alarms recorded

In the menu, the second folder **HYSP** indicates the location in the historic alarm.

This value can be set, unlike all other folders that are **Read only**

HiSt – HYSP Menu



Access to the Status menu

The first label to be displayed is **rUn**

Scroll through the folders with the UP and DOWN keys until you find **HiSt** label



Alarm History **HiSt** Menu



Location in the historic alarm

Number can be set from 0 to 9

with the UP and DOWN keys

In the **Hist** menu, once defined which alarm to read, scroll through the folders with the UP and DOWN keys to display in Read only mode the following information:

<p>Historical Alarm code number</p>	<p>Historical Alarm date (dd:mm)</p>	<p>Historical Alarm hour (hh:mm)</p>

The probe values if in error are displayed as Out of range (**Outr**)

<p>Room probe value recorded in the current event</p>	<p>Evaporator probe value recorded in the current event</p>	<p>Humidity probe value recorded in the current event</p>

4.10 Parameters menu

To access parameters/BIOS parameters menu, access rights have to be granted by successfully log in - that is, by entering a password

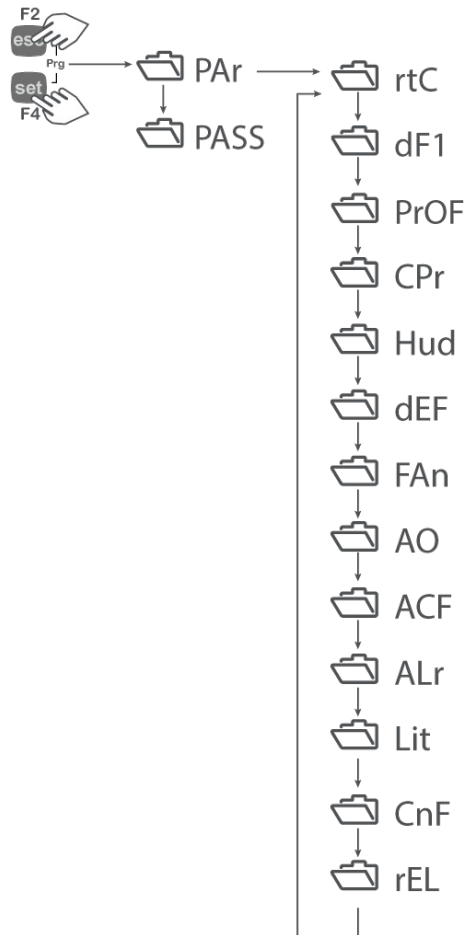

Password entry

Access to the Parameters menu and BIOS parameters is password protected. The password can be entered through the **PASS** menu

Setting the Password



To access the menu parameters press the esc and the set button simultaneously .

You will enter the menu PAr



Press UP to view PASS menu



Press set and enter the password by using the UP and DOWN buttons.

Confirm with set key

Changing a parameter

Access parameters menu



To access the menu parameters press the esc and the set button simultaneously .

You will enter the menu PAR

Press set to enter the first folder available in parameters' menu

Press set again to view and change the value with the UP and DOWN buttons.

Confirm with set key

4.11 Main Display view

Default view

The value to be displayed can be set by parameter

The display can be fixed or rotating

Displaying fixed (static) is defined by parameter **dFSS**

FdSS Parameter	Values	Notes	Condizione
1	Pb1	Room probe DEFAULT	H41 ≠ 0
3	Pb2	Evaporator probe	H42 ≠ 0
5	Pb3	Humidity probe	H43 ≠ 0
7	Pb4	Analoge Output probe	H44 ≠ 0
9	StEP Thermal profile	Number from 1 to 8	
10	Stato Thermal profile	Visualizza StAr / rUn / StOP	

The display rotation (dynamic) is enabled or disabled by parameter **FdMO**

As default it is disabled. If forced to rotation the display will be show probe values as described in the above table

Note. The values read by the probes will be displayed if H41, H42, H43 H44 are ≠0, respectively

Fixed display (static)

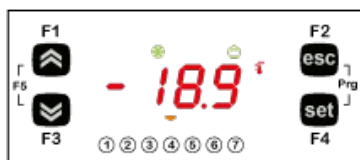

dFSS=1 room probe



dFSS=3 evaporator probe



dFSS=5 humidity control probe





dFSS=7 AO regulation probe



dFSS=9 thermal profile



dFSS=10 thermal profile state

Display rotation (dynamic)

The six variables described above are displayed in rotation if parameter **FdMO = 1**

Example of dynamic visualization:



Pb1 probe value

Pb2 probe value

Pb3 probe value

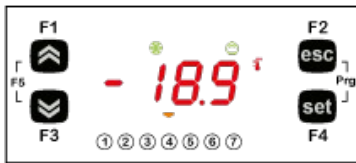

Pb4 probe value

Step number

Step running

5 I/O CONFIGURATION



Please refer to FREE Smart Installation Manual, for important information about electric connections between the FREE Smart programmable controller and devices connected to its I/O.

Device configuration is determined by the values of I/O configuration parameters available in the configuration menu.

5.1 Analog Input configuration

Probe association to analog input

Probes **Pb1** ... **Pb4** are associated to FREE Smart controller's analog inputs by means of **1180: H41** ... **1183: H44** parameters.

The same analog input can be assigned to more than one logical probe. For example, it is possible to use the same feedback for both *thermoregulation* (**Pb1**) and the *cut-off regulator* regulating the *analog output* (**Pb4**).

The table below lists default values for parameters **1180: H41** ... **1183: H44**.

Parameter	Meaning
1180: H41	Cell temperature (<i>thermoregulation</i>)
1181: H42	Evaporator temperature (<i>defrost</i>)
1182: H43	Cell relative humidity (<i>relative humidity regulation</i>)
1183: H44	<i>Cut-off regulator</i> feedback

You can also disable one or more probes by setting the related parameter to Disabled: in this case, the corresponding regulation function is inhibited.

Analog input physical configuration

Physical characteristics (type - NTC/voltage/current -, start of scale, full scale, calibration) of FREE Smart programmable controller's analog inputs are set by means of its BIOS parameters, discussed in FREE Smart Installation Manual and available in the BIOS parameters menu accessed from the main menu.

5.2 Digital Input configuration

Digital input configuration table

The application uses FREE Smart programmable controller's first two digital inputs with the meaning determined by the parameters **1159: H11** e **1160: H12**.

The table below records the association between parameters and digital input configuration.

Parameter	Description	Range	Meaning	Default value
1159: H11	Digital input 1 (DIL1) configuration	-21...+21	See following tables	+4=NO: Door switch
1160: H12	Digital input 2 (DIL2) configuration	-21...+21	See following tables	+5=NO: External alarm
H13	Digital input 3 (DIL3) configuration	-21...+21	See following tables	+11=NO: Pressure Switch
H14	Digital input 4 (DIL4) configuration	-21...+21	See following tables	+21=NO: AUTO MODE
H15	Digital input 5 (DIL5) configuration	-21...+21	See following tables	+5=NO: External Alarm
H16	Digital input 6 (DIL6) configuration	-21...+21	See following tables	+1=NO: Defrost request

The meaning of single values of **1159: H11** e **1160: H12** parameters is reported in the following table.

Value	Description	Notes
0	Disabled	
±1	<i>Defrost</i> request	Toggle mode
±2	Economy mode (reduced setpoint)	
±4	Door switch	
±5	External alarm	
±7	Stand-by	
±11	<i>Pressure switch</i>	
±14	Light relay activation	
±15	<i>Ventilation fans</i> relay activation	
±18	Panic alarm	
±20	<i>Heating/Cooling mode</i> selection	
±21	Start/Stop <i>thermal profiles</i> program	Toggle mode

Digital input polarity

Digital input polarity is configured according to the following rules:

		Value	Description
+	NO	Positive	Active when contact is open (Normally Open)
-	NC	Negative	Active when contact is closed (Normally Closed)

Digital input priority

If both **1159: H11** and **1160: H12** are set to the same value, digital input 1 takes the priority over digital input 2 – that is, digital input 2 is ignored.

5.3 Digital output (relay) configuration



Please refer to FREE Smart Installation Manual for the available number of relays and their capacity and for the meaning of the symbols found on labels supplied with the device.

Digital output configuration

The following table explains the meaning the application assigns to FREE Smart programmable controller's digital outputs and the parameters used to configure them.

Description	Meaning	Configuration	Default
Digital output 1 (DO1)	<i>Humidifier</i>	Fixed (not configurable)	<i>Humidifier</i>
Digital output 2 (DO2)	<i>Heater</i>	Fixed (not configurable)	<i>Heater</i>
Digital output 3 (DO3)	<i>Dehumidifier</i> / Electric <i>defrost</i> relay	Configurable (parameter H23)	Dehumidifier
Digital output 4 (DO4)	<i>Compressor</i>	Fixed (not configurable)	<i>Compressor</i>
Digital output 5 (DO5)	<i>Evaporator fans</i>	Fixed (not configurable)	<i>Evaporator fans</i>
Digital output 6 (DO6)	Disabled / Light / Alarm / <i>Ventilation fans</i>	Configurable (parameter 1168: H26)	Light
Analogue	Disabled / Light / Alarm / <i>Ventilation fans</i>	Configurable	OC Alarm

Description	Meaning	Configuration	Default
output (AO2)		(parameter 1169: H27)	

5.4 Analog output configuration

Application manages one analog output as the output of a widely-parametric *cut-off regulator*.

Analog output physical configuration

Physical characteristics (type - On-Off/voltage/current -, etc.) of FREE Smart programmable controller's analog output are set by means of its BIOS parameters, discussed in FREE Smart Installation Manual and available in the BIOS parameters menu accessed from the main menu.

5.5 Communication channels configuration

BIOS parameters menu, available in the application main menu, gives access also to configuration parameters of the communication channels available on the FREE Smart programmable controller. See FREE Smart Installation Manual for details.

5.6 Default I/O configuration summary and Wiring Diagram

I/O configuration summary

The following table explains the meaning the application assigns to FREE Smart programmable controller's I/Os and the parameters used to configure them.

Description	Meaning	Configuration	Default
Analogue input 1 (Pb1)	Cell temperature (<i>thermoregulation</i>)	Configurable (parameter 1180: H41)	AI1
Analogue input 2 (Pb2)	Evaporator temperature (<i>defrost</i>)	Configurable (parameter 1181: H42)	AI2
Analogue input 3 (Pb3)	Cell relative humidity (<i>relative humidity regulation</i>)	Configurable (parameter 1182: H43)	AI3
Analogue input 3 (Pb4)	AO regulation	Configurable (parameter 1183: H44)	AI4
Digital input 1 (DIL1)	0: Disabled; ±1 <i>Defrost</i> request; ±2Economy mode (reduced setpoint); ±4Door switch; ±5External alarm; ±7Stand-by; ±11 <i>Pressure switch</i> ; ±14: Light relay activation; ±15: <i>Ventilation fans</i> relay activation; ±18: Panic alarm; ±20: <i>Heating/Cooling mode</i> selection; ±21: Start/Stop thermal profiles program;	Configurable (parameter 1159: H11)	Door switch
Digital input 2 (DIL2)		Configurable (parameter 1160: H12)	External alarm
Digital input 3 (DIL3)		Configurable (parameter H13)	Pressure Switch
Digital input 4 (DIL4)		Configurable (parameter H14)	AUTO MODE
Digital input 5 (DIL5)		Configurable (parameter H15)	External Alarm
Digital input 6 (DIL6)		Configurable (parameter H16)	Defrost request
Digital	<i>Humidifier</i>	Fixed (not configurable)	<i>Humidifier</i>

Description	Meaning	Configuration	Default
output 1 (DO1)			
Digital output 2 (DO2)	<i>Heater</i>	Fixed (not configurable)	<i>Heater</i>
Digital output 3 (DO3)	<i>Dehumidifier</i> / Electric <i>defrost</i> relay	Configurable (parameter H23)	Dehumidifier
Digital output 4 (DO4)	<i>Compressor</i>	Fixed (not configurable)	<i>Compressor</i>
Digital output 5 (DO5)	<i>Evaporator fans</i>	Fixed (not configurable)	<i>Evaporator fans</i>
Digital output 6 (DO6)	Disabled / Light / Alarm* / <i>Ventilation fans</i>	Configurable (parameter 1168: H26)	Light
Analogue output (AO1)	cut-off	Fixed (not configurable)	Cut-off
Analogue output (AO2)	Disabled / Light / Alarm** / <i>Ventilation fans</i>	Configurable (parameter 1169: H27)	OC Alarm
Analogue output (AO3)	cut-off	Fixed (not configurable)	AO request 0-10V

*AlarmDO enabled @ ModBUS address 9090

**AlarmDO enabled @ ModBUS address 9091

5.7 Wiring Diagram 4 DIN model default settings

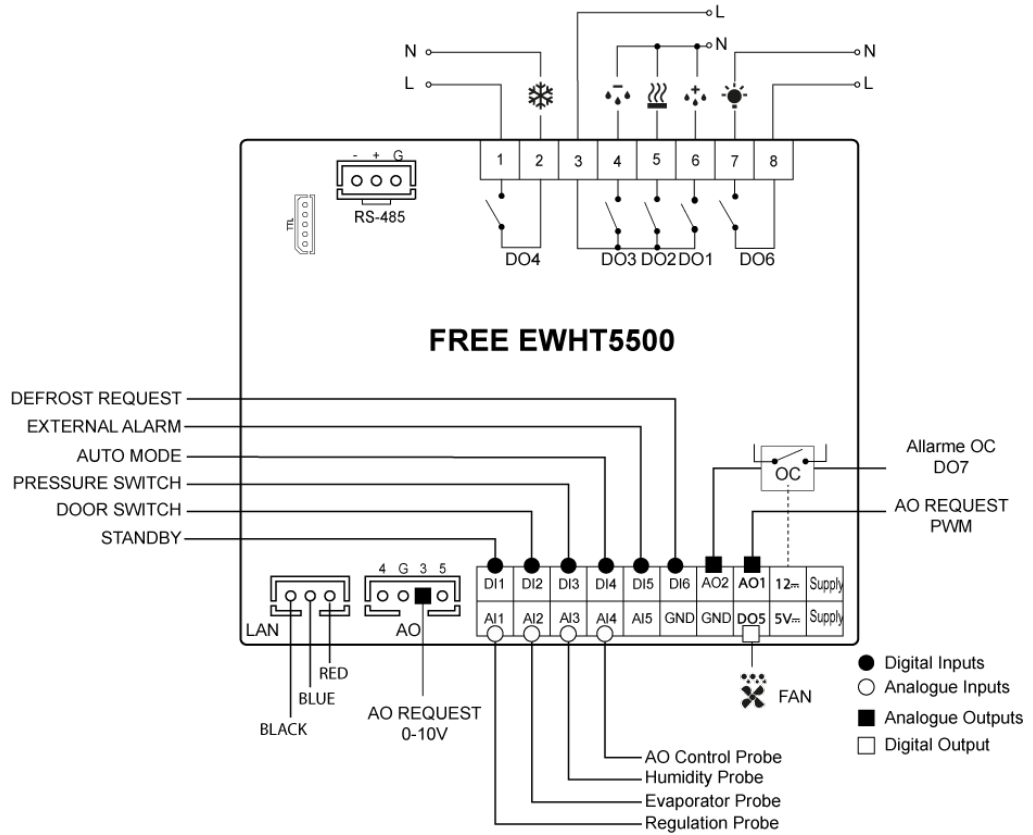

5.8 Wiring Diagram 32x74 panel mount model default settings

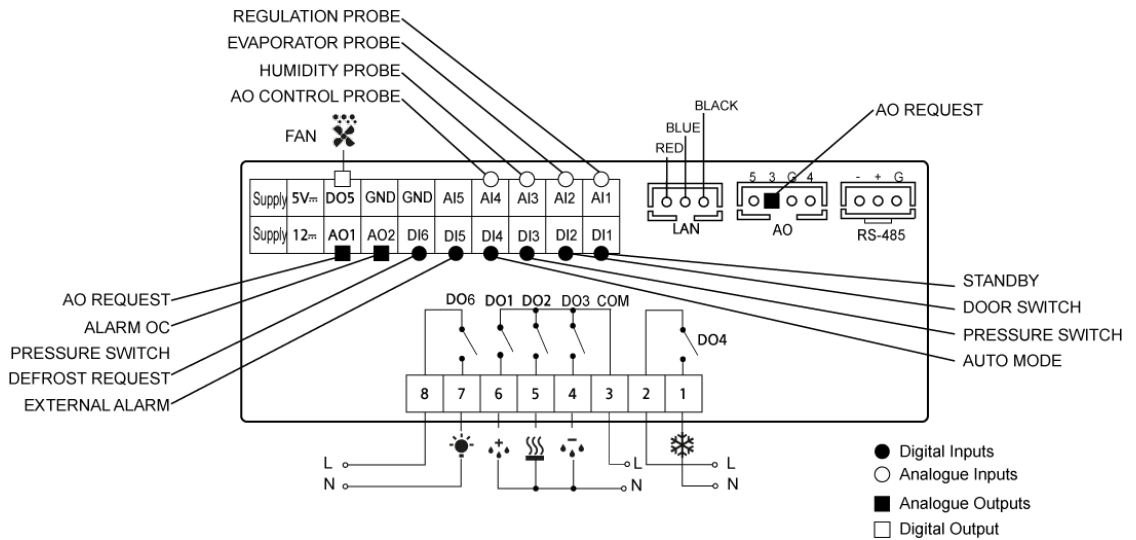

6 COMPRESSOR

The compressor is controlled by one of the device's *digital output*. It will be switched on or off depending on:

- the temperature measured by *probe Pb1*;
- *thermoregulation* settings;
- *defrost/dripping* settings.

6.1 Compressor configuration

For information about connecting the compressor to the device, refer to FREE Smart Installation Manual.

Compressor relay

The compressor is bound to relay **DO4**. Relay polarity is fixed.

6.2 Compressor operating conditions

The regulator is activated provided that:

- application state is ON;
- *alarm E1* is not active (cell temperature probe **Pb1** error);
- the time set in parameter **1014: ODO** has elapsed;
- a *defrost* cycle is not active (FREE mode excluded – see parameter **1028: DTY**).

The parameters of this regulator are:

- **SET1** setpoint, which can be chosen in a range defined by a minimum setpoint and a maximum setpoint (parameters **1004: LSE** e **1003: HSE**);
- differential (parameter **1002: DIF**).

Compressor regulation diagram

The diagram below indicates the compressor activation mode for cooling based on the **SET1** and **1002: DIF > 0** parameter.

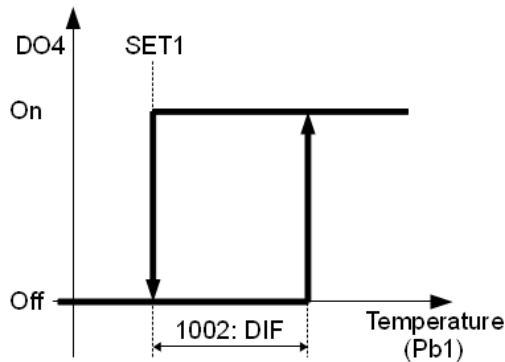

6.2.1 Compressor protection in the event of probe failure (duty cycle)

1009: ONT e 1010: OFT parameters

If the cold room probe **Pb1** fails (*alarm E1*), the output configured as compressor regulates in accordance with the times set in parameters **1009: ONT** and **1010: OFT**. The first time to consider is **1009: ONT**. If **1009: ONT > 0**, the protection programmed in parameters **1011: DON** / **1012: DOF** / **1013: DBI** must be respected (see *Compressor safety times*).

The table below lists the ways the compressor relay output can be managed:

1009: ONT	1010: OFT	DO4
0	0	Off
0	>0	Off
>0	0	On

1009: ONT	1010: OFT	DO4
>0	>0	Duty Cycle

Compressor duty cycle

If **1009: ONT** > 0 and **1010: OFT** > 0, the compressor regulator activates in operating cycle mode irrespective of the values read by the probes (cold room probe failure) and of requests from other utilities (duty cycle mode).

If the cold room probe is working properly, the duty cycle mode does not start as it does not have priority over normal compressor regulation settings.

Compressor duty cycle diagram

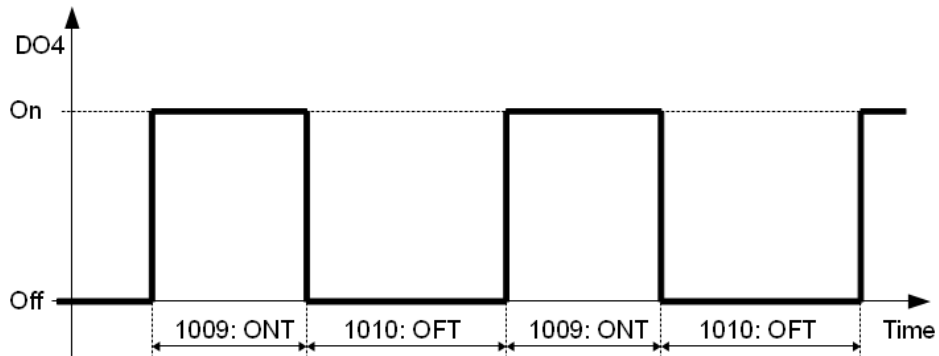

You are reminded that parameter **1014: ODO** inhibits the activation of all outputs commanding a relay for its entire duration (compressor, defrost, fans, etc.).

6.2.2 Compressor safety times

Compressor on-off operations must respect the safety times that you can set using the special parameters as described below. The compressor *LED* will flash to indicate when an activate compressor request has been received but a safety protection exists.

Off-on timing

A safety time (compressor on-off safety time) regulated by the parameter **1012: DOF** must be respected between a switch-off and switch-on of the same compressor.

This waiting time also occurs when the controller is powered on.

On-on timing

A safety time (compressor on-on safety time) regulated by the parameter **1013: DBI** must be respected between one switch-on and the next.

Delay

The safety time set in parameter **1011: DON** must elapse between a start-up request and actual start-up.

Times set with parameters **1011: DON** / **1012: DOF** / **1013: DBI**, if active, are not accumulative but parallel.

Diagram of compressor safety times

Compressor protection diagram with parameters **1011: DON** / **1012: DOF** / **1013: DBI** configured.

IN	Input state for compressor regulator
OUT	Output state for compressor regulator

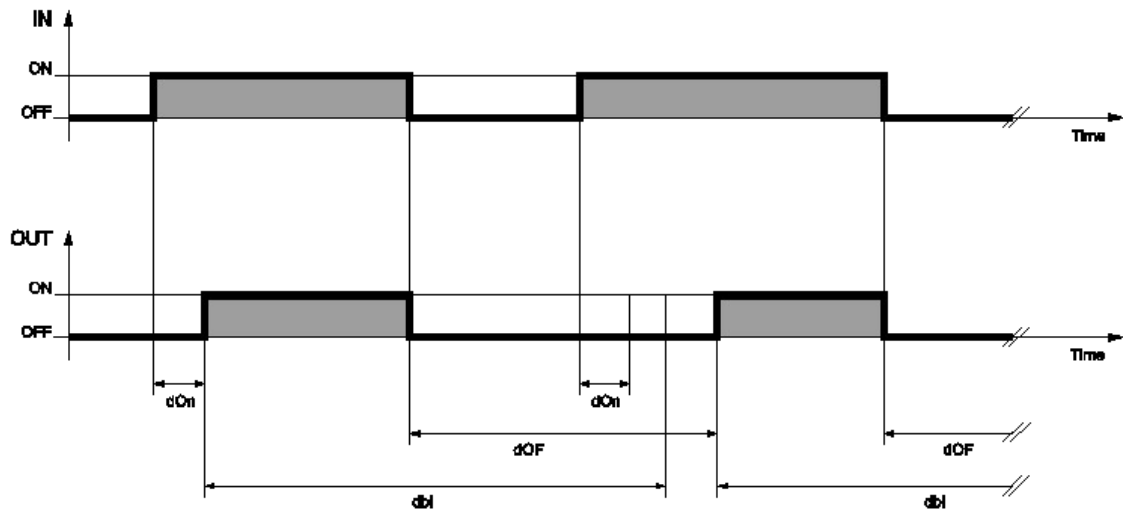

7 HEATING / COOLING

Thermoregulation *parameters* can be viewed and configured in the folders:

- *Compressor* menu (parameter **1002: DIF**);
- *Humidity* menu (parameter **1027: DB**);
- *Configuration* menu (parameter **1156: H07**, **1159: H11** e **1160: H12**).

Parameter **1156: H07** determines thermoregulation type and the set of parameters relevant to that process.

1156: H07	<i>Digital input</i>	Setpoint	<i>Relay</i>
Disabled	-	-	-
Neutral zone	-	SET1	Both DO2 and DO4
Cooling only	-	SET1	DO4
Heating only	-	SET2	DO2
From <i>digital input</i>	Cooling	SET1	DO4
	Heating	SET2	DO2

7.1 Heating

Set thermoregulation type to **1156: H07** = Heating only.

Heating relay		Comments
ON	OFF	
Temperature \leq SET2 - 1027: DB	Temperature $>$ SET2	Differential = 1027: DB always positive

Heating
regulation
diagram

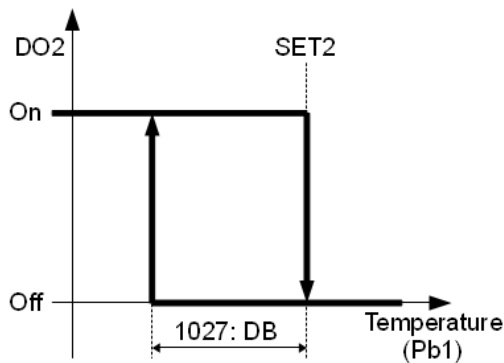

7.2 Cooling

Set thermoregulation type to **1156: H07** = Cooling only.

Compressor relay		Comments
ON	OFF	
Temperature \geq SET1 + 1002: DIF	Temperature $<$ SET1	Differential = 1002: DB always positive

Cooling regulation diagram

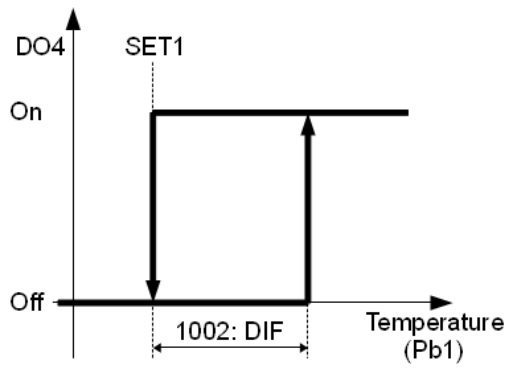

7.3 Neutral zone

Set thermoregulation type to **1156: H07** = Neutral zone.

Thermoregulation diagram (in neutral zone)

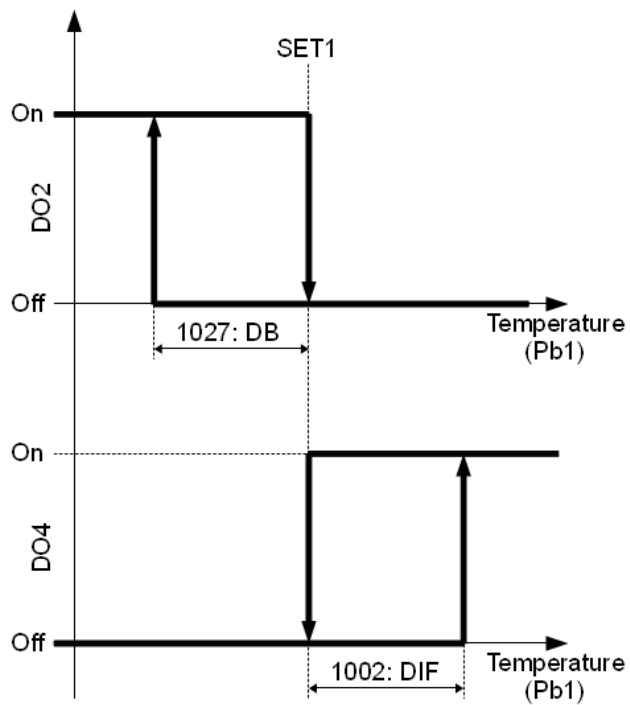

7.4 Heating/Cooling

Set thermoregulation type to **1156: H07** = From digital input. Set a *digital input* as heating/cooling: **1159: H11** / **1160: H12** = Heat/Cool (beware of polarity NO/NC).



These settings do not allow thermoregulation in neutral zone.

Diagram of thermoregulation with digital input mode selection

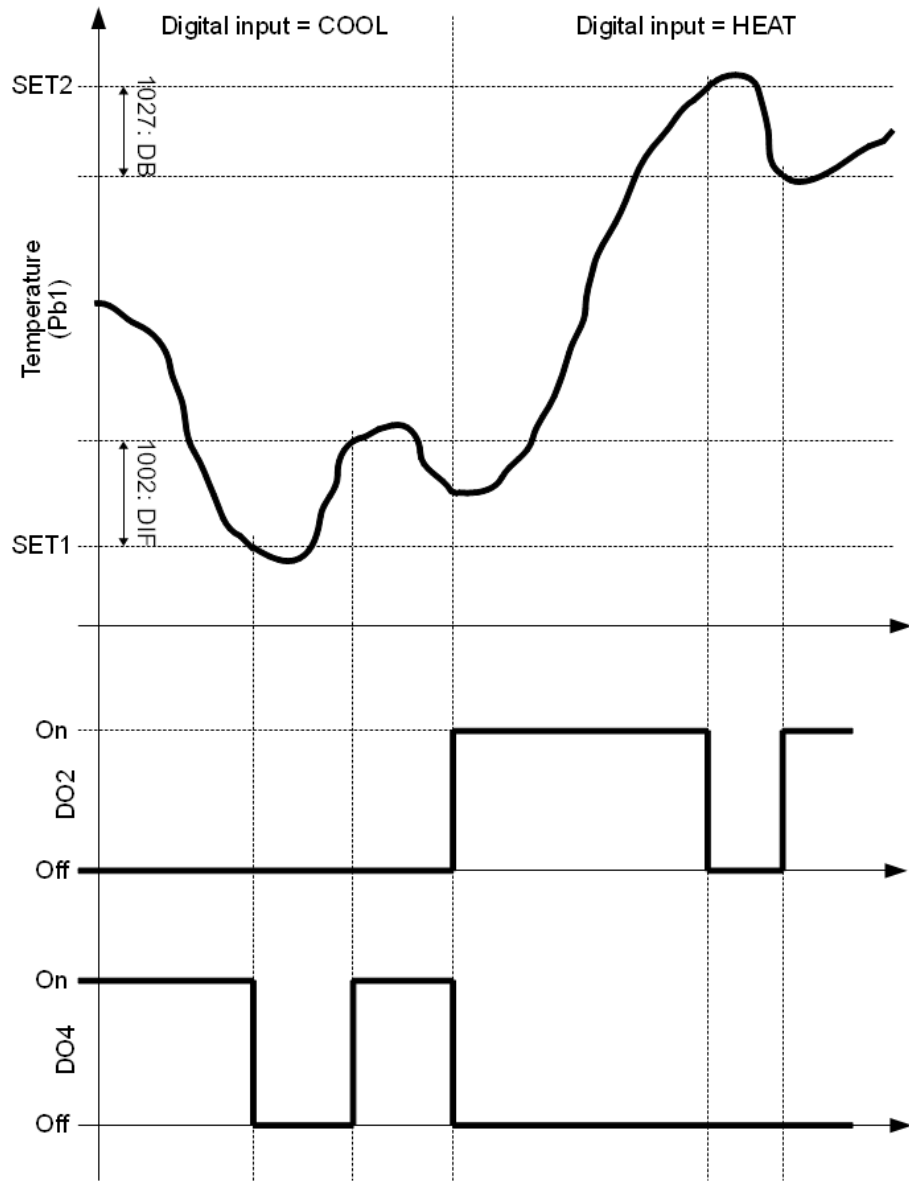

8 DEFROST

Defrost is used to stop ice from forming on the surface of the internal exchanger.

Defrost takes place basically (see *Defrost modes*) by heating up the internal exchanger using:

- electrical heaters;
- hot gas (hot gas solenoid valve);
- by simply stopping the *compressor* and hence the cooling cycle.

Dripping

On completion of defrost, given that there will be water on the internal exchanger, it is better not to start cooling right away as this would ruin the effect of the defrost by creating ice immediately.

The dripping interval is regulated via parameter **1044: DT**.

8.1 Defrost conditions and function

Defrosting is enabled if:

- the internal exchanger temperature is lower than the end defrost temperature set in parameter **1034: DST**;
- manual defrosting has not already been activated, in which case the request for automatic defrost will be canceled.

Defrost request

Defrost request can be made in the following ways:

Event	Condition
Application switch-on	If parameter 1036: DPO (defrost at switch on) is programmed accordingly
Time interval	If 1029: DIT > 0 each time the defrost time interval set in parameter 1029: DIT has elapsed
Clock (default)	If 1029: DIT = 0 and 1032: DCT = Clock and Clock alarm not active. Defrost is triggered at the times set in Defrost times menu

8.1.1 Automatic defrost

Automatic defrost start request

The defrost cycle is programmed to start at time intervals set in parameter **1029: DIT** > 0. Parameter **1032: DCT** determines how that time interval is counted.

To disable the automatic cycle, set **1029: DIT** = 0.

See automatic defrost with the Real Time Clock to run defrosts at given times.

1032: DCT	Description	Notes
Compressor up-time	Running time in hours of the compressor (DIGIFROST® method)	In this case, the counter runs only if the compressor is on. A new count starts when the defrost interval elapses and a new defrost cycle starts if conditions permit). Please note that compressor running time is counted independently from the internal exchanger temperature. If the internal exchanger probe is missing or faulty, the count continues for the time the compressor is on.
Unit up-time	Running time of the application (in ON state)	The defrost time interval is counted continuously when the application is ON and starts at each power-on. A defrost cycle starts when the defrost interval elapses (indicated by 1029: DIT) if conditions permit and the controller immediately starts counting a new defrost interval.
On compressor stop	On compressor stop	Each time the compressor stops, a defrost cycle is run according to the mode set in parameter 1028: DTY .
Clock	Con RTC (DEFAULT)	At the times set in Defrost times menu

Automatic defrost start conditions

Regardless of how the interval is counted, the following conditions apply:

- if the internal exchanger probe temperature is greater than **1034: DST**, defrost will not be permitted: a new interval will be counted and only at the end of this subsequent count will conditions be tested for the start of a defrost cycle.

8.1.2 Automatic defrost with Real Time Clock

Defrost times menu

Defrost time menu allows the definition of precise times in the day when an automatic defrost request should be considered by the application.

Times for working days are separated from times for the weekend (5+2 schema).



Both in the case of working days and in the case of weekend days, you can set up to 8 times in the day at which the automatic defrost request is issued.

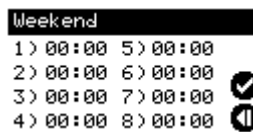

Note that a strict chronological sequence is not mandatory (you may enter the times in any order).



Defrost times exclusion

To not use any of the defrost times you can simply exclude them by increasing the hour value up to 24, which indicates that the parameter is deactivated.

8.1.3 Manual defrost

Manual defrost request

Pressing the manual defrost button will start the defrost cycle, which can also be started from *digital input*, if properly configured.

Procedures for the activation of this defrost cycle are the same as for external defrost.

The defrost interval will now be counted as described for automatic defrost (time **1189: DET** is not cleared, it continues).

Notification of a discarded defrost request

If conditions do not permit (internal exchanger temperature greater than the value set in parameter **1034: DST**), this will be signaled on the display (defrost icon blinks) and defrost will stop.

8.1.4 External or manual defrost

Time graphs for signals in each of the various function modes are presented below.

IN	Defrost request
OUT	Output state for defrost regulator. Note that (1034: DST) indicates defrost end due to temperature setpoint fulfillment.

Defrost request diagrams

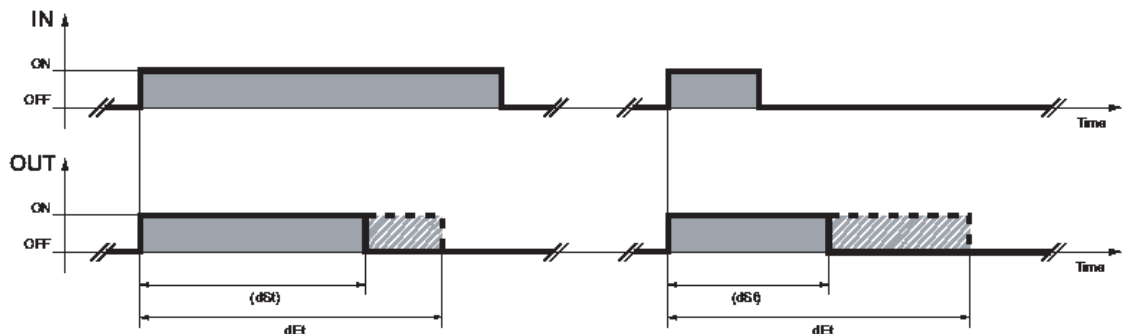

Defrost is activated on the rising edge. Hence, you can only activate a defrost, not stop one that is underway. Defrost and dripping currently underway and the defrost or dripping interval count cannot be suspended.

Defrost termination condition

8.2 Defrost modes

Defrost can be activated in four ways, as set in parameter **1028: DTY**.

Whatever the case, defrost is terminated when the following conditions hold:

1181: H42	Termination conditions
= Disabled (Evaporator probe not present)	After the timeout set in parameter 1189: DET (defrost timeout) occurred
≠ Disabled (evaporator probe present)	After reaching defrost end temperature set in parameter 1034: DST . If the temperature is not reached before the time set in parameter 1189: DET (defrost timeout) elapses, defrost is terminated.

8.2.1 Defrost with compressor stopped (DEFAULT)

The defrost cycle with the compressor stopped is configured by setting parameter **1028: DTY** = Electric.

Compressor stops for the duration of the defrost, and defrost relay does not exist (parameter **H23** ≠ Electric defrost).

On completion of defrost, the compressor relay stays off during the dripping time set in **1044: DT** if it is not equal to zero.

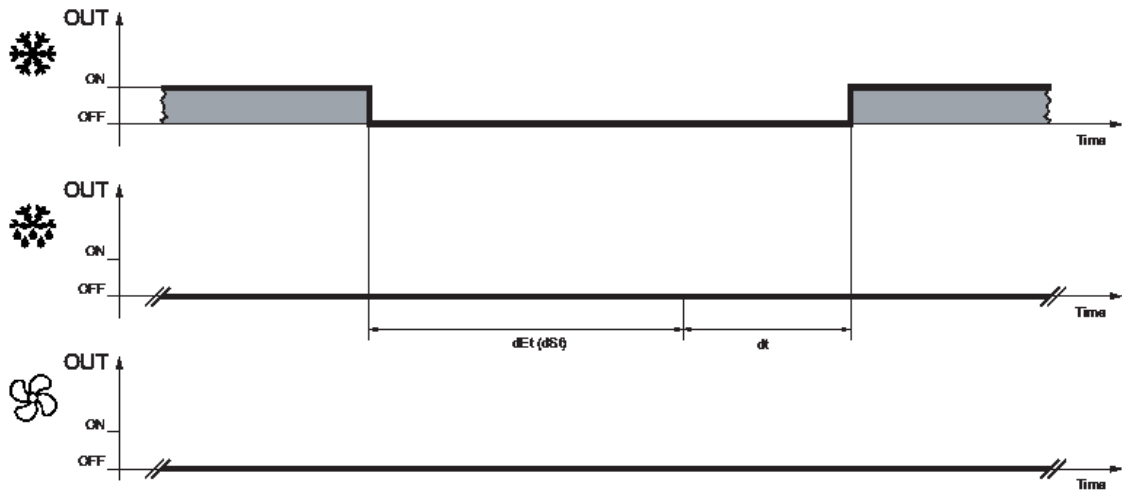

8.2.2 Defrost with electrical heaters

Defrost with electrical heaters is configured by setting **1028: DTY** = Electric and parameter **H23** = Electric defrost.

The *compressor* stops for the duration of the defrost cycle and the relay configured as defrost regulator output and that the electrical heaters are connected to activates.

On completion of defrost, the electrical heaters are switched off and the compressor remains off for the dripping time set in parameter **1044: DT**, if it is not equal to zero.

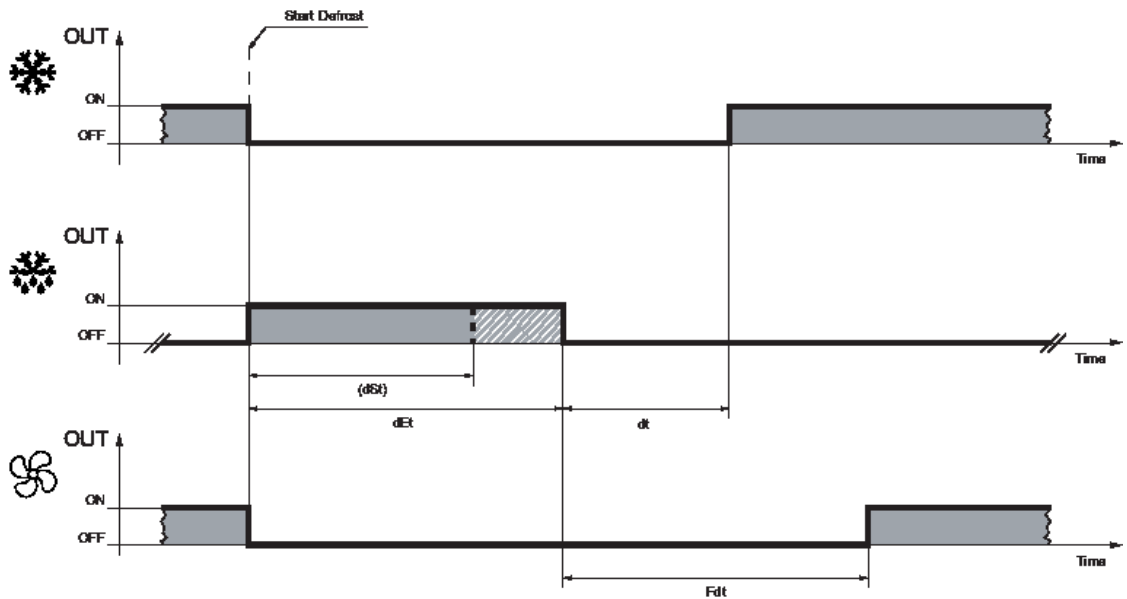

In the diagram, **1034: DST** marks defrost termination due to reaching of defrost stop temperature. If **1034: DST** intervenes before **1189: DET**, dripping (**1044: DT** and **1043: FDT**) aligns with **1034: DST**. If **1043: FDT** < **1044: DT** then will force **1043: FDT** = **1044: DT**.

During defrost, fans are off if parameter **1045: DFD** is set accordingly, otherwise they remain under the control of their own regulator.

8.2.3 Hot gas defrost

Hot gas defrost is configured by setting parameter **1028: DTY** = Cycle inversion and parameter **H23** = Electric defrost.

The *compressor* stays on for the entire duration of the defrost cycle and the relay configured as defrost regulator output and that the solenoid valve is connected to activates.

On completion of the defrost cycle, the solenoid valve relay is switched off and the dripping set in parameter **1044: DT** in enabled if not equal to zero. The compressor relay is once again controlled by the compressor regulator.



Parameters **1011: DON** / **1012: DOF** / **1013: DBI** (see *Compressor safety times*) have priority.

8.2.4 Defrost in FREE mode

Defrost cycle in FREE mode is configured by setting parameter **1028: DTY** = Free.

The *compressor* remains under the control of the compressor regulator for the duration of the defrost cycle and the relay configured as defrost and that the defrost heaters are connected to activates.

The heaters are switched off on completion of the defrost cycle. During dripping, the compressor continues to regulate.

8.2.5 Defrost regulator protection and constraints

Defrost timeout

If the defrost cycle does not terminate on reaching the end of defrost temperature set in parameter **1034: DST**, a maximum defrost time interval can be set in parameter **1189: DET**. If the defrost cycle terminates for timeout, an alarm can be activated by configuring parameter **1095: DAT** (see defrost timeout *alarm*).



Defrost can only be terminated manually by switching the controller on and off again using the ON/OFF function.

Moreover, some alarms may be excluded for a certain amount of time after the defrost cycle ends.

In the event of error **E1** (cold room probe **Pb1** error) defrost cycles will not be run.

9 EVAPORATOR FANS

9.1 Physical configuration

Evaporator fans relay

Evaporator fans are bound to *digital output* (relay) **DO5** (not configurable). Relay polarity is not configurable.

9.2 Operating conditions

Enabling evaporator fans regulation

Evaporator fans regulations is enabled if the following conditions hold:

- application is ON;
- has not been excluded during *defrost* by parameter **1045: DFD**;
- delay after defrost is not active (parameter **1043: FDT**);
- external alarm is not active while parameter **1096: RLO** requires fans are halted in such a condition;
- *pressure switch* alarm (caused by a number of pressure switch events greater than parameter **1115: PEN** in the time interval defined by parameter **1116: PEI**) is not active.

Evaporator fans relay inhibition

Relay bound to evaporator fans is inhibited if:

- door is open and parameter **1047: FOD** = Not active;
- time set in parameter **1014: ODO** has not elapsed yet.

9.3 Operating modes

In cooling, evaporator fans work as shown in this diagram.

	<i>Compressor</i> ON	<i>Compressor</i> OFF
Evaporator probe Pb2 not available (1181: H42 = Disabled)	ON	OFF
Evaporator probe Pb2 error	ON	OFF
Evaporator probe available (1181: H42 ≠ Disabled) and 1046: FCO = Not active (fans OFF if compressor OFF)	THERMOSTAT CONTROLLED	OFF
Evaporator probe available (1181: H42 ≠ Disable) e 1046: FCO = Thermostat controlled	THERMOSTAT CONTROLLED	THERMOSTAT CONTROLLED

Thermostat control of evaporator fans

Thermostat control of fans takes place at the values set in parameters **1040: FST** (block fans temperature) and **1042: FAD** (fans differential). Block fans temperature is absolute (real temperature value).

The fan regulator functions as indicated below.

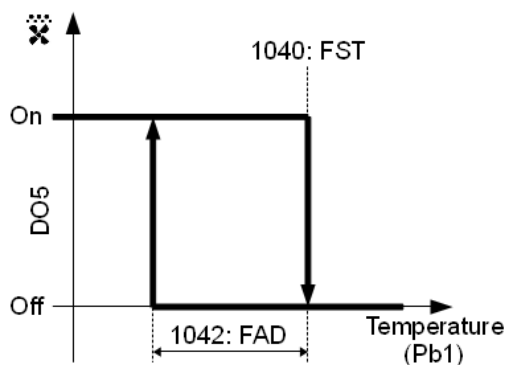

10 VENTILATION FANS

10.1 Physical configuration

Ventilation fans relay

To bind a *digital output* (relay) to ventilation fans either parameter **1168: H26** or **1169: H27**, found in menu Configuration, must be set accordingly.

Default configuration does not bind any relay to ventilation fans.

10.2 Operating conditions

Ventilation fans regulation is enabled if the following conditions hold:

- application is ON;
- ventilation is not switched off from *digital input*, if it has been configured as ventilation request by setting **1159: H11** / **1160: H12** = ± 15 ;
- ventilation fans relay is not disabled in the active *thermal profiles* program step (parameters **nP7** = No, where n is the active step).

10.3 Operating modes

Ventilation fans duty cycle

Ventilation fans are regulated in a duty cycle defined by parameters **1072: CON** and **1073: COF**, according to the rules reported in the following table.

1072: CON	1073: COF	relay
0	0	OFF
0	> 0	OFF
> 0	0	ON
> 0	> 0	Duty cycle

Regulation diagram

Ventilation fans operation is depicted in the following diagram.

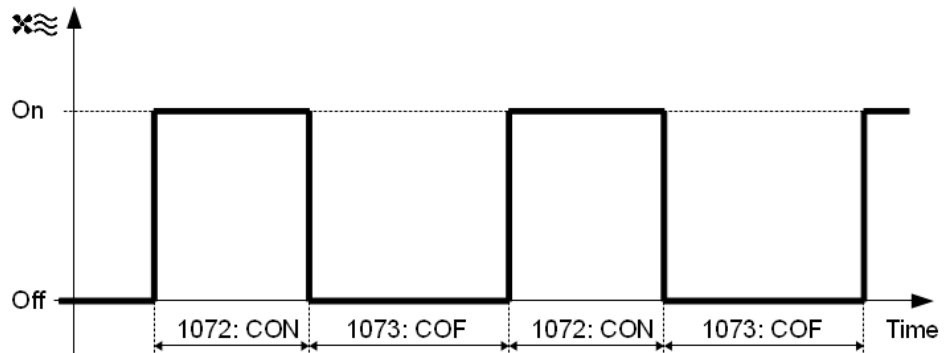

10.4 Programming

Parameters related to ventilation fans can be viewed and configured in the folders:

- the Ventilation fan folder in the installer menu (**1072: CON** and **1073: COF**);
- the Configuration folder in the installer menu (**1159: H11** / **1160: H12** and **1168: H26** / **1169: H27**).

11 ANALOG OUTPUT

The application manages one analog output as the output of a widely-parametric cut-off regulator.

As an example, the regulator may be used to regulate the fan unit on the outside of the heat exchanger that normally serves as a condenser. Various types of fan pilot modules can be connected depending on relative availability and the setting of *analog output* BIOS parameter (see FREE Smart Installation Manual, for details).

11.1 Physical configuration

The cut-off regulator is bound to *analog output AO1* (not configurable).

11.2 Operating conditions

The cut-off regulator associated to analog output is enabled if the following conditions hold:

- application is ON;
- regulator has been enabled by setting parameter **1051: F00** properly and **Pb4** probe is enabled, too (parameter **1183: H44** ≠ Disabled);
- either the cut-off regulator is independent of the *compressor* (**1067: F16** = Not active) or there is a switch on request coming from the *compressor*.

11.3 Operating modes

11.3.1 Start-up time

Start-up time

On each start-up of the cut-off regulator, the *analog output* is forced to its maximum value for the start-up time set in parameter **1054: F03**, after which the *analog output* is set to the value determined by the cut-off regulator.

11.3.2 Regulation on compressor request

Cut-off regulator can be configured to be independent of or dependent on the *compressor* state, by means of parameter **1067: F16**, which determines whether the cut-off regulator can be enabled if *compressor* is off.

11.3.3 Cut-off bypass time

Cut-off bypass time

By means of parameter **1069: F18** a cut-off bypass time can be set; during this period, if the regulator requests the cut-off, the *analog output* is forced to the value set with parameter **1057: F06** (minimum level).

11.3.4 Pre-ventilation

If the fan is activated by a compressor call (see paragraph *Regulation on compressor request*), the compressor ON signal is given only after the regulator has run for the minimum time given in parameter **1070: F19**.

Pre-ventilation is run to prevent the compressor from switching on at excessively high condensation temperatures.

11.3.5 Regulation

The diagrams below plot the *analog output* level as a function of the value read from the regulation probe and the cut-off regulator parameters.

The following diagram refers to cooling mode (**1052: F01** = Cool).

**Cut-off regulator
diagram in cooling
mode**

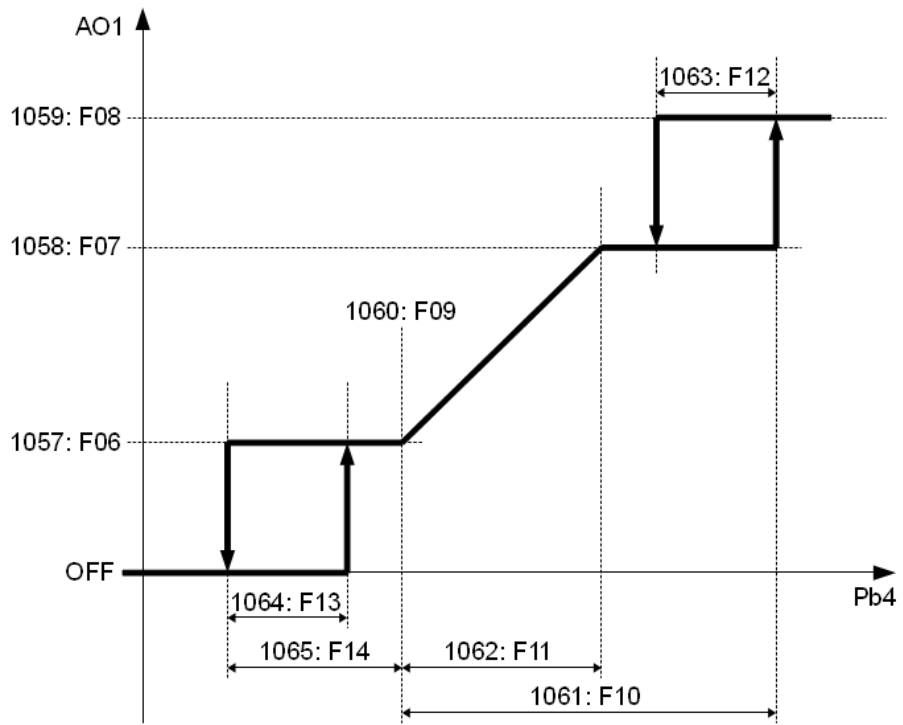

The following diagram refers to heating mode (1052: F01 = Heat).

**Cut-off regulator
diagram in heating
mode**

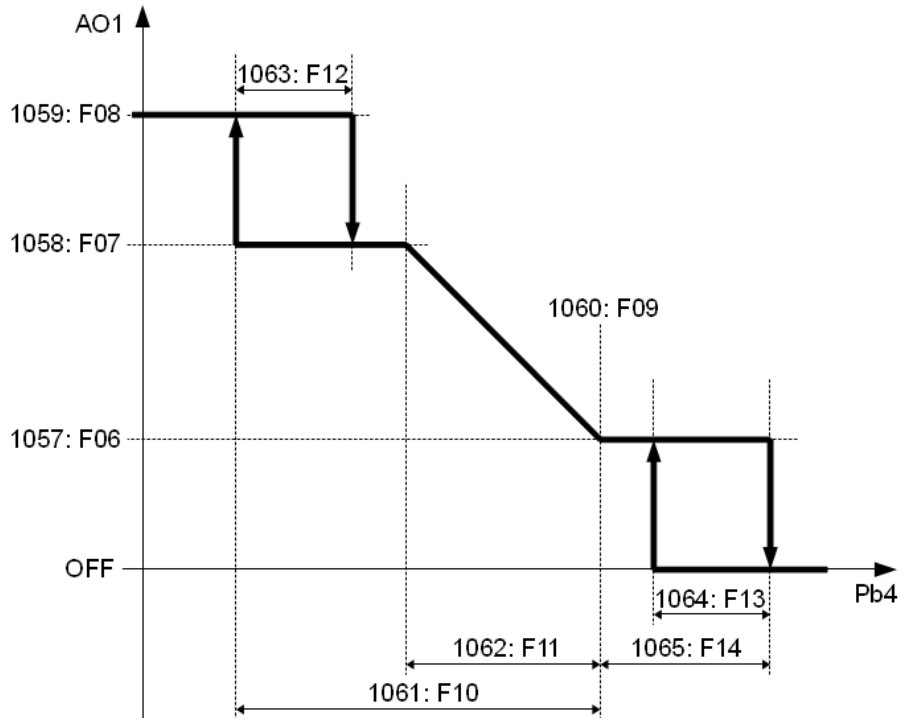

11.4 Programming

Cut-off regulator [parameters](#) can be viewed and configured in:

- the Analog output folder of the installer menu (1051: F00 ... 1071: F20);
- the Configuration folder of the installer menu (parameter 1183: H44).

12 PRESSURE SWITCH

The application performs diagnostic operations over a *digital input* associated via a configuration table. It is activated by setting paramters **1159: H11** / **1160: H12** = ±11.

12.1 Operating modes

Pressure switch event effect

If the pressure switch input is activated, power to the *compressor* is immediately cut off, the relative *alarm LED* lights up to indicate this visually and the alarm folder also displays the proper error message.

Pressure switch event count

Pressure switch diagnostics is configured by means of parameters **1115: PEN** and **1116: PEI**. The time **1116: PEI** is counted down starting at the first pressure switch event.

Pressure switch alarm

An alarm is generated only if the maximum number of events **1115: PEN** is reached before the time set in parameter **1116: PEI** elapsed; in this case, *compressor*, *evaporator fans* and *defrost* output are disabled and manual rearm of the alarm condition is required.

If the number of activations does not exceed the number set in parameter **1115: PEN** in the time interval set in parameter **1116: PEI** alarm condition is automatically rearmed.

If **1115: PEN** = 0 pressure switch diagnostics is inhibited.

12.1.1 Alarm reset

Once the controller is in alarm state, it must be powered off and then powered on again, or a reset request may be issued from either the active alarms menu or the functions menu.

13 HUMIDITY

13.1 Operating conditions

Relative humidity regulation (humidification and dehumidification) is enabled provided that:

- application is ON;
- regulation is enabled by setting **1154: H05** according to the following table and probe **Pb3** is enabled, too (parameter **1182: H43** ≠ Disabled);

1154: H05	Humidification	Dehumidification
Disabled	Disabled	Disabled
Neutral zone	Enabled	Enabled
Humidification	Enabled	Disabled
Dehumidification	Disabled	Enabled

- alarm **E3** is not active (humidity probe **Pb3** error);
- during *defrost*, regulation is not excluded by means of parameter **1024: DEH**.

13.2 Humidification

Application accomplishes the humidification task by means of an ON/OFF regulator with differential. The regulator output is bound to a relay, to which a humidifier has to be connected.

13.2.1 Physical configuration

The humidifier is bound to *digital output* (relay) **DO1** (not configurable). Relay polarity is not configurable.

For information about connecting the humidifier to the device, refer to FREE Smart Installation Manual.

13.2.2 Operating modes

The following diagram plots the state of the humidification relay as a function of the cell relative humidity. Differential **1021: DBH** is always positive.

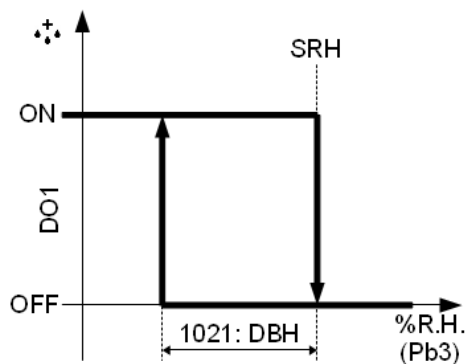

13.3 Dehumidification

Application accomplishes the dehumidification task by means of an ON/OFF regulator with differential. The regulator output is bound to one or more relays, depending on the selected *dehumidification mode*.

13.3.1 Dehumidification modes

Parameter **1158: H09** determines the selected dehumidification mode, according to the following schema.

Configurazione
regolazione
umidità relativa

Humidifier relay

Humidification
diagram

1158: H09	Description
Relay only	Dehumidification with dedicated relay
Relay and compressor	Dehumidification with both dedicated relay and compressor
No relay	Dehumidification with compressor and heating relay

13.3.2 Physical configuration

Dehumidification relay

Dehumidifier is bound to *digital output* (relay) **DO3**, if enabled with parameter **H22**. Default configuration enables the dehumidifier relay.

For information about *compressor relay* and *heating relay* configuration see the corresponding sections in this document.

13.3.3 Operating modes

Dehumidification diagram

The following diagram plots the state of dehumidification as a function of the cell relative humidity. Differential **1021: DBH** is always positive.

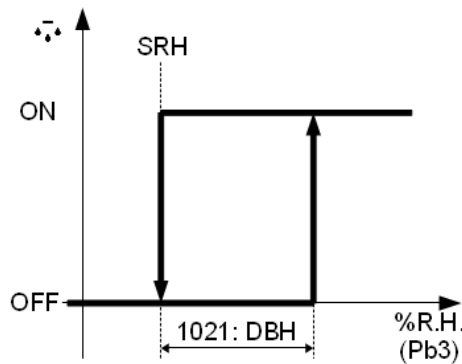

Dehumidification mode determines which relays are activated if dehumidification is on.

13.4 Programming

Parameters related to relative humidity regulation can be viewed and configured in:

- Humidity folder in the installer menu;
- Configuration folder in the installer menu (**1154: H05 / 1158: H09 / 1182: H43**).

Humidity setpoint can be set either from the *main view* or from a dedicated menu (setpoint menu).

14 THERMAL PROFILES

Application has an 8 step thermal profile. Each step is defined by a set of 10 parameters.

14.1 Programming

Thermal profiles menu

Parameters related to the thermal profiles program can be viewed and configured in the Thermal profiles menu, available in the programming menu folder **PrOF**

folder	Step 1	Step 2	...	Step8
PrOF	1P0	2P0	...	8P0
PrOF	1P1	2P1	...	8P1
PrOF	1P2	2P2	...	8P2
PrOF	1P3	2P3	...	8P3
PrOF	1P4	2P4	...	8P4
PrOF	1P5	2P5	...	8P5
PrOF	1P6	2P6	...	8P6
PrOF	1P7	2P7	...	8P7
PrOF	1P8	2P8	...	8P8
PrOF	1P9	2P9	...	8P9

14.2 Enabling the program

14.2.1 Shortcuts Enabling /disabling thermal profiles

Shortcuts

The temperature profiles can be activated by default from long press button **UP**

Displaying thermal profiles status program

The activation and displaying the status of the program is set by thermal profiles menu State, folder **rUn** where you will find the following resources:

folder rUn resources	Description
SCSt	Current step number
rSS	Start/Stop thermal profiles program
rrES	Reset thermal profiles program
rDiS	Disable thermal profiles program

14.3 Program control

14.3.1 Program START

In START mode, the main view displays the following depending on default static or dynamic view :

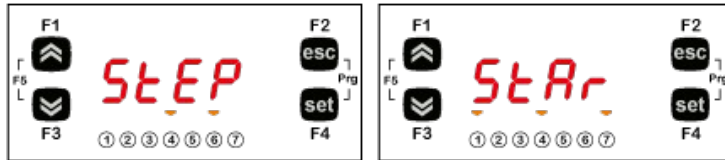

Step Nr

Start Step

Program can be started:

- Status menu folder **rUn**
- a *digital input* properly configured by setting parameter **1159: H11** / **1160: H12** = ±21 (toggle START/STOP);

14.3.2 Program RUN

In RUN mode, the main view displays the following depending on default static or dynamic view :

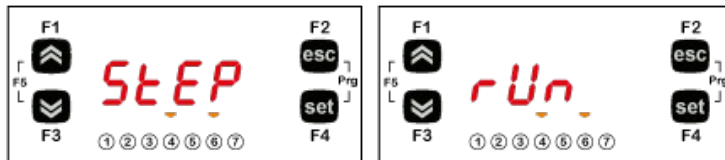

Step Nr.

Step running

14.3.3 Program STOP

Program can be stopped:

- Status menu folder **rUn**
- a *digital input* properly configured by setting parameter **1159: H11** / **1160: H12** = ±21 (toggle START/STOP);

**Thermal profiles
program step
parameters**

14.3.4 Program RESET

Program is reset from the thermal profiles program Status menu folder **rUn**

14.4 STEP behavior

The following table describes the parameters defining the application behavior when a thermal profiles program step is active.

Parameter	Description	Meaning														
nP0	Step activation delay	Step activation delay, in minutes, after a START event.														
nP1	Step duration	Determines the step duration, in minutes. If nP1 = 0 step stops when the temperature setpoint is reached (does not stop due to a timeout).														
nP2	<i>Relative humidity regulation</i> type	Determines the <i>relative humidity regulation</i> type while the step is active (overwrites parameter 1154: H05).														
nP3	<i>Thermoregulation</i> type	Determines the <i>thermoregulation</i> type while the step is active (overwrites parameter 1156: H07).														
nP4	Humidity setpoint	Determines the <i>relative humidity regulation</i> setpoint while the step is active (overwrites parameter SRH).														
nP5	Temperature setpoint 1	Determines <i>thermoregulation</i> setpoint while the step is active (overwrites SET1).														
nP6	Temperature setpoint 2	Determines <i>thermoregulation</i> setpoint while the step is active (overwrites SET2).														
nP7	Enable/Disable <i>ventilation fans</i> relay	Determines whether <i>ventilation fans</i> relay is enabled/disabled while the step is active. If no relay is configured for this purpose, this parameter has no effect.														
nP8	End step action	Determines the action taken at the end of the step and determines the active setpoint during the delay defined by parameter (n+1)P0 , if $\neq 0$.														
		<table border="1"> <thead> <tr> <th>NP8 available actions</th> <th>Description</th> </tr> </thead> <tbody> <tr> <td>End</td> <td>End of thermal profiles program.</td> </tr> <tr> <td>Next (continue) (*)</td> <td>Go to next step. Keep current setpoint during next step's activation delay.</td> </tr> <tr> <td>Next (wait) (*)</td> <td>Go to next step. Halt regulation, waiting for a new setpoint, during next step's activation delay.</td> </tr> <tr> <td>Loop</td> <td>Go back to the start of the step.</td> </tr> <tr> <td>Go to step</td> <td>Return to step number nP9.</td> </tr> <tr> <td>Everlasting</td> <td>Unlimited duration.</td> </tr> </tbody> </table>	NP8 available actions	Description	End	End of thermal profiles program.	Next (continue) (*)	Go to next step. Keep current setpoint during next step's activation delay.	Next (wait) (*)	Go to next step. Halt regulation, waiting for a new setpoint, during next step's activation delay.	Loop	Go back to the start of the step.	Go to step	Return to step number nP9 .	Everlasting	Unlimited duration.
		NP8 available actions	Description													
		End	End of thermal profiles program.													
		Next (continue) (*)	Go to next step. Keep current setpoint during next step's activation delay.													
		Next (wait) (*)	Go to next step. Halt regulation, waiting for a new setpoint, during next step's activation delay.													
		Loop	Go back to the start of the step.													
Go to step	Return to step number nP9 .															
Everlasting	Unlimited duration.															
(*) value has no effect during STEP 8 (there are no further steps)																
nP9	Jump back target	Determines the jump back target if nP8 = Go to step.														

At the end of “End step” the system returns to manual control (i.e. Profiles are disabled)

14.5 Example

The following example discuss a simple 3-step thermal profiles program where both thermoregulation and relative humidity regulation are in neutral zone.

Step	Delay (nP0)	Duration (nP1)	Regulation type (nP2 / nP3)	Humidity setpoint (nP4)	Temperature setpoint (nP5)
Step1	Delay 1	Endurance 1	NZ / NZ	Humidity	Setpoint temperature A
Step2	/	Endurance 2	NZ / NZ	Setpoint humidity	Setpoint temperature B
Step3	/	Endurance 3	NZ / NZ	Setpoint humidity	Setpoint temperature A

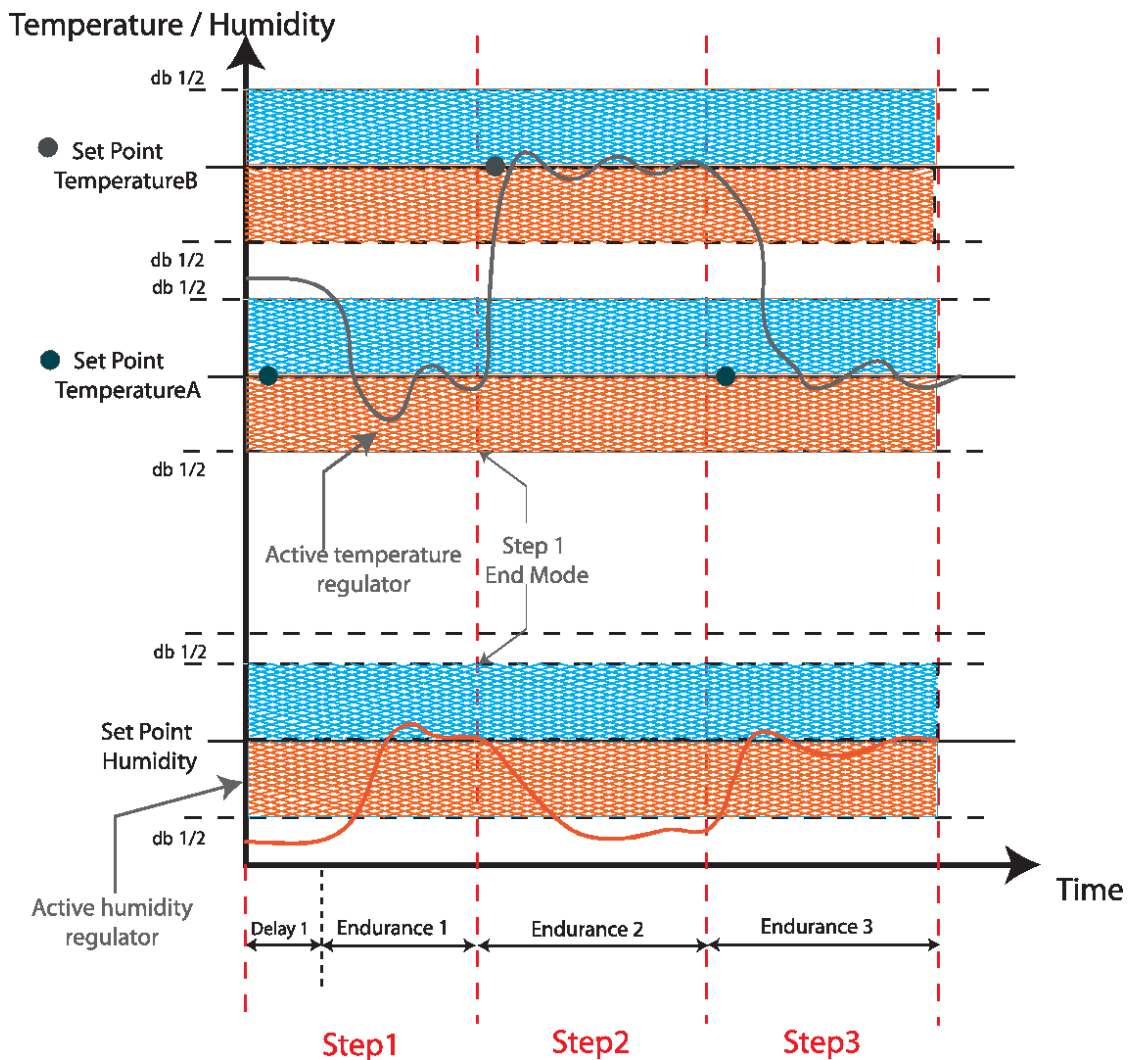

15 ALARMS AND DIAGNOSTICS

The application is able to perform complete diagnostics of the system and report any operating trouble with specific alarms.

Alarm condition display

Alarms are always reported by::

- alarm *icon* shown on the display;
- FREE Smart programmable controller's alarm *LED*.

15.1 Probe error

Probe errors are caused by:

- measured values are outside the nominal range;
- probe faulty / short-circuited / open.

Active probe errors are displayed in the active alarm menu.

The table below lists probe errors.

Error code	Probe error	Effect
E1	Probe Pb1 error (cell temperature)	<ul style="list-style-type: none"> • <i>compressor duty cycle</i> according to parameters 1009: ONT and 1010: OFT • heating regulator disabled • high/low temperature diagnostics is disabled • currently active step of the <i>thermal profiles program</i> is forced to stop, if it is configured with unlimited duration (termination after reaching temperature setpoint)
E2	Probe Pb2 error (evaporator temperature)	<ul style="list-style-type: none"> • <i>defrost</i> termination due to timeout, not because temperature setpoint has been reached • <i>evaporator fans</i> regulation depends upon <i>compressor</i> state
E3	Probe Pb3 error (cell relative humidity)	<ul style="list-style-type: none"> • <i>relative humidity regulation</i> disabled • high/low humidity diagnostics is disabled
E4	Probe Pb4 error (<i>cut-off regulator</i> feedback)	<ul style="list-style-type: none"> • <i>analog output</i> bound to the <i>cut-off regulator</i> is regulator according to parameter 1071: F20 (either off or forced to maximum level)

15.2 Alarms

The following table lists all the application alarms, error probes excluded.

Error code	Alarm	Cause	Effect	Solution
08	High temperature	See <i>High/Low alarms</i>	No effect on regulation (warning only)	Wait for the temperature value read by probe Pb1 (cell temperature) to fall below 1081: HAL
09	Low temperature	See <i>High/Low alarms</i>	No effect on regulation (warning only)	Wait for the temperature value read by probe Pb1 (cell temperature) to rise above

Error code	Alarm	Cause	Effect	Solution
				1082: LAL
19	High humidity	See High/Low alarms	No effect on regulation (warning only)	Wait for the humidity value read by probe Pb3 (cell humidity) to fall below 1089: HHA
20	Low humidity	See High/Low alarms	No effect on regulation (warning only)	Wait for the humidity value read by probe Pb3 (cell humidity) to fall below 1090: LHA
01	External alarm	Due to activation of the digital input configured as alarm (1159: H11 / 1160: H12 = ±5)	Blocks regulators in accordance with parameter 1096: RLO	Regulators resume normal operation upon subsequent deactivation of the digital input
13	Defrost timeout	Interruption of defrost due to timeout instead of reaching defrost end temperature (read from probe Pb2 , evaporator temperature)	No effect on regulation (warning only)	Manual alarm reset required
03	Door open alarm	After the delay 1086: TDO since door opening	No effect on regulation (warning only)	Alarm remains active until the door is closed
02	Panic alarm	Due to activation of the digital input configured as panic alarm (1159: H11 / 1160: H12 = ±18)	No effect on regulation (warning only)	Alarm remains active until subsequent deactivation of the digital input
04	Pressure switch alarm	See Pressure switch		
RTC	Clock error	Real Time Clock error (see FREE Smart Installation Manual)	Clock-related functions are disabled: automatic defrost on time events; thermal profiles program start-up time	See FREE Smart Installation Manual

15.3 High/Low (temperature / relative humidity) alarms

High/Low alarms indicate that user-defined temperature/relative humidity thresholds have been crossed.

15.3.1 High/Low temperature alarms configuration

High/Low temperature alarms refer to values read by probe **Pb1** (cell temperature).

Temperature thresholds are set with parameters **1081: HAL** and **1082: LAL**. Parameter **1079: ATT** determines whether they represent absolute temperature values (**1079: ATT** = Absolute) or values relative to current temperature setpoint (**1079: ATT** = Relative).

High/Low temperature thresholds

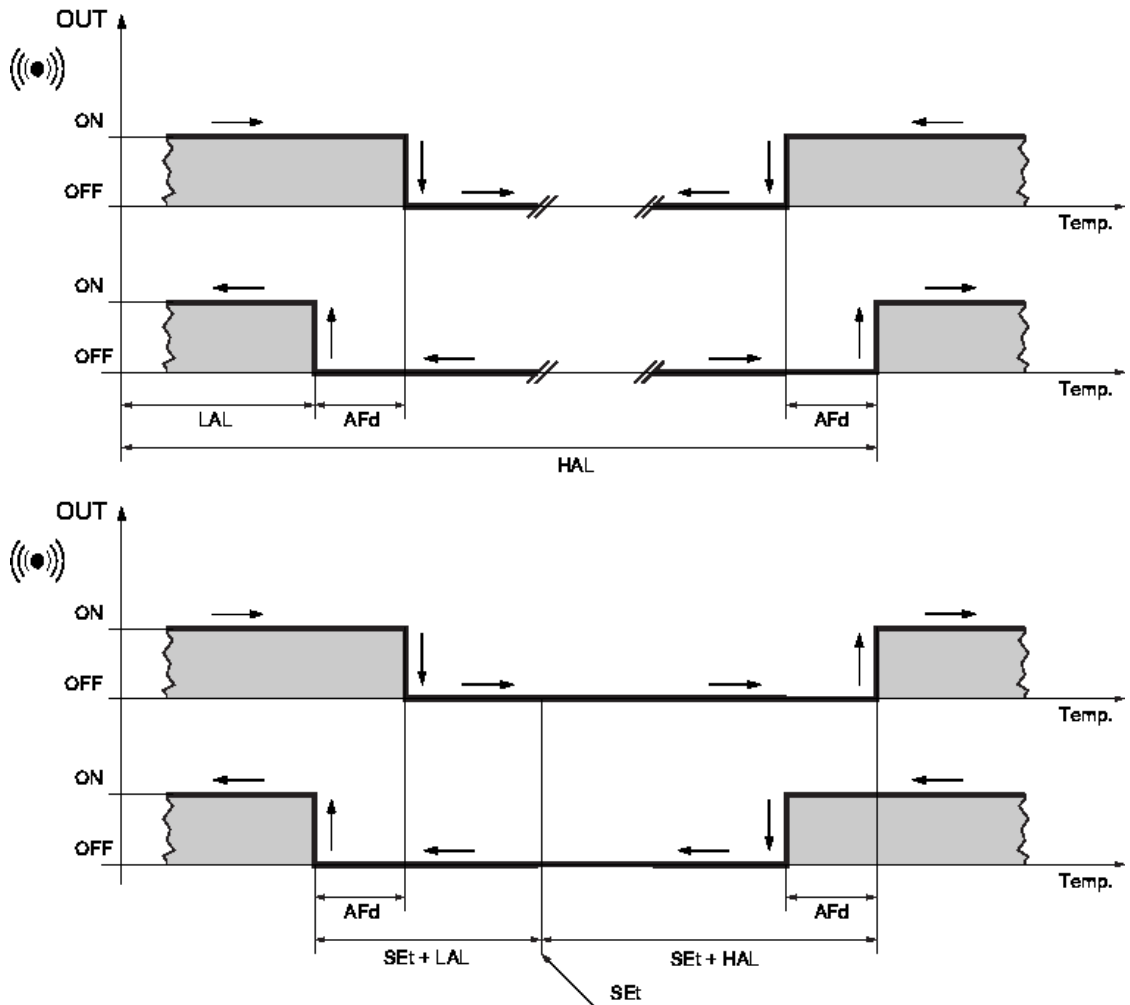

To generate an alarm when the value falls below the setpoint when **1079: ATT** = Relative, a negative value must be entered for **1082: LAL**.

Power-on exclusion

Using parameter **1083: PAO** you can set an exclusion time for high/low temperature alarms following the device power-on.

Alarm exclusion after defrost

Using parameter **1084: DAO** you can set an exclusion time for high/low temperature alarms following defrost termination.

Alarm exclusion after door closure

Using parameter **1085: OAO** you can set an exclusion time for high/low temperature alarms following the door closure. During the time intervals defined by parameters 1083: PAO / 1084: DAO / 1085: OAO, the regulator is disabled and any temperature alarms are not signaled.

Alarm signal delay

Using parameter **1087: TAO** you can set a delay for the signaling of the alarm when it occurs.

15.3.2 High/Low humidity alarms configuration

High/Low humidity alarms refer to values read by probe **Pb3** (cell humidity).

High/Low humidity thresholds

Humidity thresholds are set with parameters **1089: HHA** and **1090: LHA**. Parameter **1088: ATH** determines whether they represent absolute humidity values (**1088: ATH** = Absolute) or values relative to current humidity setpoint (**1088: ATH** = Relative).



To generate an alarm when the value falls below the setpoint when **1088: ATH** = Relative, a negative value must be entered for **1090: LHA**.

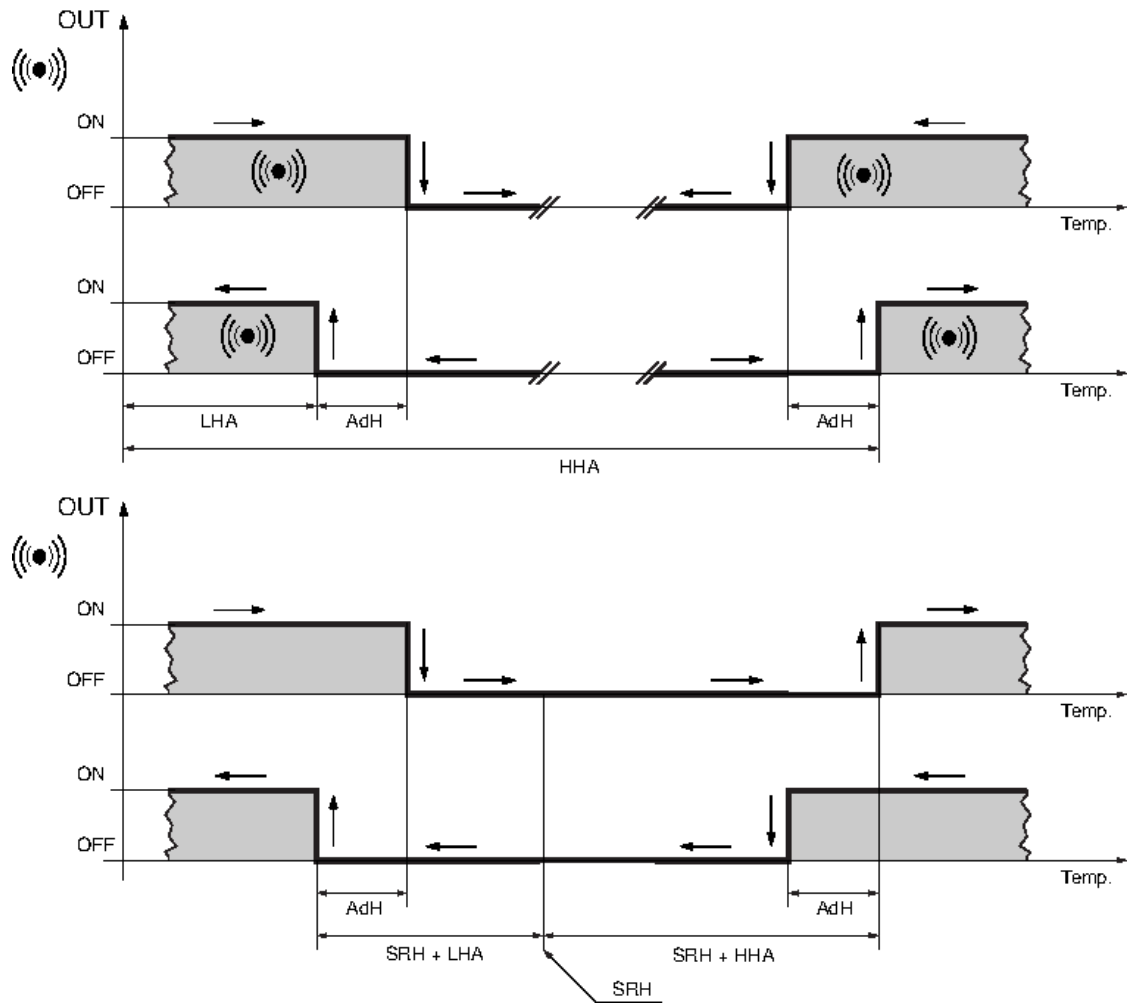

Power-on exclusion

Using parameter **1093: PAH** you can set an exclusion time for high/low relative humidity alarms following the device power-on.

Alarm exclusion after door closure

Using parameter **1094: OAH** you can set an exclusion time for high/low relative humidity alarms following the door closure.

During the time intervals defined by parameters **1093: PAH** / **1094: OAH**, the regulator is disabled and any relative humidity alarms are not signaled.

Alarm signal delay

Using parameter **1092: AOH** you can set a delay for the signaling of the alarm when it occurs.

16 PARAMETERS

Parameters can be set to fully configure the application.

They can be modified with:

- the application [user interface](#);
- a Personal Computer and the FREE Studio Device software tool.

The following sections analyze each parameter, divided into categories (folders), in detail. The parameters are listed below in tables.

16.1.1 Parameter menu

The following table indicates the visibility of the application parameters, grouped by folders/menus, depending on access rights granted (user or installer).

Some parameters are visible only if installer access rights have been granted: please refer to the parameter reference table at the end of the chapter for this information.

Following table shows all parameters grouped in folders, included in **PAr menu described below**

	Folder	Display name	Read/Write
	Update Clock	rtC	Read/Write
	Defrost Time	dF1	Read/Write
	Thermal profiles	PrOF	Read/Write
	Compressor	CPr	Read/Write
	Humidity	HUd	Read/Write
	Defrost	dEF	Read/Write
	Evaporator fan	FAn	Read/Write
	Analog output	AO	Read/Write
	Ventilation fan	ACF	Read/Write
	Alarms	Alr	Read/Write
	Light and digital input	Lit	Read/Write
	Configuration	CnF	Read/Write
	Release	rEL	Read only

16.2 rtC = Update Clock

rtHr Update hour

Hours settings (0-23 format)

rtMi Update minutes

Minutes settings (0-59 format)

rtSE Update seconds

Seconds settings (0-59 format)

16.3 dF1 = Defrost time

See Defrost folder – Real Time Clock defrost

16.4 dF1 = Thermal profiles

See thermal profile folder

16.5 Compressor

1002: DIF Differential

Compressor relay activation differential; the compressor stops on reaching the Setpoint value (as indicated by the adjustment probe) and restarts at a temperature value equal to the Setpoint plus the value of the differential.

1003: HSE Setpoint MAX

Maximum value that can be assigned to the setpoint.

1004: LSE Setpoint MIN

Minimum value that can be assigned to the setpoint.

NOTE: The two sets are interdependent: **1003: HSE** (maximum setpoint) can not be less than **1004: LSE** (minimum setpoint), and viceversa.

1005: OSP Economy setpoint

Temperature value to be added algebraically to the setpoint if reduced set enabled (Economy function). It can be activated with a key stroke, by a function or a digital input configured for this purpose.

1006: HC Mode

Compressor operating mode. If **1006: HC** = Heat, compressor integrates the heating regulator and the application can not do cooling anymore (parameter **1156: H07** should be set accordingly).

1009: ONT Duty cycle time on

Actuation time (in minutes) of the compressor due to a probe failure (see [compressor duty cycle](#)).

1010: OFT Duty cycle time off

Shutdown time (in minutes) of the compressor due to a probe failure (see [compressor duty cycle](#)).

1011: DON On start delay

The parameter indicates that a protection is active on the relay actuation of the compressor. The time indicated must elapse between the request and the actual activation of the compressor relay.

1012: DOF Stop-start delay

The parameter indicates that a protection is active on the relay actuation of the compressor. The time indicated must elapse between the request and the actual activation of the compressor relay

1013: DBI Start-start delay

Delay between activations; the delay time indicated must elapse between two consecutive activations of the compressor.

1014: ODO **Power-on delay**
Delay in activating outputs after the controller is switched on or after a power failure.
If **1014: ODO** = 0, not active.

16.6 Humidity

1021: DBH **Differential**
Relative humidity regulation differential.

1022: HSH **Setpoint MAX**
Maximum value that can be assigned to the humidity setpoint.

1023: LSH **Setpoint MIN**
Minimum value that can be assigned to the humidity setpoint.

1024: DEH **While defrosting**
Relative humidity regulation while defrosting. If **1024: DEH** = Not active, relative humidity regulation is not active during defrost; if **1024: DEH** = Active, relative humidity regulation is active during defrost.

1025: OdEH **Economy Offset Dehumidification**
Value to add with sign for dehumidification in economy mode

1026: OHUM **Economy Offset Umidification**
Value to add with sign for humidification in economy mode

1027: dB **Heating band**
Heating regulation band.

16.7 Defrost

1028: DTY **Type**
Defrost mode.
If **1028: DTY** = Electric, electric defrost (OFF Cycle defrost, that is compressor not running during defrost). NOTE: electrical defrost + air defrost, in the case of fans in parallel with the defrost output relay).
If **1028: DTY** = Cycle inversion, cycle inversion defrost (hot gas, or compressor running during defrost).
If **1028: DTY** = Free, defrost with Free mode (independent of compressor status).

1029: DIT **Time interval**
Time interval between the start of two subsequent defrosting cycles. Times are expressed in hours.
This parameter is used in automatic defrosts at fixed intervals. If **1029: DIT** = 0 there is no automatic defrost: defrost is never executed.

1032: DCT **Counting type**
Selects the count mode for the defrost interval.
If **1032: DCT** = Compressor up-time (DIGIFROST® method), counter is incremented only with the compressor on. Compressor running time is counted separately from the evaporator probe (count active if evaporator probe missing or faulty).
If **1032: DCT** = Unit up-time, defrost count is always active when the application is on.
If **1032: DCT** = On compressor stop, a defrost cycle is run at each compressor stop, depending on the parameter **1028: DTY**.
If **1032: DCT** = Clock, a defrost cycle is run at each time set in the defrost times menu.

1033: DOH **Power-on exclusion**
Defrost exclusion time after switching on application.

1189: DET **Timeout**
Defrost timeout. Determines the maximum duration of defrosting, in minutes.

1034: DST **Stop temperature**
Defrost stop temperature measured by defrost probe.

1036: DPO **At power-on**
Determines if a defrost cycle has to run when the application is switched on.
If **1036: DPO** = Not required, defrost not run at start-up.
If **1036: DPO** = Required, defrost run at start-up.

16.8 Evaporator fans

1040: FST **Stop temperature**
Fan stop temperature; if the evaporator probe reads a higher value than the set value, the fans are stopped. The value can be positive or negative.
Temperatures are expressed in absolute values.

1042: FAD **Differential**
Fan activation differential, relative to stop temperature given in parameter **1040: FST**.

1043: FDT **Delay time**
Fan activation delay after a defrosting cycle.

1044: DT **Drainage time**
After a defrost cycle, the fans and compressor remain off for the time set in this parameter.

1045: DFD **While defrosting**
Allows exclusion of the evaporator fans to be selected or not selected during defrosting.
If **1045: DFD** = Not active, fans are off during defrost.
If **1045: DFD** = Active, evaporator fans regulation is active during defrost.

1046: FCO **If compressor off**
Selects or not fan deactivation at compressor OFF.
If **1045: FCO** = Off, evaporator fans are off if compressor is off.
If **1045: FCO** = Thermostat controlled, evaporator fans are independent of compressor state.
Value **1045: FCO** = Duty cycle is not used.

1047: FOD **If door open**
Selects fan deactivation when the door is opened and fan restart when the door is shut (if they were running).
If **1047: FOD** = Not active, fans are off if door is open.
If **1047: FOD** = Active, evaporator fans regulation is active when the door is open.

1048: FDC **Post-ventilation**
Fan switch off delay after compressor stop, in minutes. If **1048: FDC** = 0 this function is excluded.

16.9 Analog output

1051: F00 **Configuration**
Enable/Disable cut-off regulator.
If **1051: F00** = Disabled, cut-off regulator is disabled and all its parameters are ignored by the application.
If **1051: F00** = Enabled, cut-off regulator is enabled and its parameters should be properly configured along with the

	regulation probe Pb4 .
1052: F01	Mode Cut-off regulator operating mode (heat/cool).
1054: F03	Start-up time Start-up time during which the analog output bound to the cut-off regulator is forced to maximum level.
1057: F06	Minimum level Minimum level (percentage) of analog output bound to the cut-off regulator.
1058: F07	Medium level Medium level (percentage) of analog output bound to the cut-off regulator.
1059: F08	Maximum level Maximum level (percentage) of analog output bound to the cut-off regulator.
1060: F09	Setpoint Cut-off regulator setpoint. When setpoint is reached, the analog output bound to the cut-off regulator is forced to minimum level given in parameter 1057: F06 .
1061: F10	Maximum level differential Differential, relative to the setpoint given in parameter 1060: F09 , at which the cut-off regulator forces the analog output to the maximum level.
1062: F11	Proportional band Cut-off regulator proportional band.
1063: F12	Maximum level hysteresis Maximum-Medium level (of the analog output bound to the cut-off regulator) hysteresis width.
1064: F13	Cut-off hysteresis Cut-off hysteresis width.
1065: F14	Cut-off differential Differential, relative to the setpoint given in parameter 1060: F09 , at which the cut-off regulator forces the analog output to off (cut-off).
1066: F15	While defrosting Determines whether cut-off regulator is enabled or disabled during defrost. If 1066: F15 = Not active, cut-off regulator is disabled during defrost. If 1066: F15 = Active, cut-off regulator is enabled during defrost.
1067: F16	If compressor off Enable/Disabled cut-off regulator when compressor is off. If 1067: F16 = Not active, cut-off regulator is disabled when compressor is off. If 1067: F16 = Active, cut-off regulator is enabled when compressor is off.
1068: F17	After defrost exclusion After defrost exclusion time of the cut-off regulator.
1069: F18	Cut-off bypass time Cut-off bypass time.
1070: F19	Pre-ventilation Pre-ventilation time.
1071: F20	If probe KO

State of the analog output bound to the cut-off regulator in case of regulation probe error.

If **1071: F20** = Not active, analog output is forced to off (0%).

If **1071: F20** = Active, analog output is forced to maximum level (100%).

16.10 Ventilation fans

1072: CON **Duty cycle time on**

Ventilation fans duty cycle time on.

1073: COF **Duty cycle time off**

Ventilation fans duty cycle time off.

16.11 Alarms

1079: ATT **Temperature alarm value type**

Mode of parameters **1081: HAL** and **1082: LAL**, understood as absolute temperature values or as values relative to the setpoint.

If **1079: ATT** = Absolute, parameters **1081: HAL** and **1082: HAL** give absolute temperature values.

If **1079: ATT** = Relative, parameters **1081: HAL** and **1082: HAL** give values relative to the setpoint.

1080: AFD **Temperature differential**

High/Low temperature alarm differential (with respect to respective thresholds).

1081: HAL **High temperature threshold**

High temperature alarm threshold.

Temperature upper limit (distance from setpoint or absolute value in relation to **1079: ATT**) which, when crossed, triggers an alarm signal.

1082: LAL **Low temperature threshold**

Low temperature alarm threshold.

Temperature lower limit (distance from setpoint or absolute value in relation to **1079: ATT**) which, when crossed, triggers an alarm signal.

1083: PAO **Power-on exclusion**

High/Low temperature alarms exclusion time following a power-on.

1084: DAO **After defrost exclusion**

High/Low temperature alarms exclusion time after defrost.

1085: OAO **After door closure exclusion**

High/Low temperature alarms exclusion time after door closure.

1086: TDO **Door open delay**

Time out after alarm signal following digital input deactivation (door open).

1087: TAO **Temperature alarm delay**

Delay signaling high/low temperature alarms.

1088: ATH **Humidity alarms value type**

Mode of parameters **1089: HHA** and **1090: LHA**, understood as absolute relative humidity values or as values relative to the setpoint.

If **1088: ATH** = Absolute, parameters **1089: HHA** and **1090: LHA** gives absolute relative humidity values.

If **1088: ATH** = Relative, parameters **1089: HHA** and **1090: LHA** gives values relative to the setpoint.

1089: HHA **High humidity threshold**

	High humidity alarm threshold.
	Humidity upper limit (distance from setpoint or absolute value in relation to 1088: ATH) which, when crossed, triggers an alarm signal.
1090: LHA	Low humidity threshold
	Low humidity alarm threshold.
	Humidity lower limit (distance from setpoint or absolute value in relation to 1088: ATH) which, when crossed, triggers an alarm signal.
1091: ADH	Relative humidity differential
	High/Low humidity alarm differential (with respect to respective thresholds).
1092: AOH	Relative humidity alarm delay
	Delay signaling high/low alarms.
1093: PAH	Power-on exclusion
	High/Low humidity alarms exclusion time following a power-on.
1094: OAH	After door closure exclusion
	High/Low humidity alarms exclusion time after door closure.
1095: DAT	On defrost timeout
	Alarm signaling end of defrost due to timeout.
	If 1095: DAT = No alarm, no alarm is signaled on defrost timeout.
	If 1095: DAT = Alarm, alarm is signaled on defrost timeout.
1096: RLO	Lock on external alarm
	Regulators locked when external alarm is active:
	If 1096: RLO = None, external alarm does not block any resource.
	If 1096: RLO = Comp/Defrost, external alarm blocks compressor and defrost.
	If 1096: RLO = Comp/Defrost/Fan, external alarm blocks compressor, defrost, and evaporator fans.
	 16.12 Light and digital inputs
1104: DSD	Light when door open
	Enables light relay from door switch.
	If 1104: DSD = Off, opening the door does not turn on the light.
	If 1104: DSD = On, opening the door turns on the light (when off).
1105: DLT	Light off delay
	Delay switching off relay configured as light after door is closed.
	Valid if 1104: DSD is set to switch on light when door opens.
1106: OFL	Light off from key
	Disable light relay from key, even if light off delay 1105: DLT is active.
1115: PEN	Pressure switch limit
	Number of pressure switch events allowed.
1116: PEI	Pressure switch time
	Pressure switch event count time interval.

16.13 Configuration

1154: H05 Relative humidity regulation

If **1154: H05** = Disabled, relative humidity regulation disabled.

If **1154: H05** = Neutral zone, relative humidity regulation enabled in neutral zone (both humidification and dehumidification).

If **1154: H05** = Humidification only, relative humidity regulation enabled in humidification only.

If **1154: H05** = Dehumidification only, relative humidity regulation enabled in dehumidification only.

1156: H07 Thermoregulation

If **1156: H07** = Disabled, thermoregulation disabled.

If **1156: H07** = Neutral zone, thermoregulation enabled in neutral zone (both heating and cooling).

If **1156: H07** = Heating only, thermoregulation enabled in heating only.

If **1156: H07** = Cooling only, thermoregulation enabled in cooling only.

If **1156: H07** = From digital input, thermoregulation enabled with heat/cool mode selection from digital input.

1158: H09 Dehumidification type

If **1158: H09** = Relay only, dehumidification with dedicated relay.

If **1158: H09** = Relay and compressor, dehumidification with dedicated relay and compressor.

If **1158: H09** = No relay, dehumidification with compressor and heating device.

1159: H11 Digital input 1

Digital input 1 configuration.

See digital input configuration table.

1160: H12 Digital input 2

Digital input 2 configuration.

See digital input configuration table.

H13 Digital input 3

Digital input 3 configuration.

See digital input configuration table.

H14 Digital input 4

Digital input 4 configuration.

See digital input configuration table.

H15 Digital input 5

Digital input 5 configuration.

See digital input configuration table.

H16 Digital input 6

Digital input 6 configuration.

See digital input configuration table.

H23 Digital output 3

Digital output 3 configuration.

See digital output configuration table.

1168: H26	<p>Digital output 6</p> <p>Digital output 6 configuration.</p> <p>See digital output configuration table.</p>
1169: H27	<p>Digital output 7</p> <p>Digital output 7 configuration.</p> <p>See digital output configuration table.</p>
1180: H41	<p>Probe 1</p> <p>Probe Pb1 (cell temperature) configuration.</p> <p>See analog input configuration table.</p>
1181: H42	<p>Probe 2</p> <p>Probe Pb2 (evaporator temperature) configuration.</p> <p>See analog input configuration table.</p>
1182: H43	<p>Probe 3</p> <p>Probe Pb3 (cell humidity) configuration.</p> <p>See analog input configuration table.</p>
1183: H44	<p>Probe 4</p> <p>Probe Pb4 (cut-off regulator feedback) configuration.</p> <p>See analog input configuration table.</p>
FdSS	<p>Visualizzazione fissa grandezza principale a display</p> <p>Refer to Keys Table</p>
FdMO	<p>Abilita Visualizzazione dinamica grandezza principale a display</p> <p>0 = disabled (static / fixed view); 1 = enabled (dynamic / rotation view)</p>
	<p>Keys</p>
UPSF	<p>UP Function Key single press</p> <p>Refer to Keys Table associated Functions</p>
UPLF	<p>UP Function Key long press</p> <p>Refer to Keys Table associated Functions</p>
DWFS	<p>DOWN Function Key single press</p> <p>Refer to Keys Table associated Functions</p>
DWLF	<p>DOWN Function Key long press</p> <p>Refer to Keys Table associated Functions</p>
ESCF	<p>ESC Function Key long press</p> <p>Refer to Keys Table associated Functions</p>
SETF	<p>set Function Key long press</p> <p>Refer to Keys Table associated Functions</p>

16.14 Programming reference

The following tables report a summary description of the whole set of application parameters discussed in preceding paragraphs, along with information about the range of allowed values, default value, and unit of measurement. Moreover, necessary information to read and write them by means of a fieldbus communication protocol is also recorded.

16.14.1 Parameter tables

The table below lists all application configuration parameters stored in the device's permanent memory, and their visibilities.

Column meaning:

Column	Meaning
Address	Only when accessing the parameter through fieldbus communication protocols (with software tools not included in Eliwell FREE Studio). Parameter address for access through communication protocol (either Modbus, CANopen or Modbus TCP). Modbus and Modbus TCP addresses are HOLDING REGISTERS to be access through 3H / 10H commands
ID	Parameter unique identifier (ID), as it is displayed in the application menu or in the regulators' description in this document
Label	Parameter label, as it is displayed in the application menu
Values Device Type	Values List of parameter enumerative values Device Type Parameter data type: that determines the range of the allowed values for the parameter (to be further refined by the limits shown in Min and Max columns) and the need to apply a conversion, only when accessing the parameter through fieldbus communication protocols (with software tools not included in Eliwell FREE Studio) , because the value is signed number. For example, in case you access to a 16-bit integer parameter by means of a communication protocol, you have to apply the following conversion: <ul style="list-style-type: none"> if the value read is between 0 and 32767, the result is equal to the value read (zero and positive values); if the value read is between 32.768 and 65.535, the result is the value read - 65.536 (negative values).
Min	Minimum value you can assign to the parameter
Max	Maximum value you can assign to the parameter
Default	Default parameter value (set by FREE Studio Device when downloading the application to the FREE Smart programmable controller).
U.M.	Unit of measurement.
Format	FREE Studio Device display format for Default Value /Min/Max - XXX.Y display of whole number with decimal point Only when accessing the parameter through fieldbus communication protocols (with software tools not included in Eliwell FREE Studio). If XXX.Y , the value read by means of a fieldbus communication protocol has to be divide by 10 (value/10) in order to convert it to the scale in which Min/Max/Default values are given in the table, according to the U.M. column. Example: parameters HSE = 50.0. Column will include XXX.Y <ul style="list-style-type: none"> value shown on the display/read by FREE Studio Device is 50.0; value read by means of a fieldbus communication protocol is 500 → 500/10 = 50.0.
Description	Parameter description.
Client Table only	
Read only	enables/disables editing of Status variables.

16.14.2 Modbus table

The table below lists all application configuration parameters including Modbus addresses

Address	ID	Label	Values Device Type	Default	Min	Max	Unit	Format	Description
16384	_1001_Set1	SEt1	Signed 16-bit INT	0	LSE	HSE	°C	XXX.Y	Cooling/Neutral zone setpoint
16385	SEt2	SEt2	Signed 16-bit INT	0	LSE	HSE	°C	XXX.Y	Heating setpoint
16386	_1002_diF	diF	Signed 16-bit INT	20	0	300	°C	XXX.Y	Differential
16387	_1003_HSE	HSE	Signed 16-bit INT	500	LSE	1100	°C	XXX.Y	Maximum setpoint value
16388	_1004_LSE	LSE	Signed 16-bit INT	-500	-500	HSE	°C	XXX.Y	Minimum setpoint value
16389	_1005_OSP	OSP	Signed 16-bit INT	0	-300	300	°C	XXX.Y	Economy offset (added to P1001_Set)
16390	_1006_HC	HC	0=Heating; 1=Cooling USINT	1					Compressor mode (HEAT/COOL)
16393	_1009_Ont	Ont	Unsigned 16-bit UINT	10	0	255	min		Compressor time on, when probe is broken
16394	_1010_OFt	OFt	Unsigned 16-bit UINT	10	0	255	min		Compressor time off, when probe is broken
16395	_1011_dOn	dOn	Unsigned 16-bit UINT	10	0	1000	s		Switching-on time delay
16396	_1012_dOF	dOF	Unsigned 16-bit UINT	0	0	1000	s		Switching-off time delay
16397	_1013_dbi	dbi	Unsigned 16-bit UINT	2	0	255	min		Time delay between consecutive switching-ons
16398	_1014_OdO	OdO	Unsigned 16-bit UINT	0	0	255	min		Power-on time delay
16403	_1019_SRH	SRH	Signed 16-bit INT	500	LSH	HSH	%R.H.	XXX.Y	Relative humidity setpoint
16405	_1021_dbH	dbH	Signed 16-bit INT	50	0	500	%R.H.	XXX.Y	Relative humidity differential
16406	_1022_HSH	HSH	Signed 16-bit INT	1000	LSH	1000	%R.H.	XXX.Y	Maximum relative humidity setpoint value
16407	_1023_LSH	LSH	Signed 16-bit INT	0	0	HSH	%R.H.	XXX.Y	Minimum relative humidity setpoint value
16408	_1024_dEH	dEH	0=Not active; 1=Active BOOL	0					Relative humidity regulation status when defrosting
16409	_1025_ODEH	ODEH	Signed 16-bit INT	0	-300	300	%R.H.	XXX.Y	Dehumidifier Economy offset
16410	_1026_OHUM	OHUM	Signed 16-bit INT	0	-300	300	%R.H.	XXX.Y	Humidifier Economy offset

Address	ID	Label	Values Device Type	Default	Min	Max	Unit	Format	Description
16411	_1027_db	db	Signed 16-bit INT	20	0	500	°C	XXX.Y	Heating band
16412	_1028_dtY	dtY	0 =Electric; 1=Cycle inversion; 2=Free USINT	0					Defrost type
16413	_1029_dit	dit	Signed 16-bit INT	6	0	255	h		Defrost time interval
16416	_1032_dCt	dCt	0=Compressor uptime; 1=Unit uptime; 2=On compressor stop; 3 = 3=Real time clock USINT	3					Defrost time interval counting type
16417	_1033_dOH	dOH	Unsigned 16-bit UINT	0	0	59	min		Power-on exclusion of defrost
16418	_1034_dSt	dSt	Signed 16-bit INT	60	-3020	14720	°C	XXX.Y	Defrost stop temperature
16420	_1036_dPO	dPO	0=Not required; 1=Required BOOL	0					Defrost at power-on
16424	_1040_FSt	FSt	Signed 16-bit INT	60	-3020	14720	°C	XXX.Y	Fan stop temperature
16426	_1042_FAd	FAd	Signed 16-bit INT	10	10	500	°C	XXX.Y	Fan differential
16427	_1043_Fdt	Fdt	Unsigned 16-bit UINT	0	0	255	min		Fan delay time
16428	_1044_dt	dt	Unsigned 16-bit UINT	0	0	255	min		Drainage time
16429	_1045_dFd	dFd	0=Not active; 1=Active BOOL	1					Defrost fan disable
16430	_1046_FCO	FCO	0=Off; 1=Thermostat controlled; 2=Duty cycle USINT	1					Fan when compressor OFF
16431	_1047_Fod	Fod	0=Not active; 1=Active BOOL	1					Fan when door open
16432	_1048_FdC	FdC	Unsigned 8-bit UINT	0	0	99	min		Fan delay when compressor OFF
16435	_1051_F00	F00	0=Disable; 1=Enable BOOL	0					A.O. configuration
16436	_1052_F01	F01	0=Heating; 1=Cooling USINT	1					A.O. mode
16438	_1054_F03	F03	Unsigned 16-bit UINT	10	0	60	s		A.O. start up time
16441	_1057_F06	F06	Signed 16-bit INT	30	0	100	%		A.O. minimum level
16442	_1058_F07	F07	Signed 16-bit INT	95	0	100	%		A.O. medium level
16443	_1059_F08	F08	Signed 16-bit INT	100	0	100	%		A.O. maximum level
16444	_1060_F09	F09	Signed 16-bit INT	300	-500	999		XXX.Y	A.O. setpoint
16445	_1061_F10	F10	Signed 16-bit INT	100	0	999		XXX.Y	A.O. maximum level differential

Address	ID	Label	Values Device Type	Default	Min	Max	Unit	Format	Description
16446	_1062_F11	F11	Signed 16-bit INT	70	0	255		XXX.Y	A.O. proportional band
16447	_1063_F12	F12	Signed 16-bit INT	20	0	255		XXX.Y	A.O. maximum level hysteresis width
16448	_1064_F13	F13	Signed 16-bit INT	20	0	255		XXX.Y	A.O. cut-off hysteresis width
16449	_1065_F14	F14	Signed 16-bit INT	30	0	255		XXX.Y	A.O. cut-off differential
16450	_1066_F15	F15	0=Not active; 1=Active BOOL	1					A.O. when defrosting
16451	_1067_F16	F16	0=Not active; 1=Active BOOL	1					A.O. when compressor OFF
16452	_1068_F17	F17	Unsigned 8-bit UINT	0	0	59	min		A.O. delay after defrosting
16453	_1069_F18	F18	Unsigned 16-bit UINT	0	0	255	s		A.O. bypass time
16454	_1070_F19	F19	Unsigned 16-bit UINT	0	0	255	s		A.O. pre-ventilation
16455	_1071_F20	F20	0=Not active; 1=Active BOOL	1					A.O. when probe broken
16456	_1072_COn	COn	Unsigned 16-bit UINT	1	0	255	min		Ventilation fan time ON
16457	_1073_COF	COF	Unsigned 16-bit UINT	0	0	255	min		Ventilation fan time OFF
16463	_1079_Att	Att	0=Absolute; 1=Relative USINT	1					Temperature alarm value type (absolute/relative)
16464	_1080_AFd	AFd	Signed 16-bit INT	10	10	500	°C	XXX.Y	Temperature alarm differential
16465	_1081_HAL	HAL	Signed 16-bit INT	500	_1082_LAL		°C	XXX.Y	High temperature alarm value
16466	_1082_LAL	LAL	Signed 16-bit INT	-500		_1081_HAL	°C	XXX.Y	Low temperature alarm value
16467	_1083_PAO	PAO	Unsigned 16-bit UINT	3	0	10	h		Power-on exclusion of temperature alarm
16468	_1084_dAO	dAO	Unsigned 16-bit UINT	60	0	999	min		After defrost exclusion of temperature alarm
16469	_1085_OAO	OAO	Unsigned 16-bit UINT	1	0	10	h		After door closure exclusion of temperature alarm
16470	_1086_tdO	tdO	Unsigned 16-bit UINT	10	0	255	min		Door open exclusion
16471	_1087_tAO	tAO	Unsigned 16-bit UINT	0	0	255	min		Temperature alarm delay
16472	_1088_Ath	Ath	0=Absolute; 1=Relative USINT	1					Humidity alarm value type (absolute/relative)
16473	_1089_HHA	HHA	Signed 16-bit INT	500	_1090_LHA		%R.H.	XXX.Y	High humidity alarm value

Address	ID	Label	Values Device Type	Default	Min	Max	Unit	Format	Description
16474	_1090_LHA	LHA	Signed 16-bit INT	-500		_1089_HHA	%R.H.	XXX.Y	Low humidity alarm value
16475	_1091_AdH	AdH	Signed 16-bit INT	20	10	500	%R.H.	XXX.Y	Humidity alarm differential
16476	_1092_AOH	AOH	Unsigned 16-bit UINT	0	0	255	min		Humidity alarm delay
16477	_1093_PAO	PAO	Unsigned 16-bit UINT	3	0	10	h		Power-on exclusion of humidity alarm
16478	_1094_OAH	OAH	Unsigned 16-bit UINT	1	0	10	h		After door closure exclusion of humidity alarm
16479	_1095_dAt	dAt	0=No alarm; 1=Alarm BOOL	0					Alarm on defrost timeout
16480	_1096_rLO	rLO	0=None; 1=Compressor and defrost; 2=Compressor, defrost, and fans USINT	0					Regulators locked by external alarm
16488	_1104_dSd	dSd	Boolean BOOL	1					Light ON when door open
16489	_1105_dLt	dLt	Unsigned 8-bit UINT	0	0	31	min		Light OFF delay
16490	_1106_OFI	OFL	Boolean BOOL	1					Light OFF from D.I.
16499	_1115_PEn	PEn	Unsigned 16-bit UINT	15	0	15			Number of pressure switch errors allowed
16500	_1116_PeI	PEI	Unsigned 16-bit UINT	99	1	99	min		Pressure switch error count interval
16542	_1154_H05	H05	0=Disabled; 1=Neutral zone; 2=Humidification only; 3 = 3=Dehumidification only USINT	1					Relative humidity regulation type
16544	_1156_H07	H07	0=Disabled; 1=Neutral zone; 2=Heating only; 3 = 3=Cooling only; 4 = 4=Heating and cooling from DI USINT	1					Thermoregulation type
16546	_1158_H09	H09	0=Relay only; 1=Relay and compressor; 2=No relay (heating and cooling) USINT	0					Dehumidification type

Address	ID	Label	Values Device Type	Default	Min	Max	Unit	Format	Description
16547	_1159_H11	H11	0 = Disabled; 1 = NO, Defrost request; 255 = NC, Defrost request; 2 = NO, Economy; 254 = NC, Economy; 4 = NO, Door switch; 252 = NC, Door switch; 5 = NO, External alarm; 251 = NC, External alarm ; 7 = NO, Stand-by; 249 = NC, Stand-by; 11 = NO, Pressure switch; 245 = NC, Pressure switch; 14 = NO, Light; 242 = NC, Light; 15 = NO, Ventilation; 241 = NC, Ventilation; 18 = NO, Panic; 238 = NC, Panic; 20 = NO, Heat/Cool; 236 = NC, Heat/Cool; 21 = NO, AUTO mode request; 235 = NC, AUTO mode request USINT	7					DIL1 configuration
16548	_1160_H12	H12	0 = Disabled; 1 = NO, Defrost request; 255 = NC, Defrost request; 2 = NO, Economy; 254 = NC, Economy; 4 = NO, Door switch; 252 = NC, Door switch; 5 = NO, External alarm; 251 = NC, External alarm ; 7 = NO, Stand-by; 249 = NC, Stand-by; 11 = NO, Pressure switch; 245 = NC, Pressure switch; 14 = NO, Light; 242 = NC, Light; 15 = NO, Ventilation; 241 = NC, Ventilation; 18 = NO, Panic; 238 = NC, Panic; 20 = NO, Heat/Cool; 236 = NC, Heat/Cool; 21 = NO, AUTO mode request; 235 = NC, AUTO mode request USINT	4					DIL2 configuration
16549	_H13	H13	0 = Disabled; 1 = NO, Defrost request; 255 = NC, Defrost request; 2 = NO, Economy; 254 = NC, Economy; 4 = NO, Door switch; 252 = NC, Door switch; 5 = NO, External alarm; 251 = NC, External alarm ; 7 = NO, Stand-by; 249 = NC, Stand-by; 11 = NO, Pressure switch; 245 = NC, Pressure switch; 14 = NO, Light; 242 = NC, Light; 15 = NO, Ventilation; 241 = NC, Ventilation; 18 = NO, Panic; 238 = NC, Panic; 20 = NO, Heat/Cool; 236 = NC, Heat/Cool; 21 = NO, AUTO mode request; 235 = NC, AUTO mode request USINT	11					DIL3 configuration

Address	ID	Label	Values Device Type	Default	Min	Max	Unit	Format	Description
16550	_H14	H14	0 = Disabled; 1 = NO, Defrost request; 255 = NC, Defrost request; 2 = NO, Economy; 254 = NC, Economy; 4 = NO, Door switch; 252 = NC, Door switch; 5 = NO, External alarm; 251 = NC, External alarm ; 7 = NO, Stand-by; 249 = NC, Stand-by; 11 = NO, Pressure switch; 245 = NC, Pressure switch; 14 = NO, Light; 242 = NC, Light; 15 = NO, Ventilation; 241 = NC, Ventilation; 18 = NO, Panic; 238 = NC, Panic; 20 = NO, Heat/Cool; 236 = NC, Heat/Cool; 21 = NO, AUTO mode request; 235 = NC, AUTO mode request USINT	21					DIL4 configuration
16551	_H15	H15	0 = Disabled; 1 = NO, Defrost request; 255 = NC, Defrost request; 2 = NO, Economy; 254 = NC, Economy; 4 = NO, Door switch; 252 = NC, Door switch; 5 = NO, External alarm; 251 = NC, External alarm ; 7 = NO, Stand-by; 249 = NC, Stand-by; 11 = NO, Pressure switch; 245 = NC, Pressure switch; 14 = NO, Light; 242 = NC, Light; 15 = NO, Ventilation; 241 = NC, Ventilation; 18 = NO, Panic; 238 = NC, Panic; 20 = NO, Heat/Cool; 236 = NC, Heat/Cool; 21 = NO, AUTO mode request; 235 = NC, AUTO mode request USINT	5					DIL5 configuration
16552	_H16	H16	0 = Disabled; 1 = NO, Defrost request; 255 = NC, Defrost request; 2 = NO, Economy; 254 = NC, Economy; 4 = NO, Door switch; 252 = NC, Door switch; 5 = NO, External alarm; 251 = NC, External alarm ; 7 = NO, Stand-by; 249 = NC, Stand-by; 11 = NO, Pressure switch; 245 = NC, Pressure switch; 14 = NO, Light; 242 = NC, Light; 15 = NO, Ventilation; 241 = NC, Ventilation; 18 = NO, Panic; 238 = NC, Panic; 20 = NO, Heat/Cool; 236 = NC, Heat/Cool; 21 = NO, AUTO mode request; 235 = NC, AUTO mode request USINT	1					DIL6 configuration

Address	ID	Label	Values Device Type	Default	Min	Max	Unit	Format	Description
16556	H23	H23	1=Dehumidifier; 2=Electric defrost USINT	1					DOL3 configuration
16557	_1168_H26	H26	0=Disabled; 4 = 4=Alarm; 7 = 7=Light; 111=Ventilation fan USINT	7					DOL6 configuration
16558	_1169_H27	H27	0=Disabled; 4 = 4=Alarm; 7 = 7=Light; 111=Ventilation fan USINT	0					DOL7 configuration
16569	_1180_H41	H41	0=Disabled; 1=Analog input 1; 2=Analog input 2; 3 = 3=Analog input 3; 4 = 4=Analog input 4; 5 = 5=Analog input 5 USINT	1					Probe 1 - cabinet temperature - configuration
16570	_1181_H42	H42	0=Disabled; 1=Analog input 1; 2=Analog input 2; 3 = 3=Analog input 3; 4 = 4=Analog input 4; 5 = 5=Analog input 5 USINT	2					Probe 2 - evaporator temperature - configuration
16571	_1182_H43	H43	0=Disabled; 3 = 3=Analog input 3; 4 = 4=Analog input 4 USINT	3					Probe 3 - humidity - configuration
16572	_1183_H44	H44	0=Disabled; 1=Analog input 1; 2=Analog input 2; 3 = 3=Analog input 3; 4 = 4=Analog input 4; 5 = 5=Analog input 5 USINT	4					Probe 4 - A.O. regulation - configuration
16578	_1189_dEt	dEt	Unsigned 16-bit UINT	30	1	255	min		Defrost timeout
16600	dE1	dE1	Signed 16-bit INT	1440	0	1440		HH:MM	Defrost event #1 on working days
16601	dE2	dE2	Signed 16-bit INT	1440	0	1440		HH:MM	Defrost event #2 on working days
16602	dE3	dE3	Signed 16-bit INT	1440	0	1440		HH:MM	Defrost event #3 on working days
16603	dE4	dE4	Signed 16-bit INT	1440	0	1440		HH:MM	Defrost event #4 on working days
16604	dE5	dE5	Signed 16-bit INT	1440	0	1440		HH:MM	Defrost event #5 on working days
16605	dE6	dE6	Signed 16-bit INT	1440	0	1440		HH:MM	Defrost event #6 on working days
16606	dE7	dE7	Signed 16-bit INT	1440	0	1440		HH:MM	Defrost event #7 on working days
16607	dE8	dE8	Signed 16-bit INT	1440	0	1440		HH:MM	Defrost event #8 on working days
16608	F1	F1	Signed 16-bit INT	1440	0	1440		HH:MM	Defrost event #1 during week-end

Address	ID	Label	Values Device Type	Default	Min	Max	Unit	Format	Description
16609	F2	F2	Signed 16-bit INT	1440	0	1440		HH:MM	Defrost event #2 during week-end
16610	F3	F3	Signed 16-bit INT	1440	0	1440		HH:MM	Defrost event #3 during week-end
16611	F4	F4	Signed 16-bit INT	1440	0	1440		HH:MM	Defrost event #4 during week-end
16612	F5	F5	Signed 16-bit INT	1440	0	1440		HH:MM	Defrost event #5 during week-end
16613	F6	F6	Signed 16-bit INT	1440	0	1440		HH:MM	Defrost event #6 during week-end
16614	F7	F7	Signed 16-bit INT	1440	0	1440			Defrost event #7 during week-end
16615	F8	F8	Signed 16-bit INT	1440	0	1440		HH:MM	Defrost event #8 during week-end
16616	STEP1_P0	1P0	Unsigned 16-bit UINT	0	0	5999	min		Step 1 activation delay
16617	STEP1_P1	1P1	Unsigned 16-bit UINT	60	0	5999	min		Step 1 duration
16618	STEP1_P2	1P2	0=Disabled; 1=Neutral zone; 2=Humidification only; 3 = 3=Dehumidification only USINT	1					Step 1 humidity regulation type
16619	STEP1_P3	1P3	0=Disabled; 1=Neutral zone; 2=Heating only; 3 = 3=Cooling only; 4 = 4=Heating and cooling from DI USINT	1					Step 1 thermoregulation type
16620	STEP1_P4	1P4	Signed 16-bit INT	500	_1023_LSH	_1022_HSH	%R.H.	XXX.Y	Step 1 humidity setpoint
16621	STEP1_P5	1P5	Signed 16-bit INT	0	_1004_LSE	_1003_HSE	°C	XXX.Y	Step 1 temperature setpoint 1
16622	STEP1_P6	1P6	Signed 16-bit INT	0	_1004_LSE	_1003_HSE	°C	XXX.Y	Step 1 temperature setpoint 2
16623	STEP1_P7	1P7	Boolean BOOL	0					Step 1 AUX relay activation status
16624	STEP1_P8	1P8	1=End; 2=Next (continue); 3 = 3=Next (suspend); 4 = 4=Loop; 5 = 5=Go to step; 6 = 6=Everlasting USINT	1					Step 1 end action
16625	STEP1_P9	1P9	1=STEP 1; 2=STEP 2; 3 = 3=STEP 3; 4 = 4=STEP 4; 5 = 5=STEP 5; 6 = 6=STEP 6; 7 = 7=STEP 7; 8 = 8=STEP 8 USINT	0					Step 1 jump back destination
16626	STEP2_P0	2P0	Unsigned 16-bit UINT	0	0	5999	min		Step 2 activation delay
16627	STEP2_P1	2P1	Unsigned 16-bit UINT	60	0	5999	min		Step 2 duration
16628	STEP2_P2	2P2	0=Disabled; 1=Neutral zone; 2=Humidification only; 3 = 3=Dehumidification only USINT	1					Step 2 humidity regulation type

Address	ID	Label	Values Device Type	Default	Min	Max	Unit	Format	Description
16629	STEP2_P3	2P3	0=Disabled; 1=Neutral zone; 2=Heating only; 3 = 3=Cooling only; 4 = 4=Heating and cooling from DI USINT	1					Step 2 thermoregulation type
16630	STEP2_P4	2P4	Signed 16-bit INT	500	_1023_LSH	_1022_HSH	%R.H.	XXX.Y	Step 2 humidity setpoint
16631	STEP2_P5	2P5	Signed 16-bit INT	0	_1004_LSE	_1003_HSE	°C	XXX.Y	Step 2 temperature setpoint 1
16632	STEP2_P6	2P6	Signed 16-bit INT	0	_1004_LSE	_1003_HSE	°C	XXX.Y	Step 2 temperature setpoint 2
16633	STEP2_P7	2P7	Boolean BOOL	0					Step 2 AUX relay activation status
16634	STEP2_P8	2P8	1=End; 2=Next (continue); 3 = 3=Next (suspend); 4 = 4=Loop; 5 = 5=Go to step; 6 = 6=Everlasting USINT	1					Step 2 end action
16635	STEP2_P9	2P9	1=STEP 1; 2=STEP 2; 3 = 3=STEP 3; 4 = 4=STEP 4; 5 = 5=STEP 5; 6 = 6=STEP 6; 7 = 7=STEP 7; 8 = 8=STEP 8 USINT	0					Step 2 jump back destination
16636	STEP3_P0	3P0	Unsigned 16-bit UINT	0	0	5999	min		Step 3 activation delay
16637	STEP3_P1	3P1	Unsigned 16-bit UINT	60	0	5999	min		Step 3 duration
16638	STEP3_P2	3P2	0=Disabled; 1=Neutral zone; 2=Humidification only; 3 = 3=Dehumidification only USINT	1					Step 3 humidity regulation type
16639	STEP3_P3	3P3	0=Disabled; 1=Neutral zone; 2=Heating only; 3 = 3=Cooling only; 4 = 4=Heating and cooling from DI USINT	1					Step 3 thermoregulation type
16640	STEP3_P4	3P4	Signed 16-bit INT	500	_1023_LSH	_1022_HSH	%R.H.	XXX.Y	Step 3 humidity setpoint
16641	STEP3_P5	3P5	Signed 16-bit INT	0	_1004_LSE	_1003_HSE	°C	XXX.Y	Step 3 temperature setpoint 1
16642	STEP3_P6	3P6	Signed 16-bit INT	0	_1004_LSE	_1003_HSE	°C	XXX.Y	Step 3 temperature setpoint 2
16643	STEP3_P7	3P7	Boolean BOOL	0					Step 3 AUX relay activation status
16644	STEP3_P8	3P8	1=End; 2=Next (continue); 3 = 3=Next (suspend); 4 = 4=Loop; 5 = 5=Go to step; 6 = 6=Everlasting USINT	1					Step 3 end action
16645	STEP3_P9	3P9	1=STEP 1; 2=STEP 2; 3 = 3=STEP 3; 4 = 4=STEP 4; 5 = 5=STEP 5; 6 = 6=STEP 6; 7 = 7=STEP 7; 8 = 8=STEP 8 USINT	0					Step 3 jump back destination
16646	STEP4_P0	4P0	Unsigned 16-bit UINT	0	0	5999	min		Step 4 activation delay
16647	STEP4_P1	4P1	Unsigned 16-bit UINT	60	0	5999	min		Step 4 duration

Address	ID	Label	Values Device Type	Default	Min	Max	Unit	Format	Description
16648	STEP4_P2	4P2	0=Disabled; 1=Neutral zone; 2=Humidification only; 3 = 3=Dehumidification only USINT	1					Step 4 humidity regulation type
16649	STEP4_P3	4P3	0=Disabled; 1=Neutral zone; 2=Heating only; 3 = 3=Cooling only; 4 = 4=Heating and cooling from DI USINT	1					Step 4 thermoregulation type
16650	STEP4_P4	4P4	Signed 16-bit INT	500	_1023_LSH	_1022_HSH	%R.H.	XXX.Y	Step 4 humidity setpoint
16651	STEP4_P5	4P5	Signed 16-bit INT	0	_1004_LSE	_1003_HSE	°C	XXX.Y	Step 4 temperature setpoint 1
16652	STEP4_P6	4P6	Signed 16-bit INT	0	_1004_LSE	_1003_HSE	°C	XXX.Y	Step 4 temperature setpoint 2
16653	STEP4_P7	4P7	Boolean BOOL	0					Step 4 AUX relay activation status
16654	STEP4_P8	4P8	1=End; 2=Next (continue); 3 = 3=Next (suspend); 4 = 4=Loop; 5 = 5=Go to step; 6 = 6=Everlasting USINT	1					Step 4 end action
16655	STEP4_P9	4P9	1=STEP 1; 2=STEP 2; 3 = 3=STEP 3; 4 = 4=STEP 4; 5 = 5=STEP 5; 6 = 6=STEP 6; 7 = 7=STEP 7; 8 = 8=STEP 8 USINT	0					Step 4 jump back destination
16656	STEP5_P0	5P0	Unsigned 16-bit UINT	0	0	5999	min		Step 5 activation delay
16657	STEP5_P1	5P1	Unsigned 16-bit UINT	60	0	5999	min		Step 5 duration
16658	STEP5_P2	5P2	0=Disabled; 1=Neutral zone; 2=Humidification only; 3 = 3=Dehumidification only USINT	1					Step 5 humidity regulation type
16659	STEP5_P3	5P3	0=Disabled; 1=Neutral zone; 2=Heating only; 3 = 3=Cooling only; 4 = 4=Heating and cooling from DI USINT	1					Step 5 thermoregulation type
16660	STEP5_P4	5P4	Signed 16-bit INT	500	_1023_LSH	_1022_HSH	%R.H.	XXX.Y	Step 5 humidity setpoint
16661	STEP5_P5	5P5	Signed 16-bit INT	0	_1004_LSE	_1003_HSE	°C	XXX.Y	Step 5 temperature setpoint 1
16662	STEP5_P6	5P6	Signed 16-bit INT	0	_1004_LSE	_1003_HSE	°C	XXX.Y	Step 5 temperature setpoint 2
16663	STEP5_P7	5P7	Boolean BOOL	0					Step 5 AUX relay activation status
16664	STEP5_P8	5P8	1=End; 2=Next (continue); 3 = 3=Next (suspend); 4 = 4=Loop; 5 = 5=Go to step; 6 = 6=Everlasting USINT	1					Step 5 end action
16665	STEP5_P9	5P9	1=STEP 1; 2=STEP 2; 3 = 3=STEP 3; 4 = 4=STEP 4; 5 = 5=STEP 5; 6 = 6=STEP 6; 7 = 7=STEP 7; 8 = 8=STEP 8 USINT	0					Step 5 jump back destination

Address	ID	Label	Values Device Type	Default	Min	Max	Unit	Format	Description
16666	STEP6_P0	6P0	Unsigned 16-bit UINT	0	0	5999	min		Step 6 activation delay
16667	STEP6_P1	6P1	Unsigned 16-bit UINT	60	0	5999	min		Step 6 duration
16668	STEP6_P2	6P2	0=Disabled; 1=Neutral zone; 2=Humidification only; 3 = 3=Dehumidification only USINT	1					Step 6 humidity regulation type
16669	STEP6_P3	6P3	0=Disabled; 1=Neutral zone; 2=Heating only; 3 = 3=Cooling only; 4 = 4=Heating and cooling from DI USINT	1					Step 6 thermoregulation type
16670	STEP6_P4	6P4	Signed 16-bit INT	500	_1023_LSH	_1022_HSH	%R.H.	XXX.Y	Step 6 humidity setpoint
16671	STEP6_P5	6P5	Signed 16-bit INT	0	_1004_LSE	_1003_HSE	°C	XXX.Y	Step 6 temperature setpoint 1
16672	STEP6_P6	6P6	Signed 16-bit INT	0	_1004_LSE	_1003_HSE	°C	XXX.Y	Step 6 temperature setpoint 2
16673	STEP6_P7	6P7	Boolean BOOL	0					Step 6 AUX relay activation status
16674	STEP6_P8	6P8	1=End; 2=Next (continue); 3 = 3=Next (suspend); 4 = 4=Loop; 5 = 5=Go to step; 6 = 6=Everlasting USINT	1					Step 6 end action
16675	STEP6_P9	6P9	1=STEP 1; 2=STEP 2; 3 = 3=STEP 3; 4 = 4=STEP 4; 5 = 5=STEP 5; 6 = 6=STEP 6; 7 = 7=STEP 7; 8 = 8=STEP 8 USINT	0					Step 6 jump back destination
16676	STEP7_P0	7P0	Unsigned 16-bit UINT	0	0	5999	min		Step 7 activation delay
16677	STEP7_P1	7P1	Unsigned 16-bit UINT	60	0	5999	min		Step 7 duration
16678	STEP7_P2	7P2	0=Disabled; 1=Neutral zone; 2=Humidification only; 3 = 3=Dehumidification only USINT	1					Step 7 humidity regulation type
16679	STEP7_P3	7P3	0=Disabled; 1=Neutral zone; 2=Heating only; 3 = 3=Cooling only; 4 = 4=Heating and cooling from DI USINT	1					Step 7 thermoregulation type
16680	STEP7_P4	7P4	Signed 16-bit INT	500	_1023_LSH	_1022_HSH	%R.H.	XXX.Y	Step 7 humidity setpoint
16681	STEP7_P5	7P5	Signed 16-bit INT	0	_1004_LSE	_1003_HSE	°C	XXX.Y	Step 7 temperature setpoint 1
16682	STEP7_P6	7P6	Signed 16-bit INT	0	_1004_LSE	_1003_HSE	°C	XXX.Y	Step 7 temperature setpoint 2
16683	STEP7_P7	7P7	Boolean BOOL	0					Step 7 AUX relay activation status
16684	STEP7_P8	7P8	1=End; 2=Next (continue); 3 = 3=Next (suspend); 4 = 4=Loop; 5 = 5=Go to step; 6 = 6=Everlasting USINT	1					Step 7 end action

Address	ID	Label	Values Device Type	Default	Min	Max	Unit	Format	Description
16685	STEP7_P9	7P9	1=STEP 1; 2=STEP 2; 3 = 3=STEP 3; 4 = 4=STEP 4; 5 = 5=STEP 5; 6 = 6=STEP 6; 7 = 7=STEP 7; 8 = 8=STEP 8 USINT	0					Step 7 jump back destination
16686	STEP8_P0	8P0	Unsigned 16-bit UINT	0	0	5999	min		Step 8 activation delay
16687	STEP8_P1	8P1	Unsigned 16-bit UINT	60	0	5999	min		Step 8 duration
16688	STEP8_P2	8P2	0=Disabled; 1=Neutral zone; 2=Humidification only; 3 = 3=Dehumidification only USINT	1					Step 8 humidity regulation type
16689	STEP8_P3	8P3	0=Disabled; 1=Neutral zone; 2=Heating only; 3 = 3=Cooling only; 4 = 4=Heating and cooling from DI USINT	1					Step 8 thermoregulation type
16690	STEP8_P4	8P4	Signed 16-bit INT	500	_1023_LSH	_1022_HSH	%R.H.	XXX.Y	Step 8 humidity setpoint
16691	STEP8_P5	8P5	Signed 16-bit INT	0	_1004_LSE	_1003_HSE	°C	XXX.Y	Step 8 temperature setpoint 1
16692	STEP8_P6	8P6	Signed 16-bit INT	0	_1004_LSE	_1003_HSE	°C	XXX.Y	Step 8 temperature setpoint 2
16693	STEP8_P7	8P7	Boolean BOOL	0					Step 8 AUX relay activation status
16694	STEP8_P8	8P8	1=End; 2=Next (continue); 3 = 3=Next (suspend); 4 = 4=Loop; 5 = 5=Go to step; 6 = 6=Everlasting USINT	1					Step 8 end action
16695	STEP8_P9	8P9	1=STEP 1; 2=STEP 2; 3 = 3=STEP 3; 4 = 4=STEP 4; 5 = 5=STEP 5; 6 = 6=STEP 6; 7 = 7=STEP 7; 8 = 8=STEP 8 USINT	0					Step 8 jump back destination
16696	LocalState	Lst	0=Off; 1=On USINT	0					Local state setting (ON/OFF)
16697	CompressorUptimeHoursCopy		Signed 16-bit INT	0			h		Compressor uptime hours
16698	CompressorUptimeFractionCopy		Unsigned 16-bit UINT	0			s		Compressor uptime hour fraction (in seconds)
16699	UnitUptimeHoursCopy		Signed 16-bit INT	0			h		Unit uptime hours
16700	UnitUptimeFractionCopy		Unsigned 16-bit UINT	0			s		Unit uptime hour fraction (in seconds)
16714	Fond_Dispart_SMART	FdSS	1=Pb1; 3 = 3=Pb2; 5 = 5=Pb3; 7 = 7=Pb4; 9 = 9=StEP; 10 = 10=State USINT	1					Start up fundamental display state

Address	ID	Label	Values Device Type	Default	Min	Max	Unit	Format	Description
16715	Fond_Dynamic_Mode_SMART	FdMO	Boolean BOOL	1					Dynamic fundamental state mode (Enable/Disable)
16716	KeyUP_Short_Function	UPSF	0=NotUsed; 1=System ON - OFF Toggle Request; 2=Defrost Request; 3 = 3=Light Toggle ON OFF Request; 4 = 4=AlarmReset Request; 5 = 5=Economy Mode Request; 6 = 6=Start Stop Program; 7 = 7=Dinamic Display ON OFF Request USINT	3					Function associated to the UP key short pressed
16717	KeyUP_Long_Function	UPLF	0=NotUsed; 1=System ON - OFF Toggle Request; 2=Defrost Request; 3 = 3=Light Toggle ON OFF Request; 4 = 4=AlarmReset Request; 5 = 5=Economy Mode Request; 6 = 6=Start Stop Program; 7 = 7=Dinamic Display ON OFF Request USINT	6					Function associated to the UP key long pressed
16718	KeyDW_Short_Function	DWFS	0=NotUsed; 1=System ON - OFF Toggle Request; 2=Defrost Request; 3 = 3=Light Toggle ON OFF Request; 4 = 4=AlarmReset Request; 5 = 5=Economy Mode Request; 6 = 6=Start Stop Program; 7 = 7=Dinamic Display ON OFF Request USINT	7					Function associated to the DOWN key short pressed
16719	KeyDW_Long_Function	DWLF	0=NotUsed; 1=System ON - OFF Toggle Request; 2=Defrost Request; 3 = 3=Light Toggle ON OFF Request; 4 = 4=AlarmReset Request; 5 = 5=Economy Mode Request; 6 = 6=Start Stop Program; 7 = 7=Dinamic Display ON OFF Request USINT	2					Function associated to the DOWN key long pressed

Address	ID	Label	Values Device Type	Default	Min	Max	Unit	Format	Description
16720	KeyESC_Long_Function	ESCF	0=NotUsed; 1=System ON - OFF Toggle Request; 2=Defrost Request; 3 = 3=Light Toggle ON OFF Request; 4 = 4=AlarmReset Request; 5 = 5=Economy Mode Request; 6 = 6=Start Stop Program; 7 = 7=Dinamic Display ON OFF Request USINT	4					Function associated to the ESC key long pressed
16721	KeySET_Long_Function	SETF	0=NotUsed; 1=System ON - OFF Toggle Request; 2=Defrost Request; 3 = 3=Light Toggle ON OFF Request; 4 = 4=AlarmReset Request; 5 = 5=Economy Mode Request; 6 = 6=Start Stop Program; 7 = 7=Dinamic Display ON OFF Request USINT	1					Function associated to the SET key long pressed
16722	LogData_NextEntry_Code		Unsigned 16-bit UINT	0					Position Index where next data will be logged
16723	LogData_FULL_Code		Boolean BOOL	0					Full Queue Flag
16724	LogDataE2_00	L000	Signed 16-bit INT	32767					This Must Be always declared
16725	LogDataE2_01	L001	Signed 16-bit INT	32767					
16726	LogDataE2_02	L002	Signed 16-bit INT	32767					
16727	LogDataE2_03	L003	Signed 16-bit INT	32767					
16728	LogDataE2_04	L004	Signed 16-bit INT	32767					
16729	LogDataE2_05	L005	Signed 16-bit INT	32767					
16730	LogDataE2_06	L006	Signed 16-bit INT	32767					
16731	LogDataE2_07	L007	Signed 16-bit INT	32767					
16732	LogDataE2_08	L008	Signed 16-bit INT	32767					
16733	LogDataE2_09	L009	Signed 16-bit INT	32767					
16734	LogDataE2_10	L010	Signed 16-bit INT	32767					
16735	LogDataE2_11	L011	Signed 16-bit INT	32767					

Address	ID	Label	Values Device Type	Default	Min	Max	Unit	Format	Description
16736	LogDataE2_12	L012	Signed 16-bit INT	32767					
16737	LogDataE2_13	L013	Signed 16-bit INT	32767					
16738	LogDataE2_14	L014	Signed 16-bit INT	32767					
16739	LogDataE2_15	L015	Signed 16-bit INT	32767					
16740	LogDataE2_16	L016	Signed 16-bit INT	32767					
16741	LogDataE2_17	L017	Signed 16-bit INT	32767					
16742	LogDataE2_18	L018	Signed 16-bit INT	32767					
16743	LogDataE2_19	L019	Signed 16-bit INT	32767					
16744	LogDataE2_20	L020	Signed 16-bit INT	32767					
16745	LogDataE2_21	L021	Signed 16-bit INT	32767					
16746	LogDataE2_22	L022	Signed 16-bit INT	32767					
16747	LogDataE2_23	L023	Signed 16-bit INT	32767					
16748	LogDataE2_24	L024	Signed 16-bit INT	32767					
16749	LogDataE2_25	L025	Signed 16-bit INT	32767					
16750	LogDataE2_26	L026	Signed 16-bit INT	32767					
16751	LogDataE2_27	L027	Signed 16-bit INT	32767					
16752	LogDataE2_28	L028	Signed 16-bit INT	32767					
16753	LogDataE2_29	L029	Signed 16-bit INT	32767					
16754	LogDataE2_30	L030	Signed 16-bit INT	32767					
16755	LogDataE2_31	L031	Signed 16-bit INT	32767					
16756	LogDataE2_32	L032	Signed 16-bit INT	32767					
16757	LogDataE2_33	L033	Signed 16-bit INT	32767					
16758	LogDataE2_34	L034	Signed 16-bit INT	32767					
16759	LogDataE2_35	L035	Signed 16-bit INT	32767					

Address	ID	Label	Values Device Type	Default	Min	Max	Unit	Format	Description
16760	LogDataE2_36	L036	Signed 16-bit INT	32767					
16761	LogDataE2_37	L037	Signed 16-bit INT	32767					
16762	LogDataE2_38	L038	Signed 16-bit INT	32767					
16763	LogDataE2_39	L039	Signed 16-bit INT	32767					
16764	LogDataE2_40	L040	Signed 16-bit INT	32767					
16765	LogDataE2_41	L041	Signed 16-bit INT	32767					
16766	LogDataE2_42	L042	Signed 16-bit INT	32767					
16767	LogDataE2_43	L043	Signed 16-bit INT	32767					
16768	LogDataE2_44	L044	Signed 16-bit INT	32767					
16769	LogDataE2_45	L045	Signed 16-bit INT	32767					
16770	LogDataE2_46	L046	Signed 16-bit INT	32767					
16771	LogDataE2_47	L047	Signed 16-bit INT	32767					
16772	LogDataE2_48	L048	Signed 16-bit INT	32767					
16773	LogDataE2_49	L049	Signed 16-bit INT	32767					
16774	LogDataE2_50	L050	Signed 16-bit INT	32767					
16775	LogDataE2_51	L051	Signed 16-bit INT	32767					
16776	LogDataE2_52	L052	Signed 16-bit INT	32767					
16777	LogDataE2_53	L053	Signed 16-bit INT	32767					
16778	LogDataE2_54	L054	Signed 16-bit INT	32767					
16779	LogDataE2_55	L055	Signed 16-bit INT	32767					
16780	LogDataE2_56	L056	Signed 16-bit INT	32767					
16781	LogDataE2_57	L057	Signed 16-bit INT	32767					
16782	LogDataE2_58	L058	Signed 16-bit INT	32767					
16783	LogDataE2_59	L059	Signed 16-bit INT	32767					

Address	ID	Label	Values Device Type	Default	Min	Max	Unit	Format	Description
16784	LogData_NextEntry_Date		Unsigned 16-bit UINT	0					
16785	LogData_FULL_Date		Boolean BOOL	0					
16786	LogData_NextEntry_Time		Unsigned 16-bit UINT	0					
16787	LogData_FULL_Time		Boolean BOOL	0					
16788	LogData_NextEntry_V1		Unsigned 16-bit UINT	0					
16789	LogData_FULL_V1		Boolean BOOL	0					
16790	LogData_NextEntry_V2		Unsigned 16-bit UINT	0					
16791	LogData_FULL_V2		Boolean BOOL	0					
16792	LogData_NextEntry_V3		Unsigned 16-bit UINT	0					
16793	LogData_FULL_V3		Boolean BOOL	0					

16.14.3 Client table (Status Variables)

The table below lists all application configuration status including Modbus addresses

Address	ID	Values Device Type	Unit	Format	ReadOnly	Description
8960	CurrentState	0=Off; 1=On USINT			R	Current ON/OFF state
8961	CurrentMode	0=Heating; 1=Cooling; 2=Neutral zone USINT			R	Current HEAT/COOL mode
8962	CurrentTemperatureSetpoint	Signed 16-bit INT	°C	XXX.Y	R	Current temperature setpoint
8963	TemperatureSetpoint1	Signed 16-bit INT	°C	XXX.Y	R	Temperature setpoint 1
8964	TemperatureSetpoint2	Signed 16-bit INT	°C	XXX.Y	R	Temperature setpoint 2
8965	HumiditySetpoint	Signed 16-bit INT	%R.H.	XXX.Y	R	Humidity setpoint
8966	ThermoregulationType	0=Disabled; 1=Neutral zone; 2=Heating only; 3 = 3=Cooling only; 4 = 4=Heating and cooling from DI USINT			R	Thermoregulation type
8967	HumidityRegulationType	0=Not active; 1=Active USINT			R	Humidity regulation type
8968	CurrentStep	Unsigned 16-bit USINT			RW	Current step number, in AUTO mode
8969	CurrentStepState	0=START; 1=RUN; 2=STOP USINT			RW	Current step state, in AUTO mode
8970	CurrentStepTimeUINT	Unsigned 16-bit UINT	min		R	Current step time, in AUTO mode
8976	ResetAlarm	Boolean BOOL			RW	Reset alarm request
8977	Pb1Enabled	Boolean BOOL			R	Probe 1 enable status (if TRUE, it is enabled)
8978	Pb1	Signed 16-bit INT	°C	XXX.Y	R	Probe 1 = thermoregulation feedback
8979	Pb1ErrorMdb	0=Inactive; 1=Active; 2=Resettable USINT			R	Probe 1 error
8980	Pb2Enabled	Boolean BOOL			R	Probe 2 enable status (if TRUE, it is enabled)
8981	Pb2	Signed 16-bit INT	°C	XXX.Y	R	Probe 2 = evaporator temperature
8982	Pb2ErrorMdb	0=Inactive; 1=Active; 2=Resettable USINT			R	Probe 2 error
8983	Pb3Enabled	Boolean BOOL			R	Probe 3 enable status (if TRUE, it is enabled)

Address	ID	Values Device Type	Unit	Format	ReadOnly	Description
8984	Pb3	Signed 16-bit INT	%R.H.	XXX.Y	R	Probe 3 = humidity
8985	Pb3ErrorMdb	0=Inactive; 1=Active; 2=Resettable USINT			R	Probe 3 error
8986	Pb4Enabled	Boolean BOOL			R	Probe 4 enable status (if TRUE, it is enabled)
8987	Pb4	Signed 16-bit INT		XXX.Y	R	Probe 4 = A.O. regulation
8988	Pb4ErrorMdb	0=Inactive; 1=Active; 2=Resettable USINT			R	Probe 4 error
8989	ExternalAlarmMdb	0=Inactive; 1=Active; 2=Resettable USINT			R	External alarm
8990	PanicAlarmMdb	0=Inactive; 1=Active; 2=Resettable USINT			R	Panic alarm
8991	DoorOpenAlarmMdb	0=Inactive; 1=Active; 2=Resettable USINT			R	Door open alarm
8992	PressureAlarmMdb	0=Inactive; 1=Active; 2=Resettable USINT			R	Pressure alarm
8993	HighTemperatureAlarmMdb	0=Inactive; 1=Active; 2=Resettable USINT			R	High temperature alarm
8994	LowTemperatureAlarmMdb	0=Inactive; 1=Active; 2=Resettable USINT			R	Low temperature alarm
8995	DefrostTimeoutAlarmMdb	0=Inactive; 1=Active; 2=Resettable USINT			R	Defrost timeout alarm
8996	HighHumidityAlarmMdb	0=Inactive; 1=Active; 2=Resettable USINT			R	High humidity alarm
8997	LowHumidityAlarmMdb	0=Inactive; 1=Active; 2=Resettable USINT			R	Low humidity alarm
8998	ClockErrorMdb	0=Inactive; 1=Active; 2=Resettable USINT			R	System clock error
8999	GlobalAlarmStatus	0=Inactive; 1=Active; 2=Resettable USINT			R	Global alarm status
9000	EconomyDIEnabled	Boolean BOOL			R	Economy DI configuration status (if TRUE, it is enabled)
9001	EconomyDI	0=Inactive; 1=Active BOOL			R	Economy DI
9002	DoorSwitchEnabled	Boolean BOOL			R	Door switch configuration status (if TRUE, it is enabled)
9003	DoorSwitch	0=Inactive; 1=Active BOOL			R	Door switch
9004	AlarmDIEnabled	Boolean BOOL			R	Alarm DI configuration status (if TRUE, it is enabled)
9005	AlarmDI	0=Inactive; 1=Active BOOL			R	Alarm DI

Address	ID	Values Device Type	Unit	Format	ReadOnly	Description
9006	StateDIEnabled	Boolean BOOL			R	State (ON/OFF) DI configuration status (if TRUE, it is enabled)
9007	RemoteState	0=Off; 1=On USINT			R	Remote ON/OFF state setting (from digital input)
9008	LightDIEnabled	Boolean BOOL			R	Light DI configuration status (if TRUE, it is enabled)
9009	LightDI	0=Inactive; 1=Active BOOL			R	Light DI
9010	VentilationDIEnabled	Boolean BOOL			R	Ventilation DI configuration status (if TRUE, it is enabled)
9011	VentilationDI	0=Inactive; 1=Active BOOL			R	Ventilation DI
9012	PressureSwitchEnabled	Boolean BOOL			R	Pressure switch configuration status (if TRUE, it is enabled)
9013	PressureSwitch	0=Inactive; 1=Active BOOL			R	Pressure switch
9014	PanicDIEnabled	Boolean BOOL			R	Panic DI configuration status (if TRUE, it is enabled)
9015	PanicDI	0=Inactive; 1=Active BOOL			R	Panic DI
9016	ModeDIEnabled	Boolean BOOL			R	Mode DI configuration status (if TRUE, it is enabled)
9017	ModeDI	0=Heating; 1=Cooling USINT			R	Mode DI
9076	DefrostDIEnabled	Boolean BOOL			R	Defrost from DI configuration status (if TRUE, it is enabled)
9077	DefrostDI	0=Inactive; 1=Active BOOL			R	Defrost from DI
9078	AutoModeDIEnabled	Boolean BOOL			R	AUTO mode request from DI configuration status (if TRUE, it is enabled)
9079	AutoModeDI	0=Inactive; 1=Active BOOL			R	AUTO mode request from DI
9018	CompressorDO	0=Inactive; 1=Active BOOL			R	Compressor DO
9019	DehumidifierDOEnabled	Boolean BOOL			R	Dehumidifier DO configuration status (if TRUE, it is enabled)
9020	DehumidifierDO	0=Inactive; 1=Active BOOL			R	Dehumidifier DO
9021	DefrostDOEnabled	Boolean BOOL			R	Defrost DO configuration status (if TRUE, it is enabled)
9022	DefrostDO	0=Inactive; 1=Active BOOL			R	Defrost DO
9023	HeaterDO	0=Inactive; 1=Active BOOL			R	Heater DO
9024	EvaporatorFansDO	0=Inactive; 1=Active BOOL			R	Evaporator fans DO
9025	HumidifierDO	0=Inactive; 1=Active BOOL			R	Humidifier DO

Address	ID	Values Device Type	Unit	Format	ReadOnly	Description
9026	LightDOEnabled	Boolean BOOL			R	Light DO configuration status (if TRUE, it is enabled)
9027	LightDO	0=Inactive; 1=Active BOOL			R	Light DO
9028	VentilationFanDOEnabled	Boolean BOOL			R	Ventilation fan DO configuration status (if TRUE, it is enabled)
9029	VentilationFanDO	0=Inactive; 1=Active BOOL			R	Ventilation fan DO
9030	sysClock_seconds_RW	Unsigned 8-bit USINT			RW	Second value to update
9031	sysClock_minutes_RW	Unsigned 8-bit USINT			RW	Minute value to update
9032	sysClock_hours_RW	Unsigned 8-bit USINT			RW	Hour value to update
9033	sysClock_dayweek_RW	Unsigned 8-bit USINT			RW	Day of the week value to update
9034	sysClock_daymonth_RW	Unsigned 8-bit USINT			RW	Day of the month value to update
9035	sysClock_month_RW	Unsigned 8-bit USINT			RW	Month value to update
9036	sysClock_year_RW	Unsigned 8-bit USINT			RW	Year value to update
9037	sysClock_update	Unsigned 8-bit USINT			RW	Confirm update
9038	ThermoregulationEnabled	Boolean BOOL			R	Thermoregulation configuration status (if TRUE, it is enabled)
9039	CompressorRequest	Boolean BOOL			R	Request to switch on the compressor
9040	HumidificationConfigured	Boolean BOOL			R	Humidification configuration status (if TRUE, it is enabled)
9041	DehumidificationConfigured	Boolean BOOL			R	Dehumidification configuration status (if TRUE, it is enabled)
9042	DehumidificationRequest	Boolean BOOL			R	Active request for dehumidification
9043	CoolingConfigured	Boolean BOOL			R	Cooling configuration status (if TRUE, it is enabled)
9044	CoolingRequest	Boolean BOOL			R	Active request for cooling
9045	CompressorForDehumidification	Boolean BOOL			R	If TRUE, compressor is configured to be used for dehumidification
9046	HeatingConfigured	Boolean BOOL			R	Heating configuration status (if TRUE, it is enabled)

Address	ID	Values Device Type	Unit	Format	ReadOnly	Description
9047	HeatingSetpoint	Signed 16-bit INT	°C	XXX.Y	R	Temperature setpoint for heating
9048	HeaterForDehumidification	Boolean BOOL			R	If TRUE, heater is configured to be used for dehumidification
9049	DehumidifierForDehumidification	Boolean BOOL			R	If TRUE, dehumidifier is configured to be used for dehumidification
9050	DehumidificationEnabled	Boolean BOOL			R	Dehumidification enable status
9051	CoolingEnabled	Boolean BOOL			R	Cooling enable status
9052	HeatingEnabled	Boolean BOOL			R	Heating enable status
9053	HumidificationEnabled	Boolean BOOL			R	Humidification enable status
9054	VentilationEnabled	Boolean BOOL			R	Ventilation enable status
9055	CompressorConsensus	Boolean BOOL			R	Consensus to switch on the compressor
9056	AOEnabled	Boolean BOOL			R	A.O. enable status (if TRUE, it is enabled)
9057	AORequest	Signed 16-bit INT	%		R	A.O. level
9058	DefrostRequest	Boolean BOOL			R	
9059	DefrostEnabled	Boolean BOOL			R	
9060	DefrostActive	Boolean BOOL			R	
9080	DefrostRequestDiscardedWarning	Boolean BOOL			R	Discarded defrost request warning
9061	FunEconomyRequest	Boolean BOOL			RW	
9062	FunEconomy	Boolean BOOL			R	
9063	FunAutoRequest	Boolean BOOL			RW	
9064	FunAuto	Boolean BOOL			R	
9065	ToggleLightRequest	Boolean BOOL			RW	
9066	DefrostHMIRRequest	Boolean BOOL			RW	Defrost request from HMI
9067	ResetCountersHMIRRequest	Boolean BOOL			RW	Reset counters request

Address	ID	Values Device Type	Unit	Format	ReadOnly	Description
9068	CompressorUptimeHours	Signed 16-bit INT	h		R	Compressor uptime hours
9069	CompressorUptimeFractionUINT	Unsigned 16-bit UINT	s		R	Compressor uptime hour fraction (in seconds)
9070	UnitUptimeHours	Signed 16-bit INT	h		R	Unit uptime hours
9071	UnitUptimeFractionUINT	Unsigned 16-bit UINT	s		R	Unit uptime hour fraction (in seconds)
9072	PressureAlarmCount	Unsigned 16-bit UINT			R	Pressure alarm count
9073	StartStopAutoRequest	Boolean BOOL			RW	AUTO mode START/STOP HMI request
9074	ResetAutoRequest	Boolean BOOL			RW	AUTO mode RESET HMI request
9075	DisableAUX	Boolean BOOL			R	
9081	StartAutoModeTime	Signed 16-bit INT		HH:MM	RW	AUTO mode start time (from RTC)
9400	PACKED_Status01	Unsigned 16-bit WORD			R	Packed BOOL status variables (to optimize remote HMI communication) - Part 1
9401	PACKED_Status02	Unsigned 16-bit WORD			R	Packed BOOL status variables (to optimize remote HMI communication) - Part 2
9100	TelevisId	Signed 16-bit INT			R	Televis Identification
9101	Version1	Unsigned 16-bit UINT			R	Main Version
9102	Version2	Unsigned 16-bit UINT			R	Minor Version
9090	AlarmDOEnabled	Boolean BOOL			R	Ventilation fan DO configuration status (if TRUE, it is enabled)
9091	AlarmDO	0=Inactive; 1=Active BOOL			R	Ventilation fan DO
9134	ResetReqSMART	Boolean BOOL			RW	Reset thermal profile
9135	StartStopReqSMART	Boolean BOOL			RW	Start-Stop Program
9136	DisableReqSMART	Boolean BOOL			RW	Disable thermal profile
8971	HistoricalPosition	Unsigned 16-bit UINT			RW	
8972	Value_Historical_Code	Signed 16-bit INT			R	
8973	Value_Historical_Date	Signed 16-bit INT		XX.YY	R	

Address	ID	Values Device Type	Unit	Format	ReadOnly	Description
8974	Value_Historical_Time	Signed 16-bit INT		HH:MM	R	
8975	Value_Historical_V1	Signed 16-bit INT	°C	XXX.Y	R	
9082	Value_Historical_V2	Signed 16-bit INT	°C	XXX.Y	R	
9083	Value_Historical_V3	Signed 16-bit INT	%	XXX.Y	R	
9084	Historical_Number_alarms	Unsigned 16-bit UINT			R	
9085	Historical_alarms_Reset	Boolean BOOL			RW	Reset alarm history

ALPHABETICAL INDEX

A

access rights.....
 password..... 16
alarms.....
 alarm condition display..... 45
 high/low..... 46
 menu..... 13
 probe error..... 45
 reset..... 13
allarmi.....
 menu..... 14
analog input..... 19
analog output..... 21
automatic defrost..... 30

C

communication channels..... 21
compressor..... 24
 duty cycle..... 25
 protection in the event of probe failure..... 24
 relay..... 24
 safety times..... 25
cut-off regulator..... 36
 cut-off bypass time..... 36
 pre-ventilation..... 36
 start-up time..... 36

D

defrost..... 30
 defrost times menu..... 31
 FREE mode..... 33
 hot gas..... 33
 termination condition..... 32
 timeout..... 33
 with compressor stopped..... 32
 with electrical heaters..... 32
dehumidification.....
 relay..... 40
digital input..... 19
 polarity..... 20
 priority..... 20
digital output..... 20 e seg.
dripping..... 30

E

evaporator fans..... 34
 relay..... 34
 thermostat control..... 34

H

humidifier.....
 relay..... 39

K

keys..... 8
 associated functions..... 8

L

LED..... 9

M

manual defrost..... 31
menu Allarmi attivi..... 14
menu principale..... 10

P

parameters..... 49

menu..... 16, 49
table..... 58
parametri.....
 menu..... 17
 tabella..... 59
pressure switch..... 38
 alarm..... 38
 alarm reset..... 38
 event count..... 38
probes..... 19

R

references..... 6
relative humidity regulation..... 39
 dehumidification..... 39
 humidification..... 39
relay..... 20

T

thermal profiles..... 41
 menu..... 41
 program reset..... 43
 program run..... 42
 program start..... 42
 program STOP..... 42
 step..... 43
thermoregulation..... 27
 cooling..... 27
 heating..... 27
 mode selection from digital input..... 28
 neutral zone..... 28

V

ventilation fans..... 35
 duty cycle..... 35
 relay..... 35

..... 8 e seg.

