

Life Is On

**eliwell**<sup>TM</sup>  
by Schneider Electric

# FREE Way

The programmable platform



[www.eliwell.com](http://www.eliwell.com)



```
<div class="pinSocialMeta">
  <a class="socialItem"
href="pin/297026537901201080/repin", data-element-type="174">
  <em class="repinIconSmall"></em>
  <em class="socialMetaCount repinCountSmall">
  <a class="socialItem likes" href="pin/297026537901201080/like", da
  <em class="likeIconSmall"></em>
</div>
```



```
login
password
login logout
```

# FREE Way

The programmable platform



# General description

## The Eliwell programmable platform

**FREE Way** is the range of logic controllers developed by Eliwell, which consists of the **FREE Smart**, **FREE Panel**, **FREE Advance** and **FREE Evolution**.

**FREE Studio Plus** is the universal programming software for machines automated by the **FREE Way** logic controllers. It simplifies each of the steps in machine design and commissioning:

- 1 Unique, simple and flexible software suite software or the entire **FREE Way** range
- Compatible with the 5 standard programming languages (IEC 61131-3) to cover all needs with graphic or text languages
- Advanced debug and simulation options plus complete and effective online Help
- Tools for easy commissioning
- Advanced communication features such as remote control and download
- Webpage creation from the software

---

## Features

### FREE Smart

- User interface with configurable keys
- Available in three sizes, in the 100...240Vac and 12...24 Vac/ 24Vdc versions:
  - **FREE Smart SMP**, panel mount (32x74mm) with LED display
  - **FREE Smart SMD** 4 DIN with LED display, **FREE Smart SMC** 4 DIN blind
- Connectible via RS-485, Modbus RTU or Eliwell standard user interfaces and peripherals

### FREE Panel

- Available in two sizes:
  - **FREE Panel EVP** system controller, with gateway functions and monochrome backlit LCD display, available for panel mounting (**FREE Panel EVP**) or wall mounting
  - **FREE Panel AVP** one controller with backlit colour graphic touch display, for wall or panel mounting, with built-in temperature, humidity and presence sensors
- High connectivity: can be integrated in industrial systems and micro BMS
- Connectible with Eliwell standard and third-party peripherals

### FREE Advance

- Fully customizable graphic user interface
- Available in 4 Din and 8 Din sizes, **FREE Advance AVD** with backlit LCD graphic display, **FREE Advance AVC** blind
- High built-in connectivity as standard for integration in industrial systems and BMS
- Connects to standard Eliwell peripheral devices (including FREE Smart) to any network whatever it is Modbus SL, BACnet MS/TP, Modbus TCP, BACnet IP or LonWorks network
- A slot for a micro SD memory card that can be used for data logging or Webserver storage
- USB programming ports

### FREE Evolution

- Fully customizable graphic user interface
- Available in 8 Din FREE Evolution EVD sizes with backlit LCD graphic display and **FREE Evolution AVC** blind versions
- High connectivity: integrates into industrial systems and BMS using dedicated plug-in modules which allows to connect to BACnet MS/TP, Modbus TCP and BACnet IP networks
- Connects to standard Eliwell peripheral devices (including FREE Smart) and third party devices
- USB programming ports

Certification cULus depending on model, specified in UL reference file no. E233482

**AVP1100/1200/1300**: CTUVus certification indicated in UL reference file no. U8 17 05 54090 001

# Plus points



FREE Panel AVP



FREE Panel EVP



FREE Advance



FREE Evolution



FREE Smart

## Speed

One of the FREE programmable platform's main aims is to enable customers to create solutions for their customers fast. Many FREE features significantly cut the times between design of a new application and its production release.

## Compactness

The FREE programmable platform makes customers cost-competitive. FREE controllers were designed with a strong focus on technology and physical size, with impressive results in terms of simplicity, modularity and compactness. FREE controllers' integrated solutions and small size generate real, immediate financial savings for customers.

## Efficiency

Complete and scalable to different complexity levels, the FREE programmable platform gives customers great freedom to choose the solution they consider best for their application. This allows easy identification of solutions that cut costs or item numbers, facilitating solutions more open to future developments or future system demands, especially with regard to connectivity.

## Reliability

The FREE Way programmable platform's high quality standards enable customs to save on the costs generated by quality nonconformities both in their production processes and in installations in the field. **FREE Smart, FREE Panel, FREE Advance and FREE Evolution** controllers and the **FREE Studio Plus** development environment were all designed with innovative but carefully defined criteria, using state-of-the-art yet stable technology solutions and certified, monitored production processes. Eliwell has always been famed for its reliability.

---

## The FREE Way targets

### Constructors of:

- AHUs (Air Handling Units)
- Chillers
- Heat Pumps
- Rooftop Units
- Precision air-conditioners
- Compressor Rooms

### Installers/system integrators of:

- All-air systems
- Hydronic systems
- Air-water systems
- Commercial automation



# FREE Studio Plus

The **FREE Studio Plus** software suite is compatible with all 5 standard programming languages (**IEC61131-3**). Every project may comprise several programs; developers can use more than one language in the same project.

Every new program has a choice of 5 programming languages, 2 textual and 3 visual:

- **ST, Structured Text**
- **FBD, Functional Block Diagram**
- **LD, Ladder**
- **IL, Instruction List**
- **SFC, Sequential Function Chart**

## IEC61131-3 development software

### Main functions

#### Variable display with application running

Debugging of variables through display of their status in numerical format when the application is running and connected to FREE Smart, FREE Panel, FREE Advance and FREE Evolution

#### Function Library

Management of default and/or developer-created function libraries.  
Any additional cards are managed by the developer himself

#### Variable graphic display

Debugging of variables through display of their status in graphic format when the application is running and connected to FREE Smart, FREE Panel, FREE Advance and FREE Evolution

#### Variable reading / writing

The working environment allows:

- creation of a dedicated menu to be shown on the device's display
- reading and writing of BIOS parameters (parameters + I/O values)
- reading and writing of the parameters and variables defined by the developer in Applications associated to the menu

**On-line Help** to assist the programmer in every program development phase, accessed from the context by just pressing the F1 button.

The whole on-line help guide is also available in printable pdf format

**Baselines and Libraries**, ready to use and available for download via web

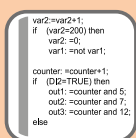

ST

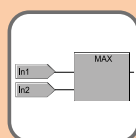

FBD

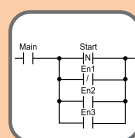

LD

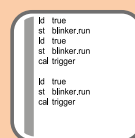

IL

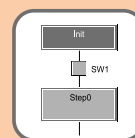

SFC



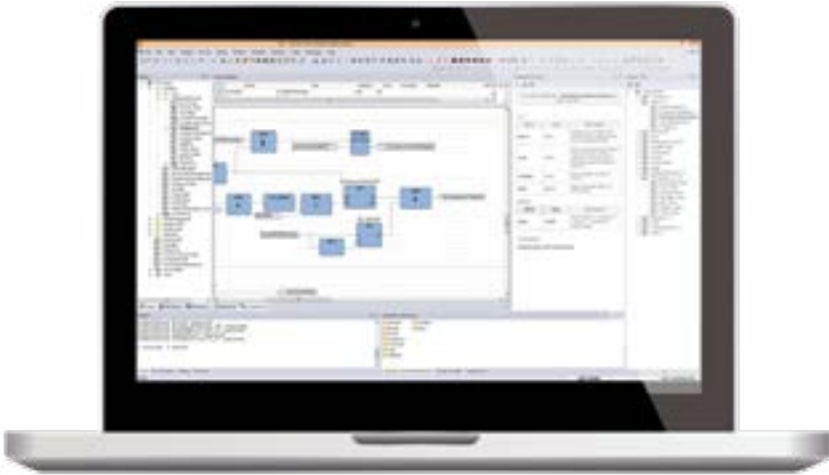

## Components

**FREE Studio Plus** is the universal programming software for machines automated by the **FREE Way** logic controllers. It simplifies each of the steps in machine design and commissioning:

**FREE Studio Plus** allows developers to program in various working environments, since they can access constantly updated with new functions and optimizations, available in the specific area of the Eliwell web site.

- 1 Unique, simple and flexible software suite software or the entire **FREE Way** range
- Compatible with the 5 standard programming languages (IEC 61131-3) to cover all needs with graphic or text languages
- Advanced debug and simulation options plus complete and effective online Help
- Tools for easy commissioning
- Advanced communication features such as remote control and download
- Webpage creation from the software
- Advanced communication features as remote control and download
- Webpage creation for the software



## Baselines

**Applications** supplied ready to use, compliant with architecture rules, easily modified to all requirements.

**Libraries** of objects to save you even more time, by making FREE Studio Plus easier to use.

---

## System and installation requirements

### Operating Systems

- Windows 10 English
- Windows 8, 8.1 English
- Windows 7 Home / Professional / Ultimate English

### Supported browser

- Internet Explorer 11 or greater

The installation setup, software updates, libraries and documentation are available on the [eliwell.com](http://eliwell.com) website, after registration for access to the private area.

# FREE Smart models

Models are available both DIN rail mount version (SMD with display, SMC without display) and in the 32x74 Eliwell standard version (SMP) panel mount version.

The offering is completed by various expansions (SME) and terminals (SKP, SKW) for combination with FREE Smart series models.

All inputs and outputs are independent and configurable to ensure adaptability to any system.



## FREE Smart 12...24 Vac / 24Vdc /C identifies units with RTC – Real Time Clock

Model	Code	Digital Outputs at hazardous voltage	TRIAC Outputs at hazardous voltage	O.C. outputs: PWM / PPM at safety extra low voltage (SELV)	Analog outputs 0-10 V at safety extra low voltage (SELV)	Digital Inputs voltage free	Analogue Inputs at safety extra low voltage (SELV)	O.C. Outputs	RS 485 built-in
<b>SMP5500/C/S</b>	SMP5500050450	5	-	2	3	6	5	1	yes
<b>SMP5500/C</b>	SMP5500010450	5	-	2	3	6	5	1	-
<b>SMD5500/C/S</b>	SMD5500050450	5	-	2	3	6	5	1	yes
<b>SMD5500/C</b>	SMD5500010450	5	-	2	3	6	5	1	-
<b>SMD3600/C/S</b>	SMD3600050450	3	2	1	3	6	5	1	yes
<b>SMC5500/C/S</b>	SMC5500050450	5	-	2	3	6	5	1	yes
<b>SMC5500/C</b>	SMC5500010450	5	-	2	3	6	5	1	-

### Expansions

<b>SME3200</b>	SME3200000400	3	-	2	-	6	3	1	-
<b>SME5500</b>	SME5500000450	5	-	2	3	6	5	1	-

## FREE Smart 100...240 Vac /C identifies units with RTC – Real Time Clock/S identifies units with built-in RS485 serial output

Model	Code	Digital Outputs at hazardous voltage	O.C. outputs: PWM / DI at safety extra low voltage (SELV)	Outputs 0...10 V at safety extra low voltage (SELV)	Outputs 4...20 mA / 0...20 mA	Analog inputs at safety extra low voltage (SELV)
<b>SMD4500/C/S</b>	SMD4500050H00	4	2	2	1	5
<b>SMD4500/C</b>	SMD4500010H00	4	2	2	1	5
<b>SMC4500/C/S</b>	SMC4500050H00	4	2	2	1	5

### Expansion

<b>SME4500</b>	SME4500000H00	4	2	2	1	5
----------------	---------------	---	---	---	---	---

## Terminals with power supply from base

Model	Code	Mount	Dimensions	Display	Analog inputs at safety extra low voltage (SELV)
<b>SKP10</b>	SKP100G000000	panel	74x32x30 mm	LED / 4 digits	-
<b>SKW22</b>	SKW220G000000	wall	137x96.5x31.3 mm	LCD	1 built-in NTC 1 NTC input / DI / 4...20 mA
<b>SKW22L</b>	SKW22LG000000	wall	137x96.5x31.3 mm	Backlit LCD	1 built-in NTC 1 NTC input / DI / 4...20 mA
<b>SKP22</b>	SKP220G000000	panel; wall: see Accessories page	160x96x10 mm	LCD	1 NTC input 1 NTC input / DI / 4...20 mA

KEY: SELV = Safety Extra Low Voltage; PPM = Pulse Position Modulation; PWM = Pulse Width Modulation; O.C. = Open Collector

### Available resources - FREE Smart (model /C/S, msk 412)

The IEC programmer has the following resources:

<b>CPU</b>	14.7 MHz
memory available for <b>Application</b>	190 Kbytes
RAM - automatic mapping	2300 Bytes
RAM - Modbus mapping	1024 Byte
EEPROM variables	1024 Byte

### Minimum developer kit - FREE Smart

- FREE Studio Plus installation setup
  - 1 FREE Smart SMxxxx\*
  - 1 DMI 100-3 Manufacturer + yellow TTL cable
  - 1 MFK optional + blue TTL cable
  - FREE Smart\* power supply wiring and transformer
- \* otherwise, order the Demo Case





# FREE Smart connectivity

FREE Smart controllers are equipped with a serial port for easy integration with the supervision systems of the installation plant.

All controller resources can be accessed via standard Modbus communication protocol, guaranteeing complete control of the plant.

All models have TTL port as standard; /S models have built-in RS485 serial port.

A special Firmware version also provides the Modbus MASTER function.

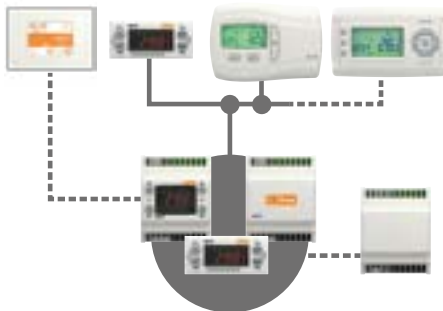

## FREE Smart maximum configuration

- max 1 FREE Smart model
- max 1 SME expansion by LAN serial line
- max 1 SKP10 terminal with controller ECHO function
- max 1 SKW22(L) or SKP22 terminal with dedicated menu, allowing ambient temperature and humidity monitoring
- LAN maximum distance: 100 m

## FREE Smart update function

Multi Function Key (MFK 100) for uploading and downloading parameter map for quick configuration, and uploading the IEC application and BIOS.

### Multi Function Key / DMI

PC → ← FREE

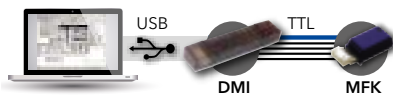

use **blue TTL cable** for DMI - MFK connection

Data download direction	→	←
Parameter map	-	-
IEC application	✓	-
BIOS	✓	-

### Multi Function Key

MFK → ← FREE

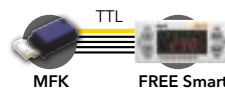

use **yellow TTL cable** for MFK - target connection

Data download direction	→	←
Parameter map	✓	✓
IEC application	✓	-
BIOS	✓	-

### Network

PC → ← FREE

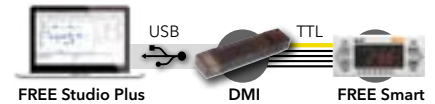

use **yellow TTL cable** for DMI - target connection

Data download direction	→	←
Parameter map	✓	✓
IEC application	✓	-
BIOS	✓	-

## Modbus Slave or Master mode connection examples

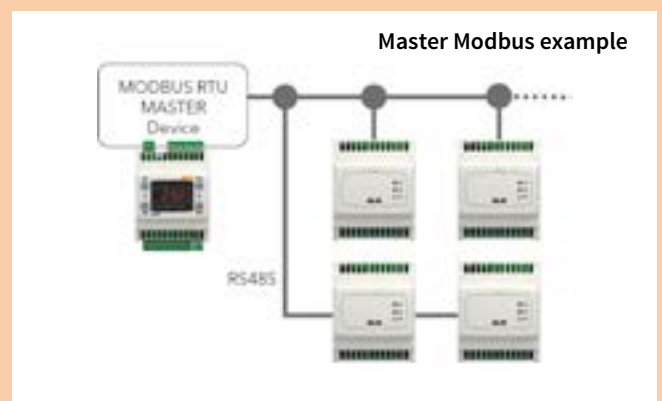
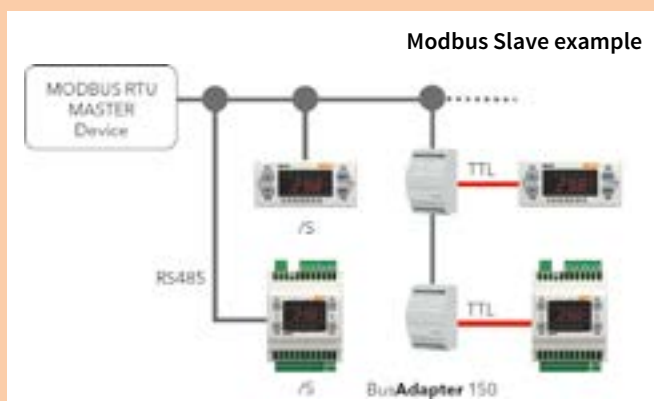

For models without RS485 use only BusAdapter 150



# SMP, SMD, SMC5500



SMP5500



SMD5500



SMC5500

## Technical data

	SMP5500	SMD5500	SMC5500
<b>size</b>	32x74x80 mm (Lxhxd)		4DIN
<b>display</b>	LED 4 digit - 7 segments		-
<b>power supply</b>	12...24 Vac / 24 Vdc		
<b>relay digital outputs</b>	5 x 2 A 250 Vac		
<b>analog outputs</b>	2 x O.C. PPM/PWM 3 x 0...10 V		
<b>O.C. digital outputs</b>	1 Open Collector		
<b>digital inputs</b>	6 voltage free		
<b>analog inputs</b>	3 x NTC / D.I. 2 x NTC / D.I. / 0...20 mA / 4...20 mA / 0-10 V / 0-5 V / 0-1 V		
<b>connectivity</b>	TTL RS485 isolated (only /S models) LAN for connection to SKP/SKW terminal or SME expansion		
<b>operating temperature</b>	-20...+55 °C		

## Electric, mount and dimensional diagrams

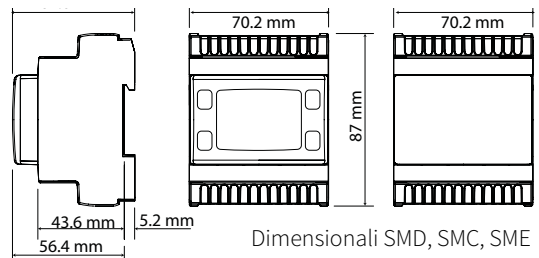
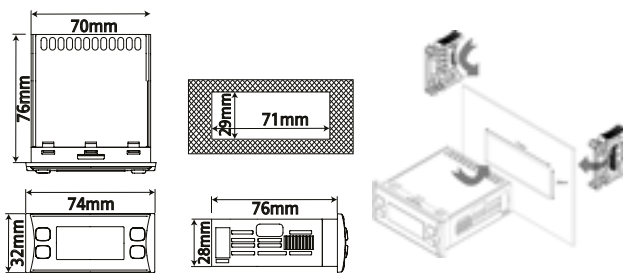

Dimensional SMD, SMC, SME

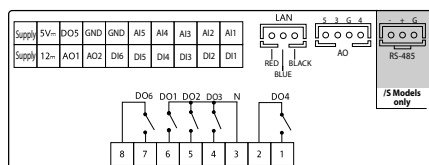

SMP5500/C - SMP5500/C/S

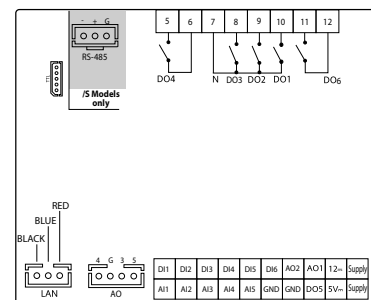

SMD5500/C/S - SMC 5500/C - SMC5500/C/S

# SMD3600, SME Expansions



SMD3600



SME3200



SME5500

## Technical data

	SMD3600	SME3200	SME5500
<b>size</b>		4DIN	
<b>display</b>	LED 4 digit - 7 segments	-	-
<b>power supply</b>	12...24 Vac	12...24 Vac / 24 Vdc	
<b>relay digital outputs</b>	3 x 2A 250 Vac		5 x 2A 250 Vac
<b>analog outputs</b>	2 x TRIAC 3 A 250 Vac 1 x Open Collector PPM/PWM 3 x 0...10 V	1 x Open Collector PPM/PWM -	1 x Open Collector PPM/PWM 3 x 0...10 V
<b>O.C. digital outputs</b>	2 Open Collector	1 Open Collector	
<b>digital inputs</b>	6 voltage free		
<b>analog inputs</b>	3 x NTC / D.I. 2 x NTC / D.I. / 0...20 mA / 4...20 mA / 0-10 V / 0-5 V / 0-1 V	3 x NTC / D.I. -	3 x NTC / D.I. 2 x NTC / D.I. / 0...20 mA / 4...20 mA / 0-10 V / 0-5 V / 0-1 V
<b>connectivity</b>	TTL RS485 isolated LAN for connection to SKP/SKW terminal or SME expansion	TTL -	TTL -
<b>operating temperature</b>	-20...+55 °C		

## Electric diagrams

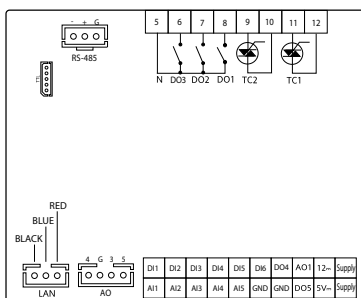

SMD3600/C/S

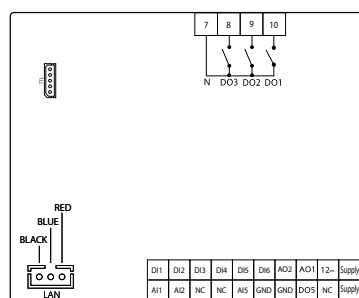

SME3200

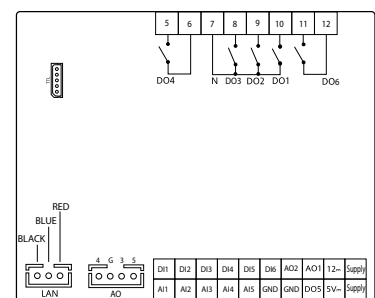

SME5500

# SMD, SMC4500, SME4500 Expansion



SMD4500



SMC4500



SME4500

## Technical data

	SMD4500	SMC4500	SME4500
<b>size</b>	4DIN		
<b>display</b>	LED 4 digit - 7 segments	-	-
<b>power supply</b>	100...240 Vac		
<b>relay digital outputs</b>	4 x 2 A 250 Vac		
<b>analog outputs</b>	2 x Open Collector PWM/D.I. 2 x 0...10 V 1 x 4...20 mA / 0...20 mA		
<b>analog inputs</b>	3 x NTC / Pt1000 / D.I. 2 x NTC / D.I. / 0...20 mA / 4...20 mA / 0-10 V / 0-5 V / 0-1 V		3 x NTC / D.I. 2 x NTC / D.I. / 0...20 mA / 4...20 mA / 0-10 V / 0-5 V / 0-1 V
<b>connectivity</b>	TTL RS485 LAN for connection to SKP/SKW terminal or SME expansion		TTL - LAN for connection to FREE Smart
<b>operating temperature</b>	-20...+55 °C		

## Electric diagrams

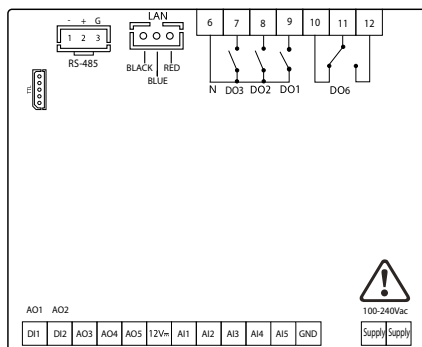

SMD4500/C/S - SMC4500/C/S

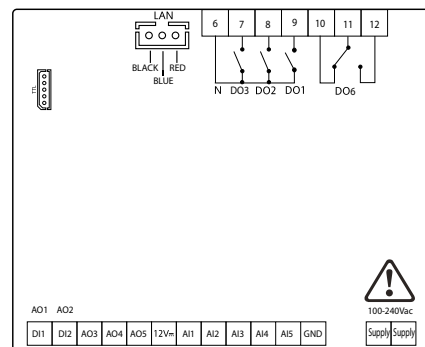

SME4500 Expansion

# Interfaces, FREE Smart Terminals



SKP10



SKW22/22L



SKP22

## Technical data

	SKP10	SKW22 - SKW22L	SKP22
<b>size (LxDxH)</b>	74x32x30 mm	4DIN	
<b>mount</b>	panel	wall	panel
<b>display</b>	LED 4 digit - 7 segments	LCD (model 22L: Backlit LCD)	LCD
<b>power supply</b>	from base		
<b>analog inputs</b>	- -	1 x built-in NTC 1 x NTC / D.I. / 0...20 mA / 4...20 mA remote	1 x remote NTC 1 x NTC / D.I. / 0...20 mA / 4...20 mA remote
<b>connectivity</b>	LAN for connection to FREE Smart		
<b>wiring</b>	COLV000033200 cable included in pack		
<b>operating temperature</b>	-20...+55 °C	-5...+60 °C	
<b>humidity module</b>	-	KP100000 - not included (see Accessories page)	-

## Electric and mount diagrams

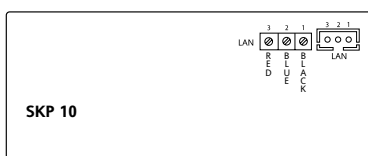
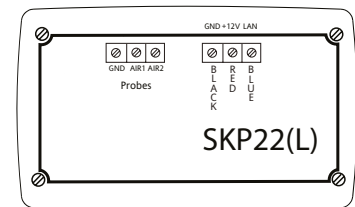
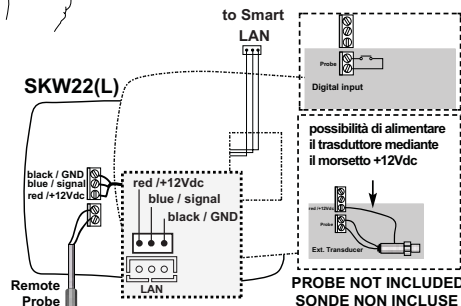
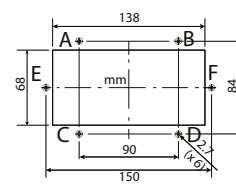
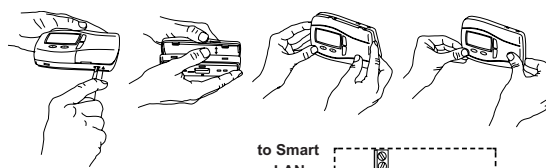
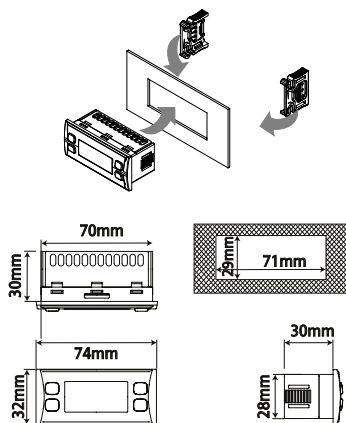

SKP10

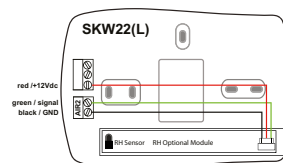

SKW22 - SWK22L

SKP22

# FREE Panel models

**FREE Panel AVP** is the completely customizable solution for creating an easily maintained and serviced zone controller with backlit color graphic touchscreen display, mounting on vertical surfaces, Modbus Slave connectivity, and integral temperature, humidity and presence probes.

The panel version adds Modbus Master connectivity with option of installation inside a machine, also on DIN rail.



FREE Panel AVP

**FREE Panel EVP** is the version with LCD graphic display suitable for use as system controller, with gateway functions, used in association with the other FREE Advance, FREE Evolution and FREE Smart controllers or third party devices.

FREE Panel EVP delivers excellent performance in terms of memory, user interface, Master/Slave connectivity and expandability (up to 7 expansions via field CANbus), and is easy to program, maintain and service.

A special base plate is available as wall mount accessory.



FREE Panel EVP

FREE Panel AVP /C identifies units with RTC – Real Time Clock /P identifies panel mount						
Model	Code	Mount	Display	Built-in probe	Serial	
<b>AVP1000 /P WHITE</b>	AVP100W0P0500	panel*	color touchscreen display 3.5" 320x240	-	RS485** - Modbus SL USB Micro-B	
<b>AVP1000 /P GREY</b>	AVP100G0P0500	panel*	color touchscreen display 3.5" 320x240	-	RS485** - Modbus SL USB Micro-B	
<b>AVP1100 /C</b>	AVP11000W0500	wall***	color touchscreen display 3.5" 320x240	temperature	RS485** - Modbus SL USB Micro-B	
<b>AVP1200 /C</b>	AVP12000W0500	wall***	color touchscreen display 3.5" 320x240	temperature & relative humidity	RS485** - Modbus SL USB Micro-B	
<b>AVP1300 /C</b>	AVP13000W0500	wall***	color touchscreen display 3.5" 320x240	temperature, relative humidity and presence	RS485** - Modbus SL USB Micro-B	

\*both horizontal and vertical (for vertical surface mount see Accessories page)

\*\*RS485 Master or Slave

\*\*\*Vertical mount. Horizontal mount if built-in probes are not used.

FREE Panel EVP /C identifies units with RTC – Real Time Clock /RH: humidity probe					
Model	Code	Mount	Display	Inputs at safety extra low voltage (SELV)	Serial
<b>EVP3300/C</b>	EVP3300010B00	panel*	Backlit LCD	1 x built-in NTC; 1 x remote NTC; 1 x remote 4...20 mA / 0-5 V / 0-10 V	CANbus; RS485; Ethernet
<b>EVP3500/C/RH</b>	EVP3500010B00	panel*	Backlit LCD	1 x built-in NTC; 1 x remote NTC 1 x built-in %RH	CANbus; RS485; Ethernet

\*(for wall mount see Accessories page)

KEY: SELV = Safety Extra Low Voltage

## Available resources - FREE Panel

The IEC programmer has the following resources:

	FREE PANEL AVP	FREE PANEL EVP
<b>CPU</b>	120 MHz, 132 kB RAM	72 MHz, 32 Mbyte RAM
memory available for <b>Application + User Interface</b>	736 Kbytes	1 Mbyte + 1.5 Mbyte = 2.5 Mbyte
FLASH data memory	4 Mbyte (images + font)	128 Mbyte
RAM - automatic mapping for <b>Application + User Interface</b>	78 Kbyte	512 Kbyte + 512 Kbyte
RAM - Modbus mapping	5000 words	5000 words
EEPROM variables	4000 words (application)	4000 words (application) + 10000 words (BACnet objects)

# FREE Panel connectivity

## AVP

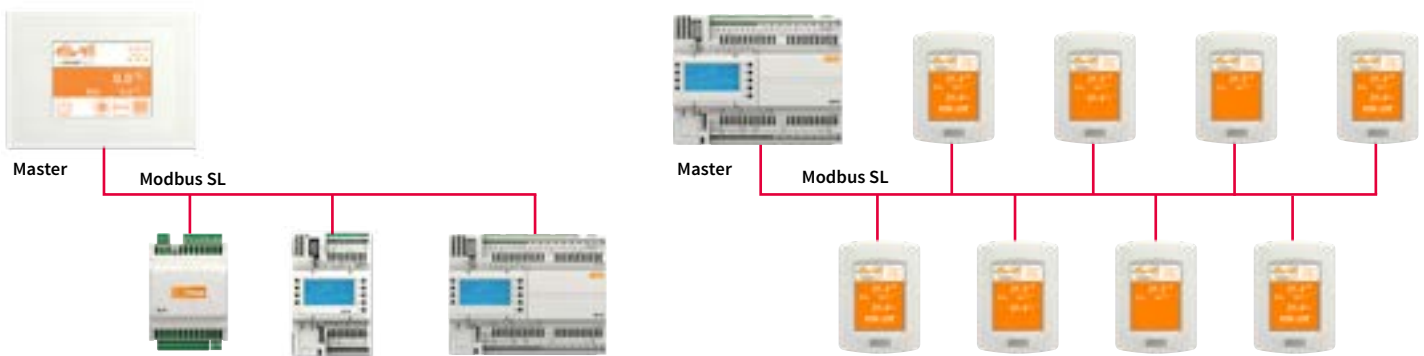

## EVP

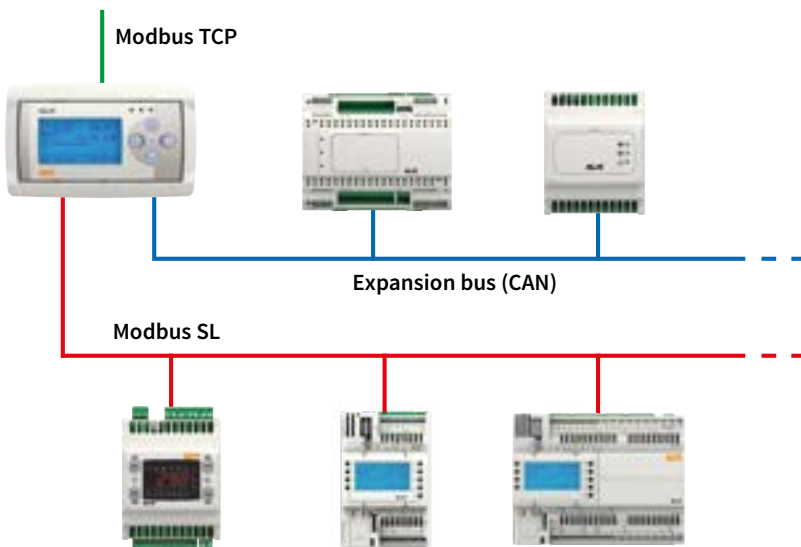

### Connectivity and functions

FREE Panel AVP delivers excellent performance in terms of memory, color user interface with resistive touchscreen display and Modbus Master/Slave connectivity, and is easy to program, maintain and service.

FREE Panel EVP delivers excellent performance in terms of memory, user interface, Master/Slave connectivity and expandability (up to 7 expansions via field CANbus), and is easy to program, maintain and service.

#### USB-RS485; Ethernet PC → ← FREE

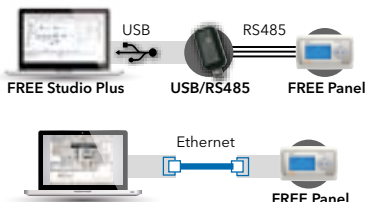

Data download direction	→	←
Parameter map	✓	✓
IEC application	✓	-
HMI application	✓	-
Data files	✓	✓
BIOS	✓	-
Commissioning	✓	✓

#### USB Host PC → ← FREE

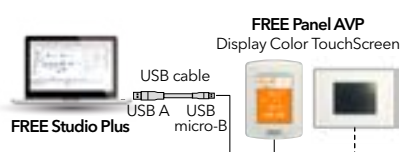

Data download direction	→	←
Parameter map	✓	✓
IEC application	✓	-
HMI application	✓	-
Data files	-	-
BIOS	✓	-

#### Ethernet PC → ← FREE

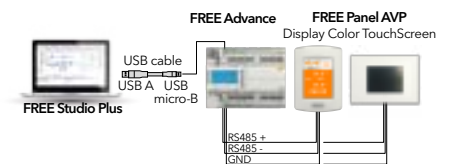

Configuration permissible with FREE Advanced in Bridge mode and AVP in Slave mode

Data download direction	→	←
Parameter map	✓	✓
IEC application	✓	-
HMI application	✓	-
Data files	-	-
BIOS	✓	-

# AVP1000



AVP1000/P WHITE



AVP1000/P GREY

## Technical data

	AVP1000/P WHITE	AVP1000/P GREY
<b>size</b>	134x96x35 mm	
<b>enclosure rating</b>	IP 65 on front panel	
<b>display</b>	color touchscreen display 3.5" 320x240	
<b>power supply</b>	24 Vac/dc (Type T 500 mA UL recognized fuse)	
<b>analog inputs</b>	none	
<b>connectivity</b>	RS 485 – Modbus SL USB Micro-B (programming and debug)	
<b>operating temperature</b>	-20...60 °C	

## Dimensional and mount diagrams

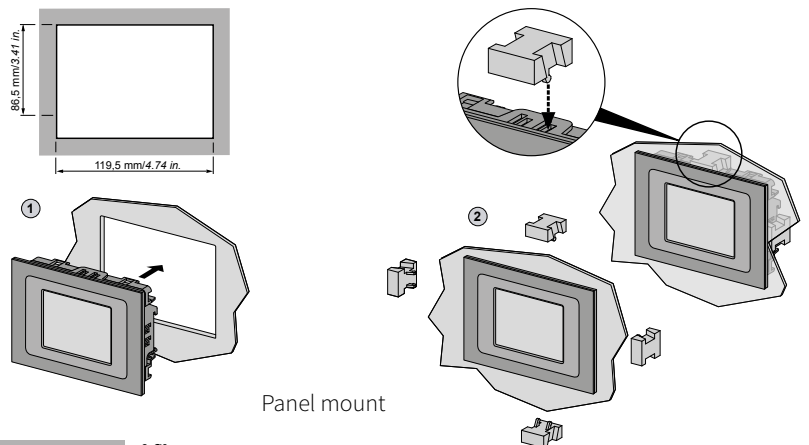
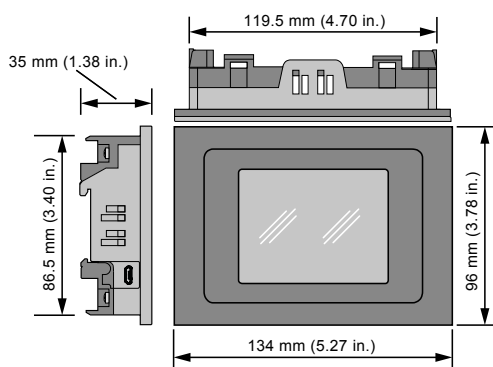

Panel mount

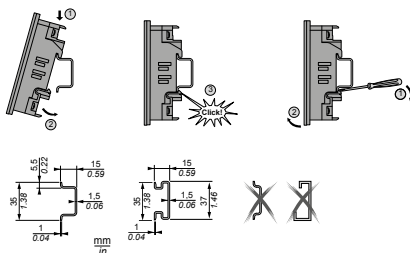

DIN rail mount

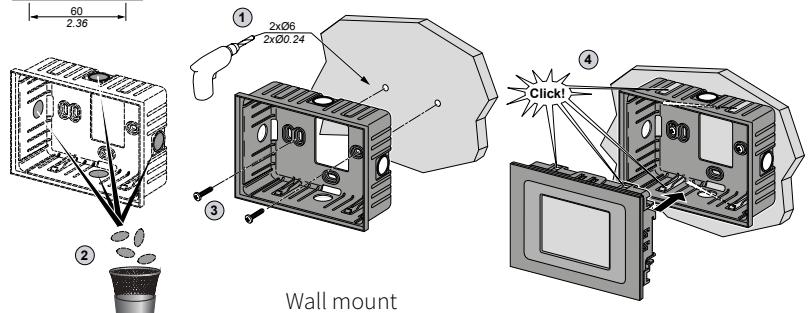
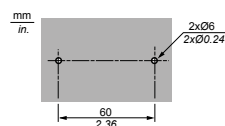

Wall mount



# AVP1100, AVP1200, AVP1300



AVP1100/C



AVP1200/C



AVP1300/C

## Technical data

	AVP1100/C	AVP1200/C	AVP1300/C
<b>size</b>	120x86x25 mm		
<b>display</b>	color touchscreen display 3.5" 320x240		
<b>power supply</b>	24 Vac/dc		
<b>analog inputs</b>	1 x built-in NTC	1 x built-in NTC 1 x built-in %RH	1 x built-in NTC 1 x built-in %RH 1 x built-in PIR (presence probe)
<b>connectivity</b>	RS485 - Modbus SL USB Micro-B (programming and debug)		
<b>operating temperature</b>	0...+50 °C		

## Electric and mount diagrams

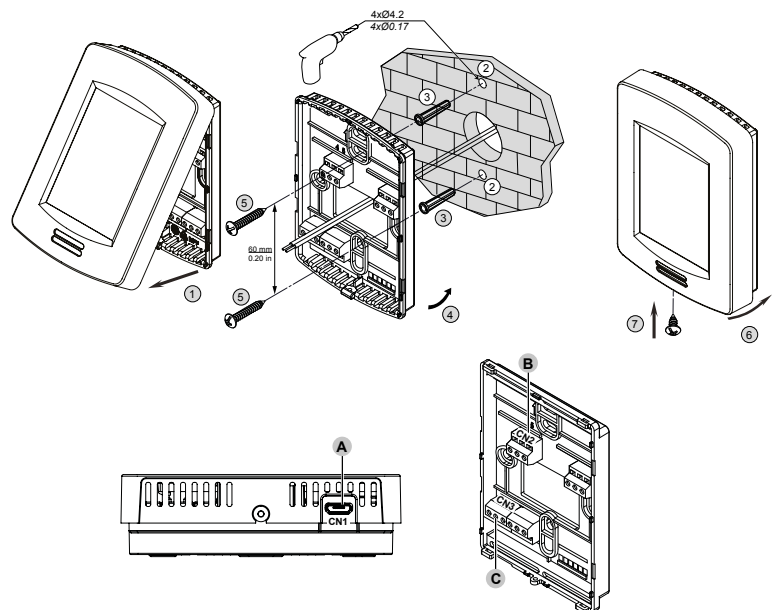
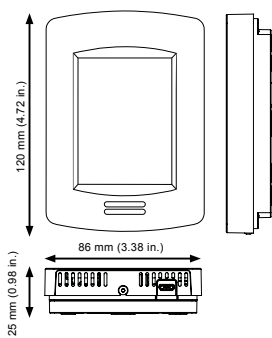

# EVP3300/C, EVP3500/C/RH



EVP3300/C



EVP3300/C/RH

## Technical data

	EVP3300/C	EVP3500/C/RH
<b>size</b>	160x96x10 mm	
<b>display</b>	backlit LCD 128x64 px graphic display	
<b>power supply</b>	24 Vac/dc - 48 Vdc isolated	
<b>analog inputs</b>	AI1 1 x built-in NTC AI2 1 x remote NTC / D.I. AI3 1 x remote 4...20 mA / 0-5 V / 0-10 V	AI1 1 x built-in NTC AI2 1 x remote NTC / D.I. AI4 1 x built-in %RH
<b>connectivity</b>	CANBus isolated: CANopen RS485 isolated: Modbus RTU, BACnet MSTP Ethernet: Modbus TCP - BACnet IP - WebServer	
<b>operating temperature</b>	-5...+55 °C	

## Electric and mount diagrams

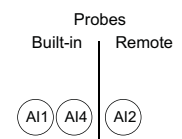
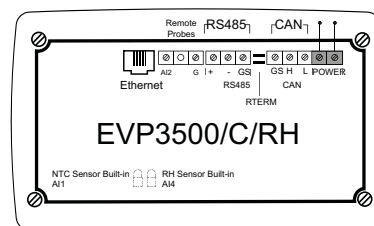
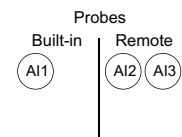
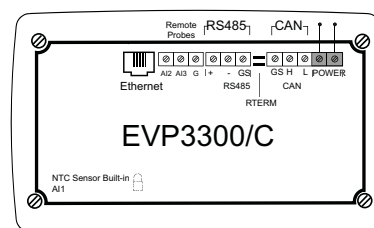
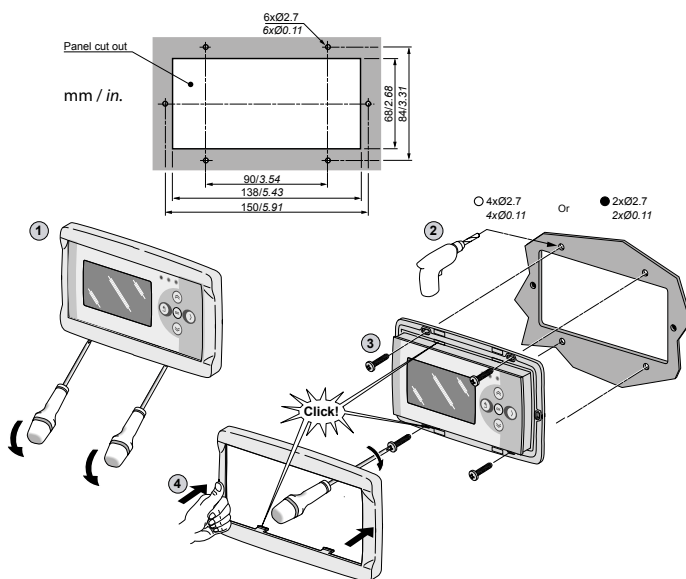

EVP3300/C - EVP3300/C/RH

# FREE Advance models



FREE Advance

**FREE Advance** models (**AVD** with display, **AVC** without display) are available in versions for assembly on 8 DIN rail, with disconnectable screw terminal blocks for quick, easy installation.

Every AVD or AVC is expandable via CANbus (field) up to 7 expansions and 2 terminals (EVK). Up to 10 controllers can also be connected together via CANbus (network).

Up to 127 devices can be controlled with Modbus Master, via RS485.

## FREE Advance with or without display /C indicates units with RTC – Real Time Clock; built-in RS485 and CANbus as standard

Model	Code		Relay outputs at hazardous voltage	SSR outputs	Analog outputs at safety extra low voltage (SELV)	Digital inputs (SELV) 2 fast pulse/frequency counters up to 2 KHz included	Analog inputs at safety extra low voltage (SELV)
<b>AVD3000/C/L/U</b>	AVD3000060500	Isolated	3	-	-	2	2
<b>AVC3000/C/L/U</b>	AVC3000060500	Isolated	3	-	-	2	2
<b>AVD6200/C</b>	AVD6200050500	Isolated	6	-	2	2	8
<b>AVC6200/C</b>	AVC6200050500	Isolated	6	-	2	2	8
<b>AVD6200/C/L/U</b>	AVD6200060500	Isolated	6	-	2	2	8
<b>AVD6200/C/L/U/SSR</b>	AVD62SS060500	Isolated	4	2	2	2	8
<b>AVC6200/C/L/U</b>	AVC6200060500	Isolated	6	-	2	2	8
<b>AVC8400/C/L/U</b>	AVC8400060500		8	-	4	8	8
<b>AVD8400/C/L/U</b>	AVD8400060500		8	-	4	8	8
<b>AVD8400/C/L/U/SSR</b>	AVD84SS060500		6	2	4	8	8
<b>AVC12600/C/L/U</b>	AVC1260060500		12	-	6	12	12
<b>AVD12600/C/L/U</b>	AVD1260060500		12	-	6	12	12
<b>AVD12600/C/L/U/SSR</b>	AVD126S060500		10	2	6	12	12
<b>AVC8400/C/L/U/I</b>	AVC840006I500	Isolated	8	-	4	8	8
<b>AVD8400/C/L/U/I</b>	AVD840006I500	Isolated	8	-	4	8	8
<b>AVD8400/C/L/U/SSR/I</b>	AVD840006I500	Isolated	6	2	4	8	8
<b>AVC12600/C/L/U/I</b>	AVC126006I500	Isolated	12	-	6	12	12
<b>AVD12600/C/L/U/I</b>	AVD126006I500	Isolated	12	-	6	12	12
<b>AVD12600/C/L/U/SSR/I</b>	AVD126006I500	Isolated	10	2	6	12	12
<b>AVC8400/C/I</b>	AVC840005I500	Isolated	8	-	4	8	8
<b>AVD8400/C/I</b>	AVD840005I500	Isolated	8	-	4	8	8
<b>AVC12600/C/I</b>	AVC126005I500	Isolated	12	-	6	12	12
<b>AVD12600/C/I</b>	AVD126005I500	Isolated	12	-	6	12	12

## Expansions RS485 (EVE7500 only) and built-in CANbus as standard

Model	Code	Relay outputs at hazardous voltage	SSR outputs	Analog outputs (SELV) <b>AO4/AO5</b> configurable as Open Collector 12 Vdc 100 mA max each	Digital inputs at safety extra low voltage (SELV)	Digital inputs voltage free	Analog inputs at safety extra low voltage (SELV)
<b>EVE10200</b>	EVE1020000500	10	-	2 (AO1/AO2 30 mA)	4+2**	-	10
<b>EVE4200</b>	EVE4200000500	4	-	2 (AO1/AO2 30 mA)	4	-	4

FREE Advance controllers are compatible also with EVE7500

\*fast pulse/frequency counter 1 KHz

\*\*fast pulse/frequency counter 2 KHz

### Minimum developer kit

- FREE Studio Plus installation setup
- 1 FREE Advance AVD8400/C/L/U
- Mini USB cable for connection to PC
- Ethernet cable for network connection
- FREE Advance power supply transformer

**Available resources:** The IEC programmer has the following resources:

<b>CPU</b>	120 MHz 16 MByte RAM	RAM - automatic mapping for <b>Application</b> and <b>User Interface</b>	512 kByte + 512 kByte
memory available for <b>Application</b>	1 MByte	RAM - Modbus mapping	5000 words
memory available for <b>User Interface</b>	1.5 MByte	EEPROM variables	4000 words (application) + 10000 words (BACnet objects)
FLASH data memory	6 MByte		

# FREE Advance connectivity

**FREE Advance** models are equipped with ETHERNET and RS-485 serial ports and built-in CANBUS as standard. They can also be integrated in industrial systems and BMS via the range of plug-in units, 2DIN modules quickly and easily connected to the AVD/AVC module.

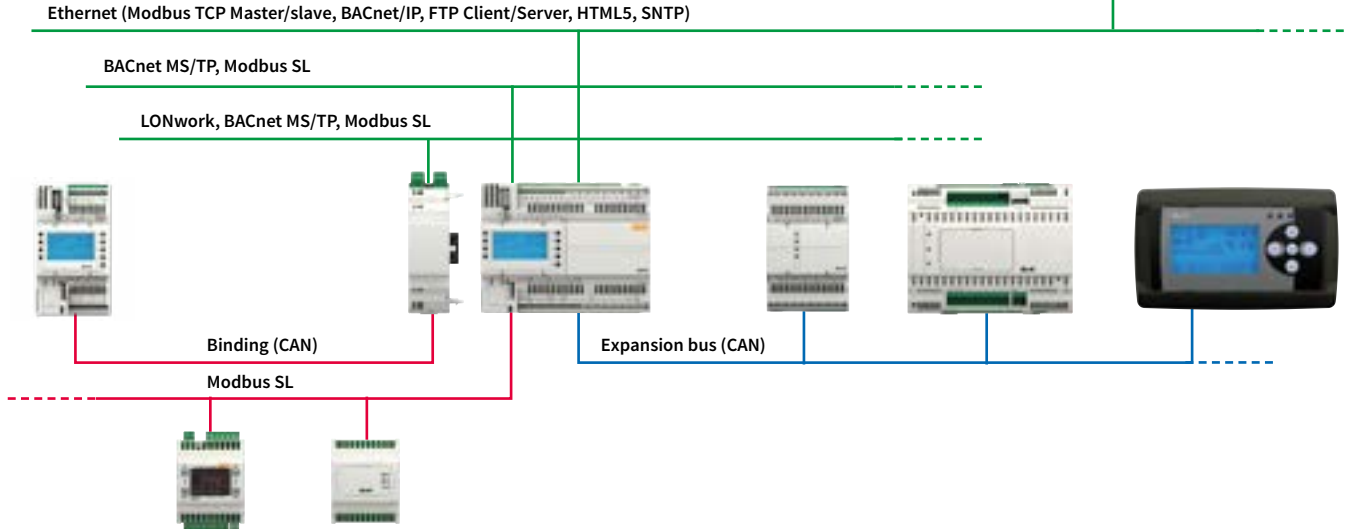

## Connectivity and functions

FREE Advance controllers feature integrated advanced functions, since they incorporate the Ethernet, BACnet, FTP and SNMP protocols as standard, as well as the LON protocol via an optional plug-in.

The Internet connection and integral WebServer offer machine constructors and system integrators complete remote access, drastically reducing service and maintenance times.

This also benefits end users, who can control their plants from multiple devices.

- Integral WebServer
- Local and remote plant control, including email alarm and alert management
- Remote reading and assistance
- Preventive and predictive maintenance
- State-of-the-art plant interface on PC, Tablet and Smartphone

### SD card Datalogging SD card → ← FREE

#### FREE Advance



Data download direction	→	←
Parameter map	-	-
IEC application	✓	
HMI application		
Data files	✓	✓
BIOS	-	-

### USB Host PC → ← FREE

#### FREE Advance



Data download direction	→	←
Parameter map	✓	✓
IEC application	✓	✓
HMI application	✓	✓
Data files	✓	✓
BIOS	✓	-

### Ethernet / USB Device / RS485 PC → ← FREE

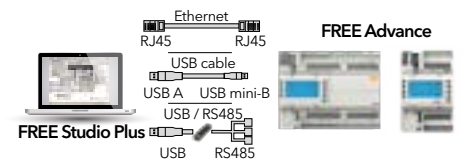

Data download direction	→	←
Parameter map	✓	✓
IEC application	✓	-
HMI application	✓	-
Data files	✓	✓
BIOS	✓	-

# AVD3000/C/L/U, AVC3000/C/L/U



AVD3000



AVC3000

## Technical data

	AVD3000	AVC3000
size	4 DIN	
display	backlit LCD 128x64 pixel graphic display	-
power supply	24 Vac isolated 20...38 Vdc isolated	
digital outputs	3: 3 x 3 A 250 Vac	3: 3 x 3 A 250 Vac
digital inputs	2 x SELV can operate as pulse/frequency counters up to 2 kHz	
analog inputs	2 x NTC 103AT / NTC NK103 / D.I. / PTC KTY81 / Pt1000 / 0...20 mA / 4...20 mA / 0-10 V / 0-5 V	
connectivity	Ethernet: Bacnet IP, Modbus TCP Master/Slave, Webserver, Ftp Client/Server, SNTp CANBus: CANopen 2 x RS485: Modbus RTU (of which 1 x RS485: also BACnet MS/TP) USB (type A); USB (type mini-B)	
operating temperature	-20...+60°C	

## Electric and mount diagrams

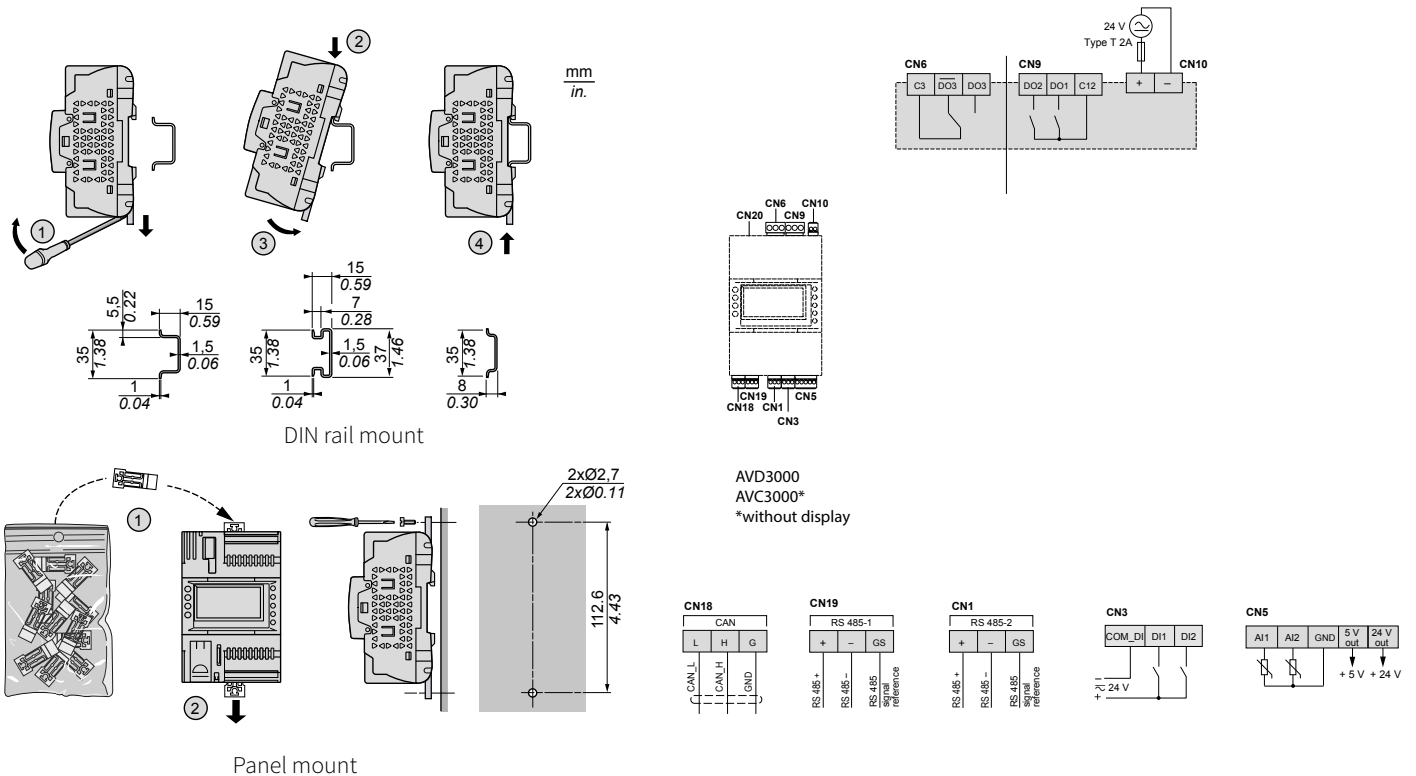

# AVD6200/C, AVC6200/C



AVD6200/C



AVC6200/C

## Technical data

	AVD6200/C	AVC6200/C
<b>size</b>	4 DIN	
<b>display</b>	backlit LCD 128x64 pixel graphic display	-
<b>power supply</b>	24 Vac isolated 20...38 Vdc isolated	
<b>digital outputs</b>	6: 6 x 3 A 250 Vac	6: 6 x 3 A 250 Vac
<b>analog outputs</b>	2: 2 x 0-10 V, 2 x 0-10 V / 4...20 mA / ON-OFF / PWM / O.C. 24 Vdc 50 mA max	
<b>digital inputs</b>	2 x SELV can operate as pulse/frequency counters up to 2 kHz	
<b>analog inputs</b>	8 x NTC C 103 AT / NTC NK103 / D.I. / PTC KTY81 / Pt1000 / 0...20 mA / 4...20 mA / 0-10 V / 0-5 V	
<b>connectivity</b>	CANBus: CANopen 2 x RS485: Modbus RTU (of which 1 x RS485: also BACnet MS/TP) USB (type mini-B); 1 x plug-in EVS: Ethernet: BACnet IP, Modbus TCP Master/Slave, Webserver, Ftp Client/Server, SNMP via specific EVS ETH plug-in module	
<b>operating temperature</b>	-20...+60 °C	

## Electric and mount diagrams

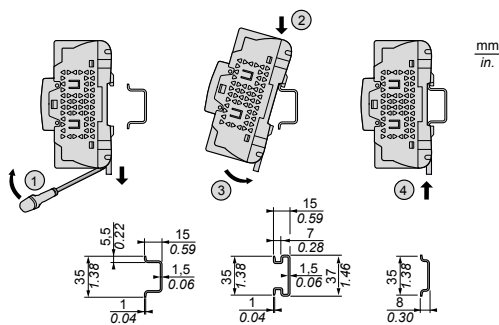

DIN rail mount

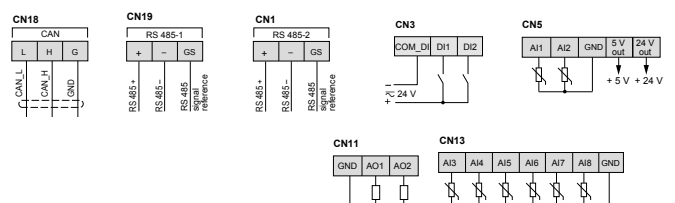
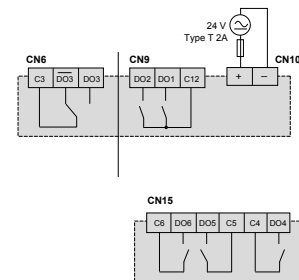
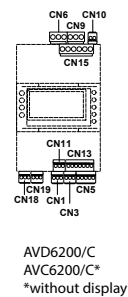
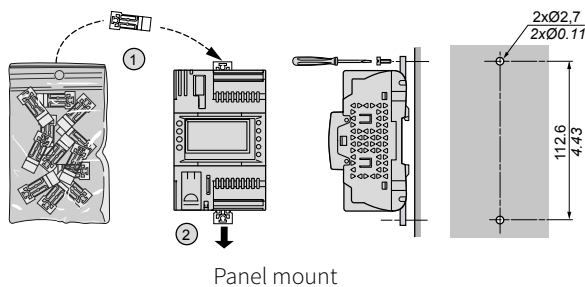

# AVD6200/C/L/U, AVD6200/C/L/U SSR, AVC6200/C/L/U



AVD6200/C/L/U



AVD6200/C/L/U SSR



AVC6200/C/L/U

## Technical data

	AVD6200/C/L/U	AVD6200/C/L/U SSR	AVC6200/C/L/U
<b>size</b>	4 DIN		
<b>display</b>	backlit LCD 128x64 pixel graphic display		-
<b>power supply</b>	24 Vac isolated 20...38 Vdc isolated		
<b>digital outputs</b>	<b>6:</b> 6 x 3 A 250 Vac	<b>4:</b> 4 x 3 A 250 Vac <b>SSR:</b> 2 x 0.2A 240 Vac	<b>6:</b> 6 x 3 A 250 Vac
<b>analog outputs</b>	<b>2:</b> 2 x 0-10 V, 2 x 0-10 V / 4...20 mA / ON-OFF / PWM / O.C. 24 Vdc 50 mA max		
<b>digital inputs</b>	<b>2 x SELV</b> can operate as pulse/frequency counters up to 2 kHz		
<b>analog inputs</b>	<b>12 x</b> NTC 103 AT / NTC NK103 / D.I. / PTC KTY81 / Pt1000 / 0...20 mA / 4...20 mA / 0-10 V / 0-5 V		
<b>connectivity</b>	Ethernet: Bacnet IP, Modbus TCP Master/Slave, Webserver, Ftp Client/Server, SNMP CANBus: CANopen 2 x RS485: Modbus RTU (of which 1 x RS485: also BACnet MS/TP) USB (type A); USB (type mini-B); 1 x plug-in EVS		
<b>operating temperature</b>	-20...+60 °C	-20...+55 °C	-20...+60 °C

## Electric and mount diagrams

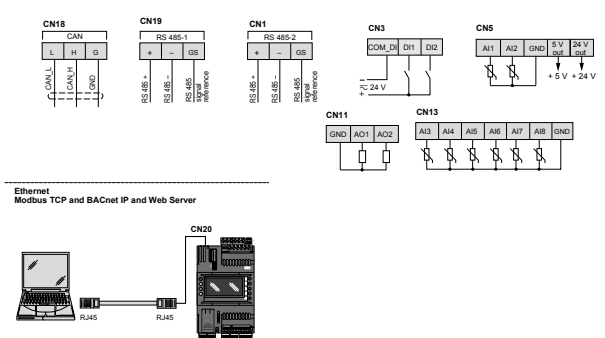
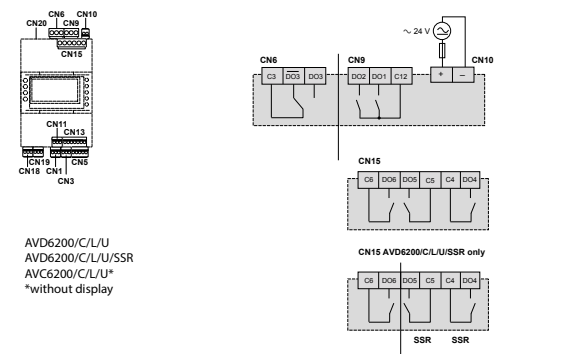
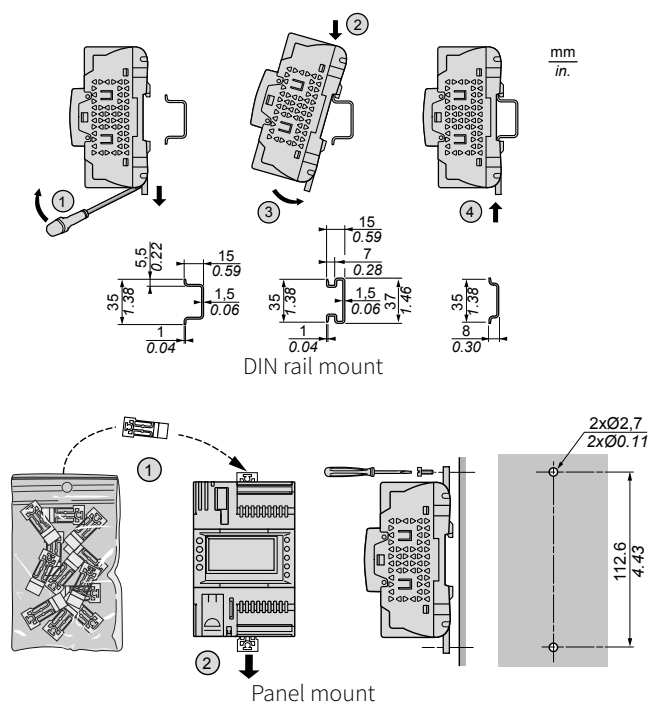

# AVD8400, AVD8400 SSR, AVC8400 /C/L/U (/I)models



AVD8400



AVD8400 SSR



AVC8400

## Technical data

	AVD8400	AVD8400 SSR	AVC8400
<b>size</b>	8 DIN		
<b>display</b>	backlit LCD 128x64 pixel graphic display		
<b>power supply</b>	24 Vac (isolated, /I models only) 20...38 Vdc (isolated, /I models only)		
<b>digital outputs</b>	8: 7 x 3 A, 1 x 1A 250 Vac	6: 5 x 3 A, 1 x 1 A 250 Vac SSR: 2 x 0.5 A 240 Vac	8: 7 x 3 A, 1 x 1 A 250 Vac
<b>analog outputs</b>	4: 2 x 0-10 V, 2 x 0-10 V /4...20 mA / ON-OFF / PWM / O.C. 24 Vdc 30 mA max		
<b>digital inputs</b>	6 x SELV 2 x pulse/frequency counters up to 2 kHz		
<b>analog inputs</b>	8 x NTC 103AT / NTC NK103 / D.I. / PTC KTY81 / Pt1000 / 0...20 mA / 4...20 mA / 0-10 V / 0-5 V		
<b>connectivity</b>	Ethernet: BACnet IP, Modbus TCP Master/Slave, Webserver, Ftp Client/Server, SNMP CANBus: CANopen 2 x RS485: Modbus RTU (of which 1 x RS485: also BACnet MS/TP) USB (type A); USB (type mini-B); 1 x plug-in EVS		
<b>operating temperature</b>	-20...+60 °C -20...+65 °C (/I models)		

## Electric and mount diagrams

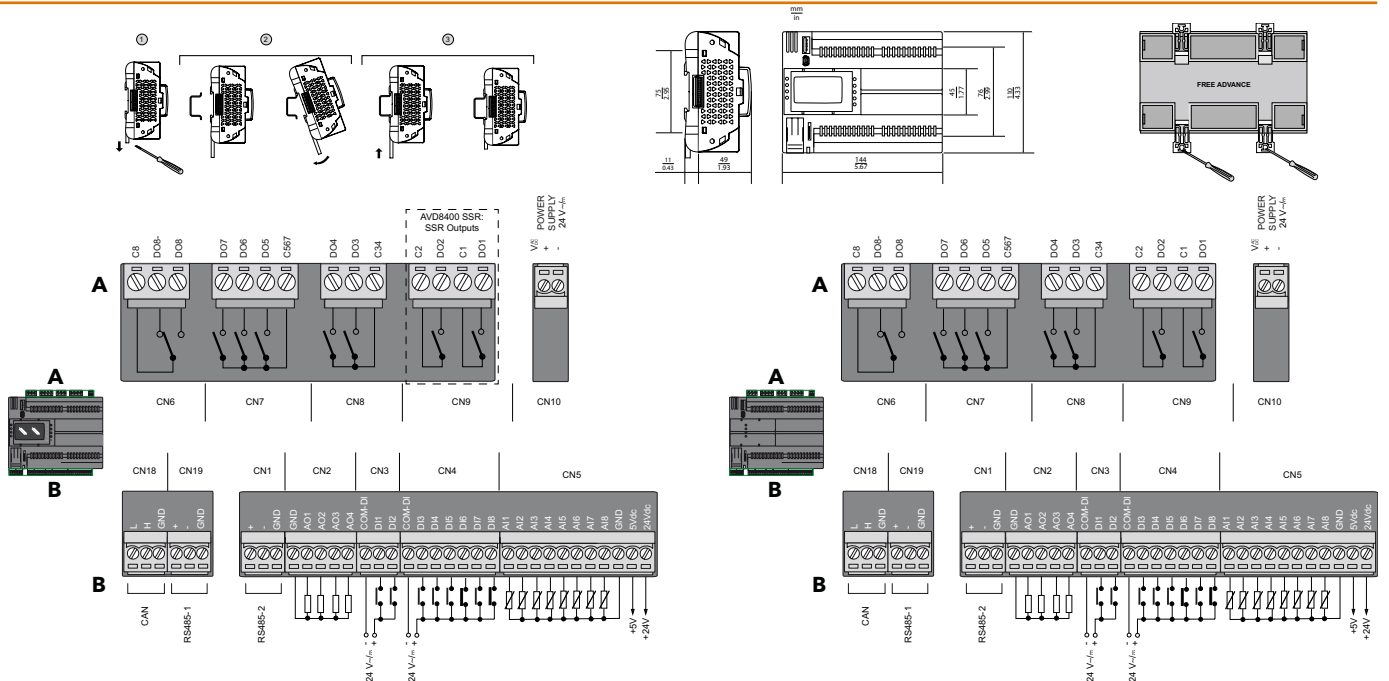

AVD8400 - AVD8400 SSR

AVC/AVD8400



# AVD12600, AVD12600 SSR, AVC12600 /C /L /U (/I)models



AVD12600



AVD12600 SSR



AVC12600

## Technical data

	AVD12600	AVD12600 SSR	AVC12600
size	8 DIN		
display	backlit LCD 128x64 pixel graphic display		
power supply	24 Vac (isolated, /I models only) 20...38 Vdc (isolated, /I models only)		
digital outputs	<b>12:</b> 10 x 3 A, 2 x 1 A 250 Vac	<b>10:</b> 8 x 3 A, 2 x 1 A 250 Vac <b>SSR:</b> 2 x 0.5A 240 Vac	<b>12:</b> 10 x 3 A, 2 x 1 A 250 Vac
analog outputs	<b>6:</b> 4 x 0-10 V, 2 x 0-10 V / 4...20 mA / ON-OFF / PWM / O.C. 24 Vdc 30 mA max		
digital inputs	<b>10 x SELV</b> 2 x pulse/frequency counters up to 2 kHz		
analog inputs	<b>12 x</b> NTC 103 AT / NTC NK103 / D.I. / PTC KTY81 / Pt1000 / 0...20 mA / 4...20 mA / 0-10 V / 0-5 V		
connectivity	Ethernet: Bacnet IP, Modbus TCP Master/Slave, Webserver, Ftp Client/Server, SNMP CANBus: CANopen 2 x RS485: Modbus RTU (of which 1 x RS485: also BACnet MS/TP) USB (type A); USB (type mini-B); 1 x plug-in EVS		
operating temperature	-20...+60 °C -20...+65 °C (/I models)		

## Electric and mount diagrams

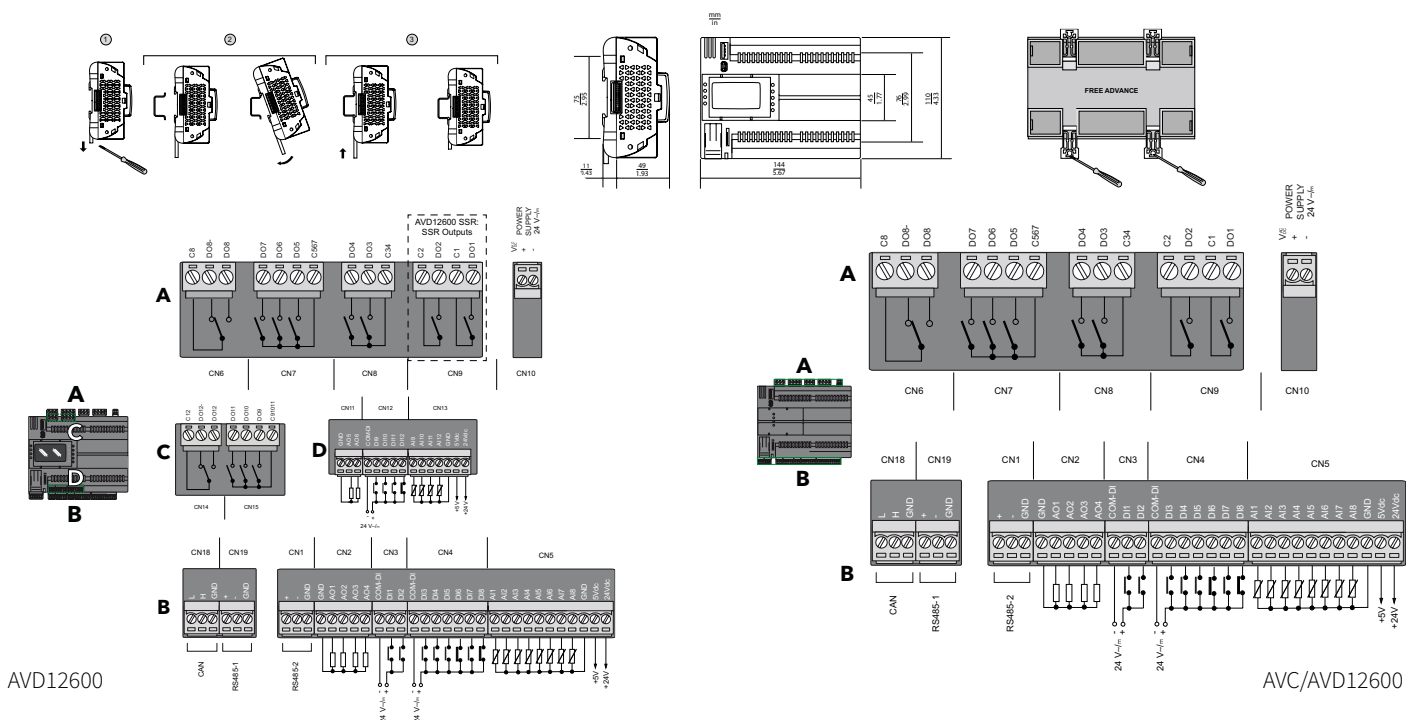

# AVD / AVC 8400, AVD / AVC 12600 /C/I models



AVD8400

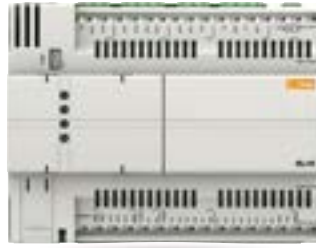

AVC8400

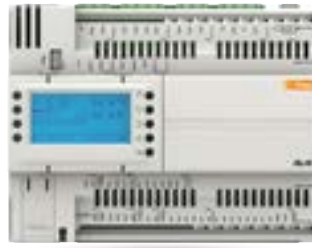

AVD12600



AVC12600

## Technical data

	AVC8400	AVD8400	AVC12600	AVD12600
<b>size</b>	8 DIN			
<b>display</b>	-	backlit LCD 128x64 pixel graphic display	-	backlit LCD 128x64 pixel graphic display
<b>power supply</b>	24 Vac isolated 20...38 Vdc isolated			
<b>digital outputs</b>	8: 7 x 3 A, 1 x 1A 250 Vac		12: 10 x 3 A, 2 x 1 A 250 Vac	
<b>analog outputs</b>	6: 4 x 0-10 V, 2 x 0-10 V / 4...20 mA / ON-OFF / PWM / O.C. 24 Vdc 30 mA max			
<b>digital inputs</b>	6 x SELV 2 x pulse/frequency counters up to 2 kHz			
<b>analog inputs</b>	8 x NTC 103AT / NTC NK103 / D.I. / PTC KTY81 / Pt1000 / 0...20 mA / 4...20 mA / 0-10 V / 0-5 V		12 x NTC 103 AT / NTC NK103 / D.I. / PTC KTY81 / Pt1000 / 0...20 mA / 4...20 mA / 0-10 V / 0-5 V	
<b>connectivity</b>	CANBus: CANopen 2 x RS485: Modbus RTU (of which 1 x RS485: also BACnet MS/TP) USB (type mini-B); 1 x plug-in EVS: Ethernet: BACnet IP, Modbus TCP Master/Slave, Webserver, Ftp Client/Server, SNTp via specific EVS ETH plug-in module			
<b>operating temperature</b>	-20...+65 °C			

## Electric and mount diagrams

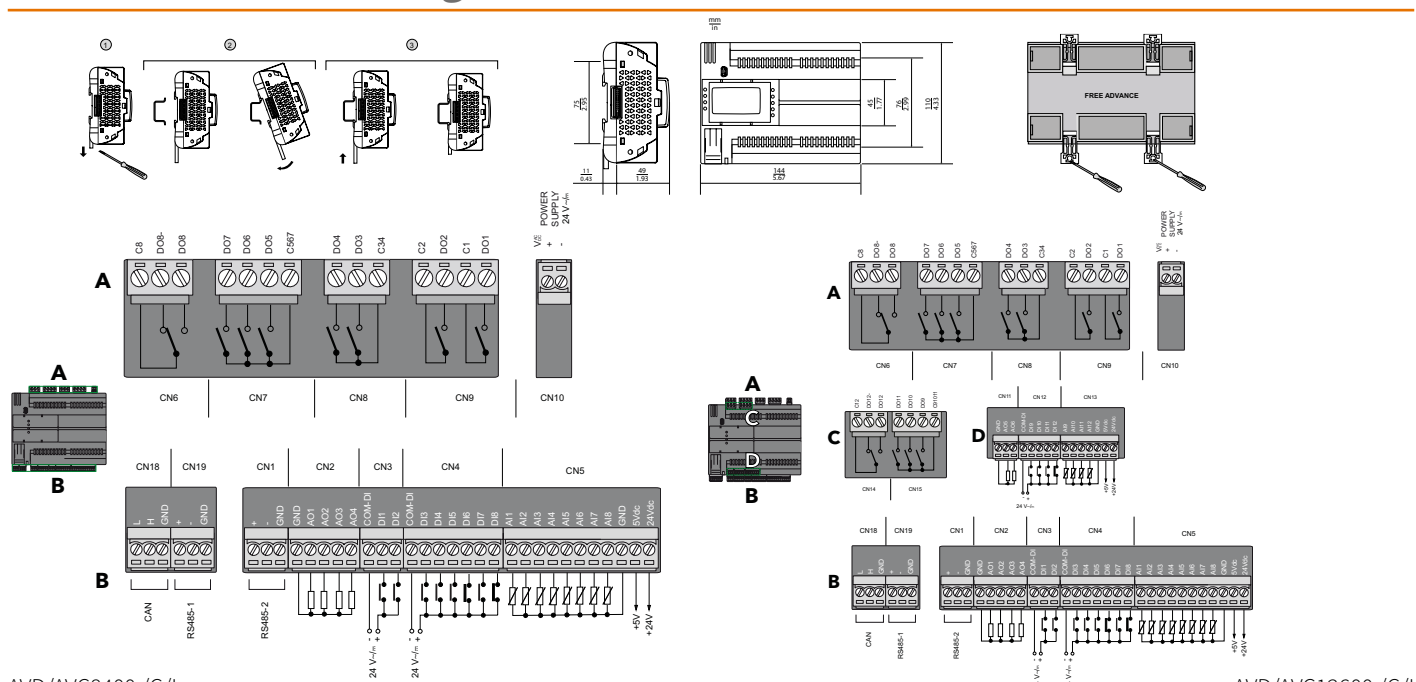

AVD/AVC8400 /C/I

AVD/AVC12600 /C/I

# FREE Evolution models



**FREE Evolution** models (**EVD** with display, **EVC** without display) are available in versions for assembly on 8 DIN rail, with disconnectable screw terminal blocks for quick, easy installation.

Every EVD or EVC is expandable via CANbus (field) up to 7 expansions and 2 terminals (EVK). Up to 10 controllers can also be connected together via CANbus (network).

Up to 127 devices can be controlled with Modbus Master, via RS485.

FREE Evolution

## FREE Evolution with or without display /C indicates units with RTC – Real Time Clock; built-in RS485 and CANbus as standard

Model	Code	Relay outputs at hazardous voltage	SSR outputs	Analog outputs (SELV) <b>A04/A05</b> configurable as Open Collector 12 Vdc 100 mA max each	Digital inputs at safety extra low voltage (SELV)	Digital inputs voltage free	Analog inputs at safety extra low voltage (SELV)
<b>EVD7500/C/U</b>	EVD7500060B00	7	-	5	8	1*	6
<b>EVD75SS/C/U</b>	EVD75SS060B00	5	2	5	8	1*	6
<b>EVC7500/C/U</b>	EVC7500060B00	7	-	5	8	1*	6

\*Fast counter 1 kHz

\*\* Also compatible with EVE4200 and EVE10200

## Expansions RS485 (EVE7500 only) and built-in CANbus as standard

Model	Code	Relay outputs at hazardous voltage	SSR outputs	Analog outputs (SELV) <b>A04/A05</b> configurable as Open Collector 12 Vdc 100 mA max each	Digital inputs at safety extra low voltage (SELV)	Digital inputs voltage free	Analog inputs at safety extra low voltage (SELV)
<b>EVE7500</b>	EVE7500000B00	7	-	5	8	1*	6
<b>EVE4200</b>	EVE4200000500	4	-	2	4	-	4

\*Fast counter 1 kHz

### Minimum developer kit - FREE Evolution

- FREE Studio Plus installation setup
- 1 FREE Evolution EVD7500/C/U
- USB cable
- FREE Evolution power supply transformer

### USB Host USB → ← FREE



Data download direction	→	←
Parameter map	✓	✓
IEC application	✓	✓
HMI application	✓	✓
Data files	✓	✓
BIOS	✓	-

### USB Device PC → ← FREE



Data download direction	→	←
Parameter map	-	-
IEC application	✓	✓
HMI application	✓	✓
Data files	✓	✓
BIOS	✓	-

### USB-RS485 / Ethernet + Plugin PC → ← FREE



Data download direction	→	←
Parameter map	✓	✓
IEC application	✓	-
HMI application	✓	-
Data files	✓	✓
BIOS	✓	-

# EVD7500, EVD75SS, EVC7500



EVD7500



EVD75SS



EVC7500

## Technical data

	EVD7500	EVD75SS	EVC7500
<b>size</b>	8 DIN		
<b>display</b>	backlit LCD 128x64 pixel graphic display		
<b>power supply</b>	24 Vac/dc - 48 Vdc isolated		
<b>digital outputs</b>	7: 2 x 8 A, 5 x 5 A 250 Vac	5: 2 x 8 A, 3 x 5 A 250 Vac SSR: 2 x 1 A 250 Vac	7: 2 x 8 A, 5 x 5 A 250 Vac
<b>analog outputs</b>	5 x 0-10 V / 4...20 mA / (switch 0..20 mA) AO4/AO5 configurable as O.C. 12 Vdc 100 mA max each		
<b>digital inputs</b>	8 x SELV 1 x voltage free fast counter 1 kHz		
<b>analog inputs</b>	2 x NTC 103 AT / NTC NK103 / D.I. 4 x NTC 103 AT / NTC NK103 / D.I. / Pt1000 / 4...20 mA / 0-10 V / 0-5 V		
<b>connectivity</b>	USB; 1 x Plug-in EVS CANBus isolated: CANopen RS485 isolated: Modbus RTU		
<b>operating temperature</b>	-10...+55 °C		

## Electric and mount diagrams

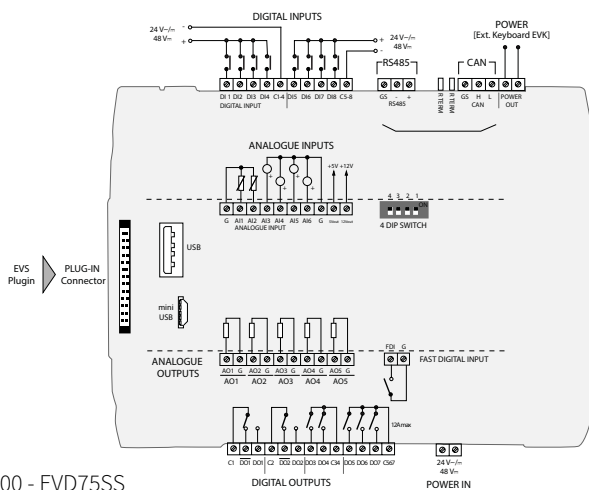
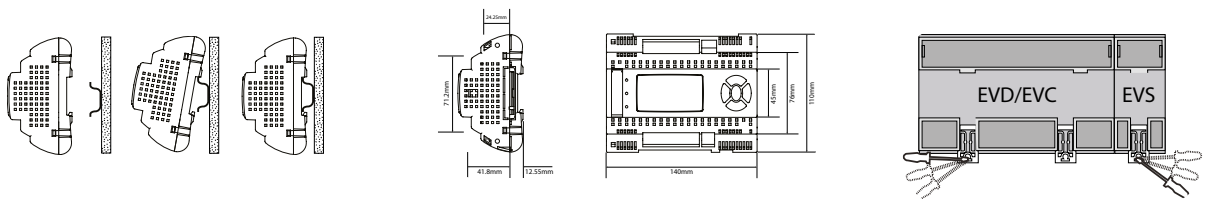

EVD7500 - EVD75SS

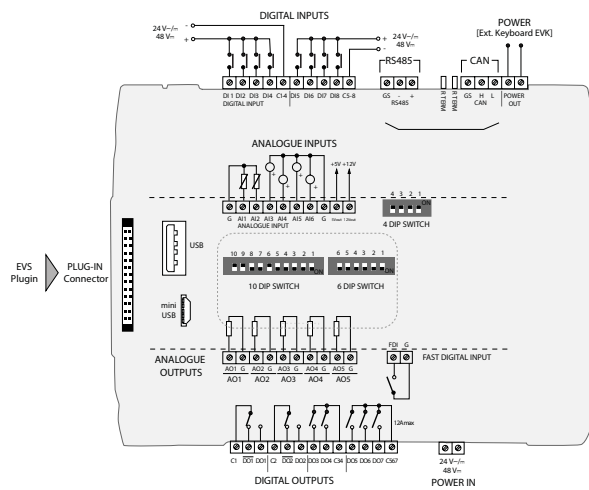

EVC7500

# EVK1000 terminal



EVK1000

## Technical data

EVK1000	
size	160x96x10 mm
mount	panel (for wall mount see Accessories page)
display	Backlit LCD
power supply	24 Vac/dc - 48 Vdc isolated
connectivity	CANBus isolated: CANopen
operating temperature	-5...+55 °C
code	EVK1000000B00

## Electric, mount and dimensional diagrams

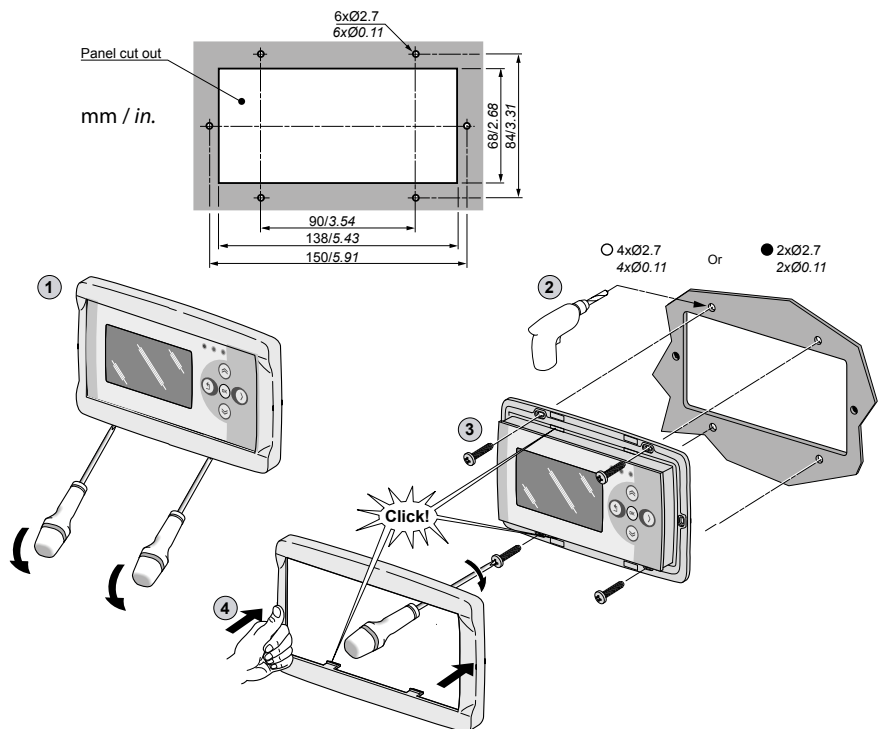
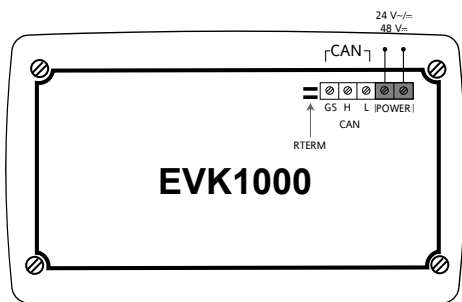

# Expansions EVE7500, EVE4200



EVE7500



EVE4200

## Technical data

	EVE7500	EVE4200
<b>size</b>	8 DIN	
<b>mount</b>	on DIN rail	
<b>display</b>	-	
<b>power supply</b>	24 Vac/dc - 48 Vdc isolated	24 Vac/dc
<b>digital outputs</b>	2 x 8 A 250 Vac 5 x 5 A 250 Vac	1: 1 x 5 A 250 Vac 3: 3 x 3 A 250 Vac
<b>analog outputs</b>	5 x 0-10 V / 4...20 mA / switch 0..20 mA	2 x 0-10 V
<b>digital inputs</b>	8 x SELV	4 x SELV
<b>analog inputs</b>	1 x voltage free fast counter 1 kHz 2 x NTC 103 AT / NTC NK103 / D.I. 4 x NTC 103 AT / NTC NK103 / D.I. / Pt1000 / 4...20 mA / 0-10 V / 0-5 V	4 x NTC 103AT / NTC NK103 / D.I. / Pt1000 / PTC / 4...20 mA / 0-10 V / 0-5 V -
<b>connectivity</b>	CANBus isolated: CANopen RS485 isolated: Modbus RTU 1 x EVS Plugin (only EVS RS485, EVS CAN)	CANBus: CANopen - -
<b>operating temperature</b>	-10...+55 °C	-5...+55 °C

## Electric, mount and dimensional diagrams

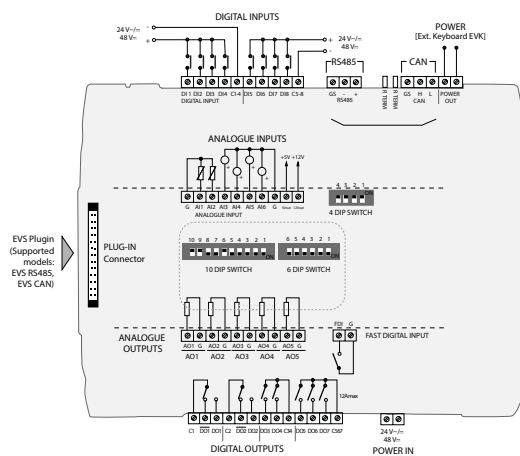
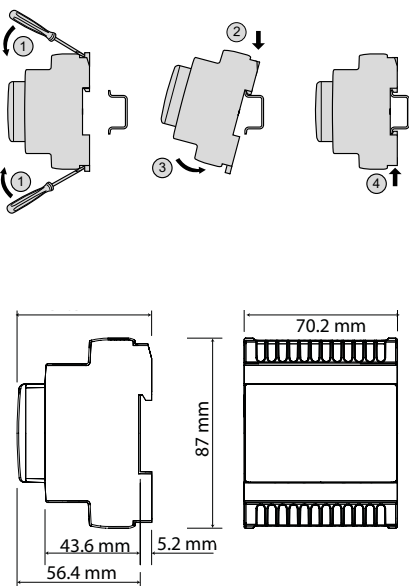

EVE7500

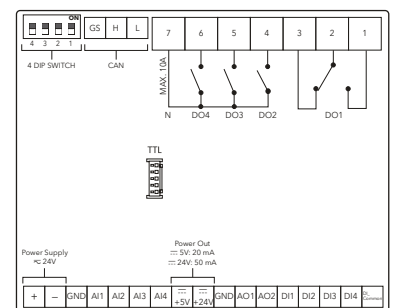

EVE4200

# Expansions EVE6000, EVE10200



EVE6000

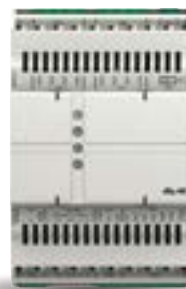

EVE10200

## Technical data

	EVE6000	EVE10200
<b>size</b>		4 DIN
<b>mount</b>		on DIN rail
<b>power supply</b>		24 Vac 20...38 Vdc
<b>digital outputs</b>	6: 6 x 3 A 250 Vac	10: 10 x 3 A 250 Vac
<b>analog outputs</b>	-	2: 2 x 0-10 V, 2 x 0-10 V / 4...20 mA / ON-OFF / PWM / O.C. 24 Vdc 30 mA max
<b>digital inputs</b>	-	4 x SELV
<b>analog inputs</b>	2 x pulse/frequency counters up to 2 kHz	2 x pulse/frequency counters up to 2 kHz
<b>connectivity</b>		CANBus: CANopen
<b>operating temperature</b>		-20...+65 °C

## Electric, mount and dimensional diagrams

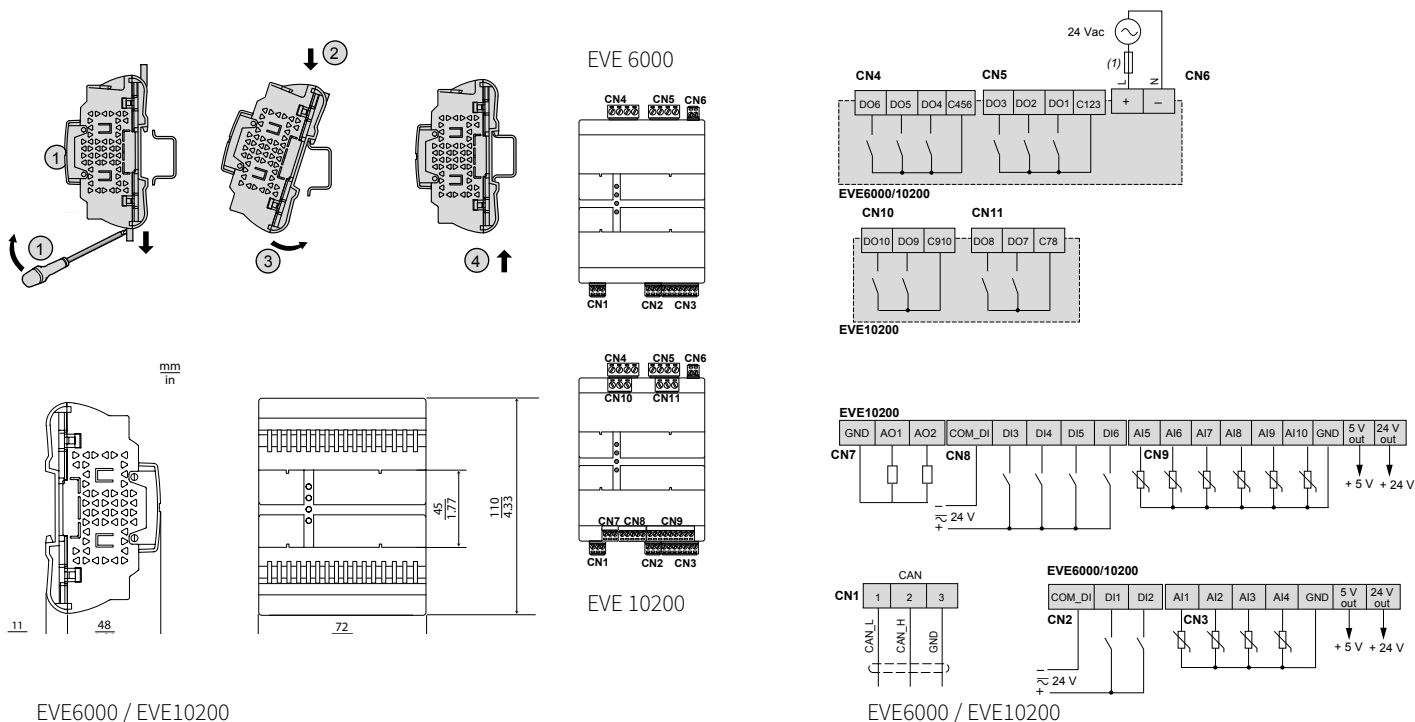

# Plugin EVS



EVS RS485



EVS ETH



EVS LON



EVS CAN



EVS RS232

## Technical data

### EVS

<b>size</b>	2 DIN
<b>mount</b>	on DIN rail
<b>power supply</b>	from base EVD/EVC/AVD

### Connectivity

Model	Code	Hazardous voltage output	Connectivity protocol	Compatibility
<b>EVS RS232</b>	EVS10R2000000	1 x SPDT 5A 250 Vac	Modbus ASCII	FREE Advance - FREE Evolution
<b>EVS RS485</b>	EVS00R4000000	-	Modbus RTU	FREE Advance - FREE Evolution
<b>EVS CAN</b>	EVS00CA000000	-	CANopen	FREE Advance - FREE Evolution
<b>EVS Bacnet</b>	EVS00BM000000	-	Modbus RTU - BACnet MSTP	FREE Advance - FREE Evolution
<b>EVS LONWORKS</b>	EVS0LON000000	-	LON	FREE Advance - FREE Evolution
<b>EVS ETH</b>	EVS00ET000000	-	Modbus TCP - BACnet IP - WebServer	FREE Advance /C /I - FREE Evolution
<b>EVS Profibus</b>	EVS00PB000000	-	Profibus DP Slave-V0	FREE Evolution
<b>EVS ETH/RS485</b>	EVS00EB000000	-	Modbus RTU - BACnet MSTP - Modbus TCP - BACnet IP - Webserver	FREE Evolution

## Electric, mount and dimensional diagrams

### EVS ETHERNET

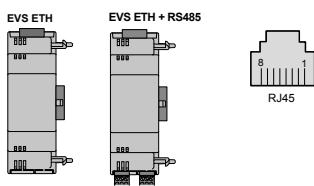

### EVS LON

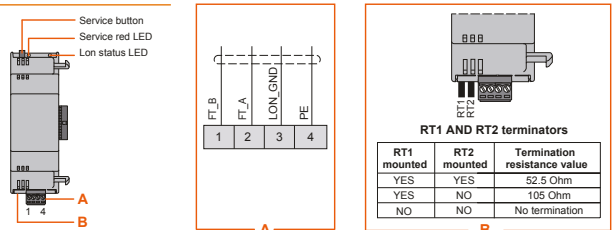

### EVS CAN

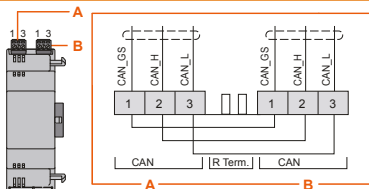

### EVS RS232/R

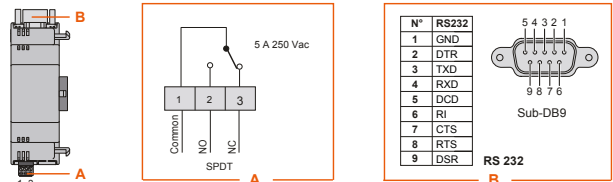

### EVS RS485 BACnet MS/TP

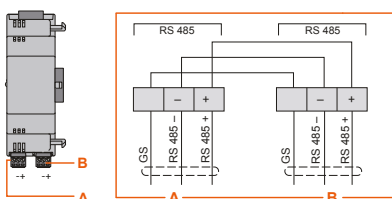

### EVS RS485

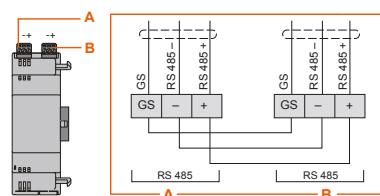



# Accessories

In association with FREE Smart, FREE Panel, FREE Evolution and FREE Advance, Eliwell supplies a vast range of accessories, from a protected transformer to IP68 temperature probes, ratiometric pressure transducers and pressure switches.

Single-phase (with currents from 2 to 9A) and three-phase fan modules are available.

No additional serial interfaces are required for connection of ratiometric pressure probes, external modules (such as fan modules) or terminals.

## FREE Smart accessories

### Converters, interfaces, programming keys

Code	Description	Details
<b>SARORA00X701</b>	USB/485 MINI KIT converter	-
<b>DMI1003002000</b>	DMI100-3 Manufacturer interface module	For FREE Smart only
<b>MFK100T000000</b>	MFK: programming key for parameter, application upload/download	For FREE Smart only



### Wiring

Code	Description	Details
<b>COLV0000E0100</b>	I/O connection wiring - safety extra low voltage (SELV) - 1 m cable	FREE Smart 12...24V only
<b>COLV000035100</b>	RS485 Wiring	FREE Smart 12...24V only
<b>COLV000042100</b>	Wiring AO3-4-5 -1 m cable	FREE Smart 12...24V only



### Connectivity

Code	Description	Details
<b>BA10000R3700</b>	BusAdapter 150 TTL-RS485	For FREE Smart only



### Humidity module

Code	Description	Details
<b>KP100000</b>	Humidity module %RH	For SKW terminal



### Demo Case

Code	Description	Details
<b>VAL00031K</b>	Demo Case for FREE Smart	-



### Temperature probes\*

Code	Description	Details
<b>SN8DED11502C0</b>	NTC 103AT 5X20 1.5 mt TPE IP68	-
<b>SN8DAE11502C0</b>	NTC 103AT 6X20 1.5 mt TPE IP68	-
<b>SN9DAE11502C6</b>	Pt1000 6X20 1.5 mt IP68	FREE Smart 4500
<b>SN9DED11502C6</b>	Pt1000 5X20 1.5 mt IP68	



### Transformers

Code	Description	Details
<b>TF411205</b>	Transformer 230 Vac/12 V 6 VA (protected)	For FREE Smart only
<b>TF411210</b>	Transformer 230 Vac/12 V 11 VA (protected)	For FREE Smart only
<b>TF111211</b>	Transformer 220 Vac/24 V-24 V 16 VA	For FREE Smart only



KEY: SELV = Safety Extra Low Voltage

\*different cable lengths available on request



## FREE Advance, FREE Evolution and FREE Panel accessories

### Converters, interfaces, programming keys



Code	Description	Details
SAR0RA00X701	USB/485 MINI KIT converter	-
EVA00USCA0000	USB/CAN converter	-

### Base plates

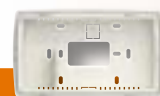

Code	Description	Details
EVA00WMRC0000	Kit (4 Pcs) White base plate for wall mount	For EVP/EVK
EVA00WMRC0001	Kit (4 Pcs) Black base plate for wall mount	For EVP/EVK
AVA00WMRC0000	White base plate for wall mount	For AVP1000
AVA00WMRC0001	Grey base plate for wall mount	For AVP1000

### Demo Case



Code	Description	Details
VAL00033K	Demo Case for FREE Evolution	-
VAL00034	Demo Case for FREE Advance	-

### Temperature probes\*



Code	Description	Details
SN8DED11502C0	NTC 103 AT 5X20 1.5 m TP IP68	-
SN8DAE11502C0	NTC 103 AT 6X20 1.5 m TP IP68	-
SN9DAE11502C6	Pt1000 6X20 1.5 m IP68	FREE Evolution / FREE Advance
SN9DED11502C6	Pt1000 5X20 1.5 m IP68	

### Transformers



Code	Description	Details
TF111202	Transformer 230V~/24 V 25 VA	For FREE Evolution only
TF111205	Transformer 230V~/24 V 35 VA DIN rail mount	FREE Evolution / FREE Advance

## FREE range accessories

### Pressure transducers



Code	Description	Details
TD220050	EWPA050 4...20 mA / 0...667 psi / 0..50 bar IP54** 2 m cable	1/4 SAE MALE
TD220007	EWPA007 4...20 mA / -7...101.5 psi / -0.5..7 bar IP54** 2 m cable	1/4 SAE MALE
TD320050	EWPA050 4...20 mA / 0...667 psi / 0..50 bar IP54** 2 m cable	1/4 SAE FEMALE
TD320007	EWPA007 4...20 mA / -7...101.5 psi / -0.5..7 bar IP54** 2 m cable	1/4 SAE FEMALE

### Ratiometric transducers



Code	Description	Details
TD420010	EWPA 010 R 0...145 psi / 0...10 bar IP67 2 m cable (packard connector)	Female connection
TD420030	EWPA 030 R 0...508 psi / 0...30 bar IP67 2 m cable (packard connector)	Female connection
TD420050	EWPA 050 R 0...667 psi / 0...50 bar IP67 2 m cable (packard connector)	Female connection

### Expansions, fan modules



Code	Description	Details
MW320100	EXP11 250 V 10 A expansion with DIN rail mount base	Open Collector Output
MW991012	CFS05 TANDEM TRIAC 5+5 A 250 V	-
<b>CFS Modules</b>	CFS - Single-phase speed regulators for currents from 2 A to 9 A	Various articles available

KEY: SELV = Safety Extra Low Voltage

\*different cable lengths available on request \*\*optional IP67 version with packard connector



```
<div class="pinSocialMeta">
```

```
<a class="socialItem"
```

```
href="/pin/297026537901201080/repins/" data-element-type="174">
```

```
<em class="repinIconSmall"></em>
```

```
<em class="socialMetaCount repinCountSmall">
```

```
<a class="socialItem likes" href="/pin/297026537901201080/likes/" da
```

```
<em class="likeIconSmall"></em>
```

```
</div>
```



```
admin
*****
submit reset
```

```
type="text"
```

```
<span class="accessibilityText">Enter your </span></button>
```

```
<button class="Button DropdownButton Module UserEducationDropdownBu
```

```
moreFooter footerIcon emptyTutorialButton" data-element-type="245" id="Use
```

```
dropdown-203" type="button">
```

Life Is On



**ITALY - HEADQUARTERS**

**Eliwell Controls Srl**

Via dell' Industria, 15 Z. I. Paludi

32016 Alpago (BL) Italy

T +39 0437 986 111

**Sales**

T +39 0437 986 100 (Italy)

T +39 0437 986 200 (other countries)

E: saleseliwell@schneider-electric.com

**Technical support**

T +39 0437 986 250

E: eliwell.freeway@schneider-electric.com

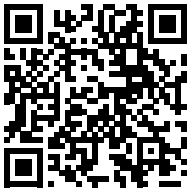

**Contact us**



**www.eliwell.com**

Follow us on  

CT123390 • rel. 10/18  
© 2018 Eliwell - All rights reserved

Eliwell has been delivering control systems and services for commercial and industrial refrigeration and air-conditioning units for more than 35 years, with ground-breaking products packed with state-of-the-art technology. Eliwell is a company of the Schneider Electric Group. Subscribe to our newsletter on the [www.eliwell.com](http://www.eliwell.com) website.