

Life Is On

eliwellTM
by Schneider Electric

free Way

Programmable platform



General description

Eliwell's programmable platform

FREE Way: the new Eliwell approach to programmability, giving customers the tools to find their own faster and more effective solutions.

FREE Way is the new programmable platform from Eliwell, consisting of the **FREE Studio** software Suite, **FREE Smart**, **FREE Panel** and **FREE Evolution**, the new programmable controller range available in various sizes to choose from.

FREE Studio software suite, simple and flexible, is compatible with the 5 standard programming languages (**IEC 61131-3**), and is structured to manage a whole range of controllers of different sizes and with varying levels of complexity, in order to satisfy all the customer's system customisation requirements.



FREE Smart

Specifications

FREE Studio

- Unique software suite for fast and easy programming
- Advanced debugging and simulation options and complete, efficient online Help
- Protection of applications and different use levels
- Application revision log
- Customisable interface

Free Smart

- User interface with configurable keys.
- Available in three formats, in versions 100...240V~ and 12...24V~/ 24VDC:
 - **FREE Smart SMP** Panel mounting (32x74mm) with LED display
 - **FREE Smart SMD** 4 DIN with LED display, **FREE Smart SMC** 4 DIN with no display
- Can be connected to RS-485, Modbus RTU, or standard Eliwell peripherals and user interfaces.

FREE Panel

- **FREE Panel EVP** system controller, with gateway functions and backlit LCD graphic display
- High connectivity: can be integrated in industrial systems and BMS
- Connects to standard Eliwell and third-party peripheral devices
- Can be panel or wall-mounted

FREE Advance

- Fully customisable graphic user interface.
- Available in formats: 8 Din **FREE Advance AVD** with backlit LCD graphic display, **FREE Advance AVC** without display
- High connectivity on board as standard for integration with industrial systems and BMS without optional modes
- Connects to standard Eliwell and third party peripheral devices (including FREE Smart)

FREE Evolution

- Fully customisable graphic user interface.
- Available in formats: 8 Din **FREE Evolution EVD** with backlit LCD graphic display, **FREE Evolution EVC** without display
- High connectivity: integrates into industrial systems and BMS using dedicated plug-in modules.
- Connects to standard Eliwell and third party peripheral devices (including FREE Smart)

Certification  based on the model indicated in the UL reference file no. E233482

Speed

One of the main goals of the free programmable platform is to give our customers the tools to find faster, more effective solutions for their customers. Many features of FREE make it possible to effectively reduce the time between defining a new application and putting it into production.

Compact dimensions

The FREE programmable platform enables customers to keep costs at a competitive level. The FREE controllers are made with particular emphasis placed on technological solutions and physical size, for significant results in terms of simplicity, modularity and compactness. The integrated solutions and small size of FREE controllers provide real, immediate economic advantages for customers.

Efficiency

The FREE programmable platform, complete and scalable across various levels of complexity, offers customers great freedom in choosing the solution they feel is best suited to their own requirements. This makes it easier to find solutions which take account of costs and/or the reduction of product codes, including solutions which are more open to future development or future system requirements, with particular reference to connectivity.

Reliability

The high quality of the new FREE Way programmable platform allows customers to reduce any costs linked to a lack of quality, during both the production process and on-site installation procedures. The **FREE Smart, FREE Panel, FREE Advance, and FREE Evolution controllers** and **FREE Studio development** environment were designed using innovative but carefully reconstructed criteria, adopting advanced and stable technological solutions as well as certified, monitored production processes. Eliwell has always been a byword for reliability.



FREE Panel



FREE Advance



FREE Evolution



Remote display

The FREE Way targets

Manufacturers of:

- A.T.U. (Air Treatment Units)
- Chillers
- Heat Pumps
- Rooftops
- Precision conditioning systems
- Compressor Racks

Installers/integrators of:

- All air systems
- Hydronic systems
- Combo systems (air/water)
- Commercial automation

FREE Studio

FREE Studio software suite is compatible with all 5 standard programming languages (**IEC61131-3**).

Each project may be composed of several programs; the developer can use one or more languages in the same project.

Each new program offers the choice of 5 programming languages, 2 text-based and 3 graphics-based:

- **ST, Structured Text**
- **FBD, Functional Block Diagram**
- **LD, Ladder**
- **IL, Instruction List**
- **SFC, Sequential Function Chart**

IEC61131-3 development software

Main Functions

Display variables with application running

Debugging of variables by displaying their status in numerical format when the application is running and connected to FREE Smart, FREE Panel and FREE Evolution

Function libraries

Management of default function libraries and/or those created by the developer. Any additional boards are managed by that developer.

Display variables graph

Debugging of variables by displaying their status in graphics-based format when the application is running and connected to FREE Smart, FREE Panel and FREE Evolution

Reading / writing of variables.

The operating environment makes the following possible:

- Creation of special menus to be shown on the controller display.
- reading and writing BIOS parameters (parameters + I/O values)
- reading and writing parameters and variables defined by the developer in Applications linked to the menu.

Online Help for programmers at all stages of the programme development process, accessible from the work screen by simply pressing F1.

The entire help is also available in a printable pdf.

Baselines and Libraries ready for use for downloading from the web

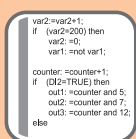

ST

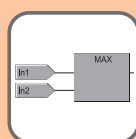

FBD

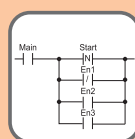

LD

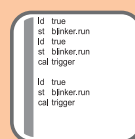

IL

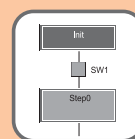

SFC

Components

FREE Studio allows the developer to program in different work environments, having releases at his disposal that are always updated with new functions and optimizations, available in the dedicated area of the Eliwell site.



Baselines

Applications ready for use, in compliance with the rules of architecture, easily modified for all requirements.

The applications and object **libraries** will help to speed up your work even more, making FREE Studio easier to use.

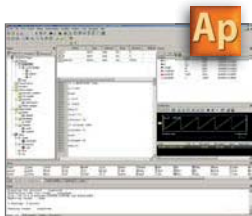

Application

Component for software developers to allow them to develop and modify applications in the 5 standard programming languages.

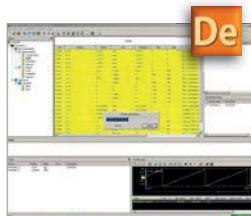

Device

Component dedicated to less skilled users for the management of parameters, application downloads, field tests, etc.



Connection

Configuration component for both field and open networks, for integration with other systems.



User Interface

Component for developing and customising the graphic user interface.



Simulation

Component for simulating the application on a PC.

Installation and system requirements

Operating Systems

- Windows 10
- Windows 8, 8.1
- Windows 7 Home / Professional / Ultimate

Installation setup, software updates, reference libraries and documentation are also available from the Restricted Area of the website eliwell.com once you have registered.

FREE Smart Models

The models are available as a DIN rail-mounted version (SMD with display, SMC with no display) and in the compact 32x74 Eliwell (SMP) size for panel-mounting.

Various expansion modules (SME) and terminals (SKP, SKW) are also supplied for use in conjunction with the corresponding models in the FREE Smart range.

All inputs and outputs are independent and configurable to maximise the units' adaptability to any system



FREE Smart 12...24V~ / 24V... /C indicates the presence of Real-Time Clock (RTC)

Model	Code	Digital outputs dangerous voltage	TRIAC outputs dangerous voltage	O.C. outputs: PWM/PPM safety extra low voltage SELV	Analogue outputs 0..10V safety extra low voltage SELV	Digital outputs no voltage	Analogue inputs safety extra low voltage SELV	O.C. outputs	RS 485 on board
SMP5500/C/S	SMP5500050450	5	-	2	3	6	5	1	yes
SMP5500/C	SMP5500010450	5	-	2	3	6	5	1	-
SMD5500/C/S	SMD5500050450	5	-	2	3	6	5	1	yes
SMD5500/C	SMD5500010450	5	-	2	3	6	5	1	-
SMD3600/C/S	SMD3600050450	3	2	1	3	6	5	1	yes
SMC5500/C/S	SMC5500050450	5	-	2	3	6	5	1	yes
SMC5500/C	SMC5500010450	5	-	2	3	6	5	1	-

Expansion modules

SME3200	SME3200000400	3	-	2	-	6	3	1	-
SME5500	SME5500000450	5	-	2	3	6	5	1	-

FREE Smart 100...240V~ /C indicates the presence of Real-Time Clock (RTC); /S indicates integrated on-board RS485 serial port

Model	Code	Digital outputs dangerous voltage	O.C. outputs: PWM / DI safety extra low voltage SELV	Outputs 0..10V safety extra low voltage SELV	Outputs 4...20mA 0...20mA	Analogue inputs safety extra low voltage SELV
SMD4500/C/S	SMD4500050H00	4	2	2	1	5
SMD4500/C	SMD4500010H00	4	2	2	1	5
SMC4500/C/S	SMC4500050H00	4	2	2	1	5

Expansion module

SME4500	SME4500000H00	4	2	2	1	5
----------------	---------------	---	---	---	---	---

Terminals with power supply from the base

Model	Code	Installation	Dimensions	Display	Analogue inputs safety extra low voltage SELV
SKP10	SKP100G000000	Panel	74x32x30 mm	LED / 4 digit	-
SKW22	SKW220G000000	Wall	137x96.5x31.3 mm	LCD	1 integrated NTC 1 NTC/DI/4...20mA input
SKW22L	SKW22LG000000	Wall	137x96.5x31.3 mm	Backlit LCD	1 integrated NTC 1 NTC/DI/4...20mA input
SKP22	SKP220G000000	Panel; Wall: see page 17 (accessories)	160x96x10mm	LCD	1 NTC input 1 NTC/DI/4...20mA input

KEY: SELV = Safety Extra Low Voltage; PPM = Pulse Position Modulation; PWM = Pulse Width Modulation; O.C. = Open Collector

Resources available - FREE Smart (model /C/S, msk 412)

The IEC programmer includes the following resources:

CPU	14.7 MHz
Available memory for Application	190 KByte
RAM memory - automatic mapping	2300 Byte
RAM memory - Modbus mapping	1024 Byte
EEPROM variables	1024 Byte

Minimum kit for the developer - FREE Smart

- FREE Studio installation setup
 - 1 FREE Smart SMxxxx*
 - 1 DMI 100-3 Manufacturer + yellow TTL cable
 - 1 optional MFK + blue TTL cable
 - FREE Smart* power cables and transformer
- * alternatively, request the Demo Case

FREE Smart Connectivity



FREE Smart controllers are equipped with a serial port for easy integration with the supervision systems of the plant in which they are installed.

ModBus standard protocol makes it possible to access all the controller resources, thereby guaranteeing complete system control.

All models have TTL supplied as standard; /S models have an integrated RS485 serial port.

A special firmware version also offers Modbus MASTER functions.

FREE Smart maximum configuration

- Max 1 FREE Smart model
- Max 1 SME expansion module via LAN serial port
- Max 1 SKP10 terminal with controller ECHO function
- Max 1 SKW22(L) or SKP22 terminal with dedicated menu, with the possibility of monitoring the environment temperature and humidity
- Maximum LAN distance: 100 m

FREE Smart Update Function

The Multi Function Key (MFK 100) can be used to upload and download the parameters map for rapid configuration, to upload IEC and BIOS applications.

Multi Function Key / DMI
PC → ← FREE

use **blue TTL cable** for DMI - MFK connection

Direction of download	→	←
Parameters map	-	-
IEC application	✓	-
BIOS	✓	-

Multi Function Key
MFK → ← FREE

use **yellow TTL cable** for MFK - target connection

Direction of download	→	←
Parameters map	✓	✓
IEC application	✓	-
BIOS	✓	-

Network
PC → ← FREE

use **yellow TTL cable** for DMI - target connection

Direction of download	→	←
Parameters map	✓	✓
IEC application	✓	-
BIOS	✓	-

Example of connection in Modbus Slave or Master mode

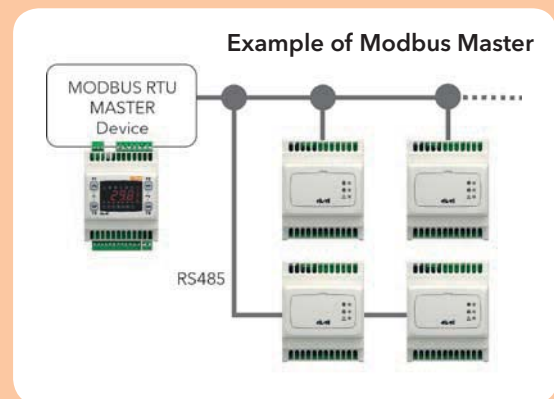
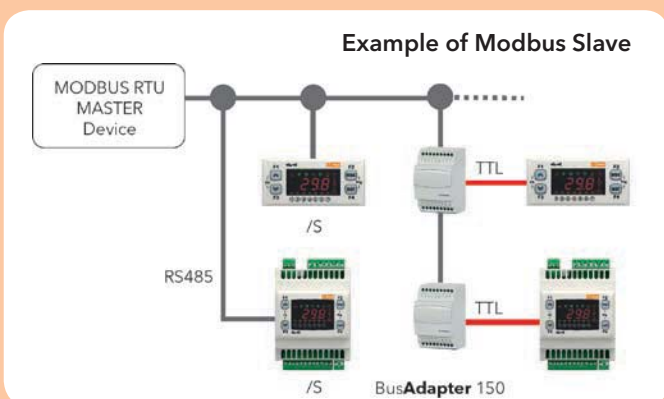

For models without RS485 use exclusively BusAdapter 150

SMP, SMD, SMC5500



SMP5500



SMD5500



SMC5500

Technical Data

	SMP5500	SMD5500	SMC5500
format	32x74x80mm (Lxhxd)	4DIN	4DIN
display	LED 4 digits - 7 segments	LED 4 digits - 7 segments	-
power supply	12...24V~ / 24V= not insulated	12...24V~ / 24V= not insulated	12...24V~ / 24V= not insulated
relay digital outputs	5 x 2A 250V~	5 x 2A 250V~	5 x 2A 250V~
analogue outputs	2 x O.C. PPM/PWM 3 x 0...10V	2 x O.C. PPM/PWM 3 x 0...10V	2 x O.C. PPM/PWM 3 x 0...10V
O.C. digital outputs	1 x Open Collector	1 x Open Collector	1 x Open Collector
digital inputs	6 voltage free	6 voltage free	6 voltage free
analogue inputs	3 x NTC/ D.I. 2 x NTC/ D.I. / 0...20mA / 4...20mA / 0-10V / 0-5V / 0-1V	3 x NTC/ D.I. 2 x NTC/ D.I. / 0...20mA / 4...20mA / 0-10V / 0-5V / 0-1V	3 x NTC/ D.I. 2 x NTC/ D.I. / 0...20mA / 4...20mA / 0-10V / 0-5V / 0-1V
connectivity	TTL RS485 (only /S models) LAN for connection to SKP/SKW terminal or to SME expansion module	TTL RS485 LAN for connection to SKP/SKW terminal or to SME expansion module	TTL RS485 (only /S models) LAN for connection to SKP/SKW terminal or to SME expansion module
operating temperature	-20...+55°C	-20...+55°C	-20...+55°C

Wiring, assembly and dimensional diagrams

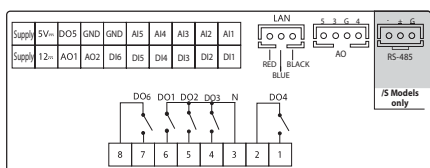
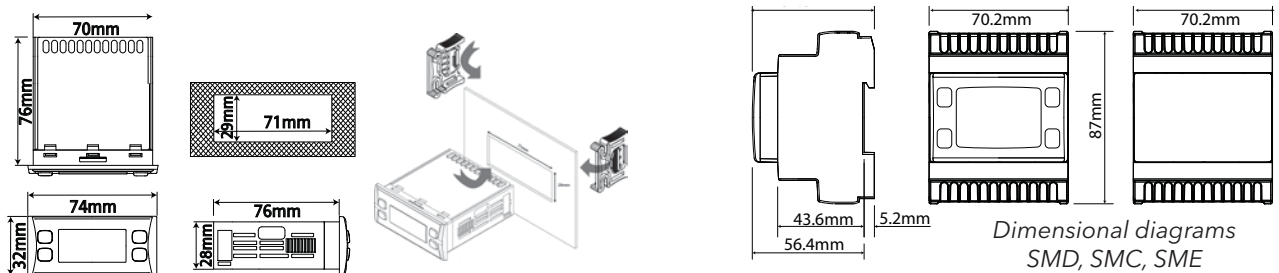

SMP5500/C - SMP5500/C/S

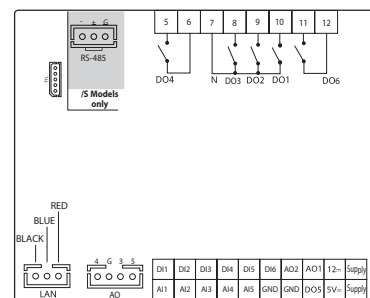

SMD5500/C/S - SMC 5500/C - SMC5500/C/S

SMD3600, Expansion modules SME



SMD3600



SME3200



SME5500

Technical Data

	SMD3600	SME3200	SME5500
format	4DIN	4DIN	4DIN
display	LED 4 digits - 7 segments	-	-
power supply	12...24V~ not insulated	12...24V~ / 24V= not insulated	12...24V~ / 24V= not insulated
relay digital outputs	3 x 2A 250V~	3 x 2A 250V~	5 x 2A 250V~
analogue outputs	2 x TRIAC 3A 250V~ 1 x Open Collector PPM/PWM 3 x 0...10V	- 2 x Open Collector PPM/PWM -	- 2 x Open Collector PPM/PWM 3 x 0...10V
O.C. digital outputs	2 x Open Collector	1 x Open Collector	1 x Open Collector
digital inputs	6 voltage free	6 voltage free	6 voltage free
analogue inputs	3 x NTC/ D.I. 2 x NTC/ D.I. / 0...20mA / 4...20mA / 0-10V / 0-5V / 0-1V	3 x NTC/ D.I. -	3 x NTC/ D.I. 2 x NTC/ D.I. / 0...20mA / 4...20mA / 0-10V / 0-5V / 0-1V
connectivity	TTL	TTL	TTL
	RS485	-	-
	LAN for connection to SKP/SKW terminal or to SME expansion module	LAN for connection to FREE Smart	LAN for connection to FREE Smart
operating temperature	-20...+55°C	-20...+55°C	-20...+55°C

Wiring diagrams

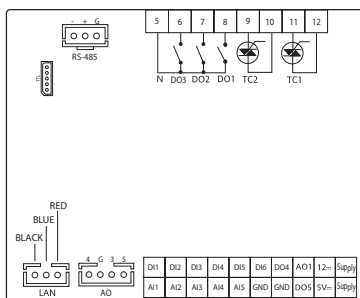

SMD3600/C/S

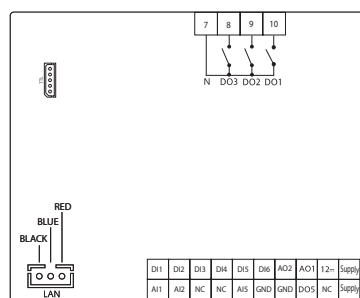

SME3200

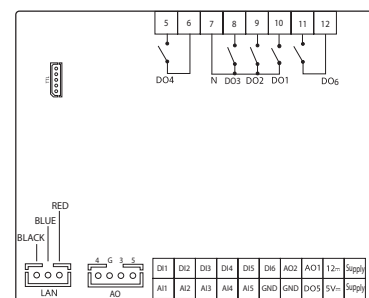

SME5500

SMD, SMC4500, Expansion module SME4500



SMD4500



SMC4500



SME4500

Technical Data

	SMD4500	SMC4500	SME4500
format	4DIN	4DIN	4DIN
display	LED 4 digits - 7 segments	-	-
power supply	100...240V~	100...240V~	100...240V~
relay digital outputs	4 x 2A 250V~	4 x 2A 250V~	4 x 2A 250V~
analogue outputs	2 x Open Collector PWM/D.I. 2 x 0...10V 1 x 4...20mA / 0...20mA	2 x Open Collector PWM/D.I. 2 x 0...10V 1 x 4...20mA / 0...20mA	2 x Open Collector PWM/D.I. 2 x 0...10V 1 x 4...20mA / 0...20mA
analogue inputs	3 x NTC / Pt1000 / D.I.	3 x NTC / Pt1000 / D.I.	3 x NTC / D.I.
connectivity	TTL RS485 LAN for connection to SKP/SKW terminal or to SME expansion module	TTL RS485 LAN for connection to SKP/SKW terminal or to SME expansion module	TTL - LAN for connection to FREE Smart
operating temperature	-20...+55°C	-20...+55°C	-20...+55°C

Wiring diagrams

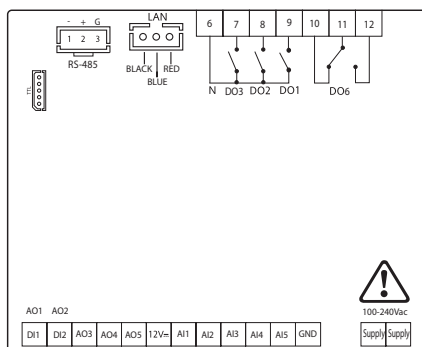

SMD4500/C/S - SMC4500/C/S

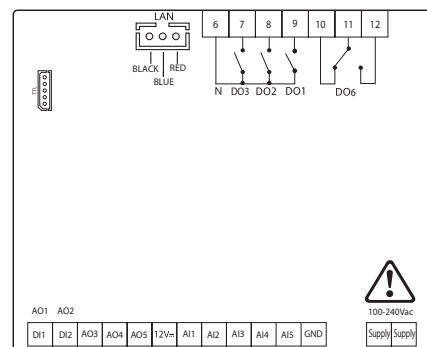

SME4500 expansion module

Interfaces, FREE Smart terminals



SKP10



SKW22/22L



SKP22

Technical Data

	SKP10	SKW22 - SKW22L	SKP22
format (LxDxH)	74x32x30 mm	4DIN	4DIN
mounting	Panel	Wall	Panel
display	LED 4 digits - 7 segments	LCD (model 22L : backlit LCD)	LCD
power supply	From base	From base	From base
analogue inputs	-	1 x integrated NTC	1 x remote NTC
	-	1 x NTC/ D.I. / 0...20mA / 4...20mA remote	1 x NTC/ D.I. / 0...20mA / 4...20mA remote
connectivity	LAN for connection to FREE Smart	LAN for connection to FREE Smart	LAN for connection to FREE Smart
wiring	cable COLV000033200 Included in the package	cable COLV000033200 Included in the package	cable COLV000033200 Included in the package
operating temperature	-20...+55°C	-5...+60°C	-5...+60°C
humidity module	-	KP100000 - not included (see Accessories page)	-

Wiring and assembly diagrams

The diagram section includes the following components:

- SKP10 Dimensions:** A 3D view of the device with dimensions: 70mm width, 30mm height, 74mm depth, and 32mm mounting hole offset.
- SKW22(L) Dimensions:** A 3D view of the device with dimensions: 71mm width, 30mm height, and 28mm mounting hole offset.
- SKW22(L) Wiring:** Shows connections for Remote Probe (black/GND, blue/signal, red/+12Vdc), LAN, and Digital input. It notes the possibility of powering the transducer via the +12Vdc terminal. A note states: "PROBE NOT INCLUDED / SONDE NON INCLUDE".
- SKP22(L) Dimensions:** A 3D view of the device with dimensions: 138mm width, 68mm height, 150mm depth, and 84mm mounting hole offset.
- SKP22(L) Wiring:** Shows connections for GND, AIRT, AIR2, and Probes (B, L, A, C, K and B, L, U, E).
- SKW22(L) Internal Wiring:** Shows connections for red/+12Vdc, green/signal, and black/GND, along with an RH Sensor (RH Optional Module).

FREE Panel models

FREE Panel (EVP) is the solution with LCD display that can be used as a system controller, with gateway functions, used in association with other FREE Evolution and FREE Smart or third-party controllers.

FREE Panel guarantees high performance in terms of memory, user interface, Master/Slave connectivity as well as expandability (by CANbus 'field' up to 12 expansion modules), straightforward programming, maintenance, and servicing.

A special backplate is available as an accessory for wall-mounting.



FREE Panel

FREE Panel /C indicates the presence of the RTC - Real Time Clock. /RH: humidity sensor

Model	Code	Installation	Display	Inputs safety extra low voltage SELV	Serial
EVP3300/C	EVP3300010B00	Panel (for wall-mounting see Accessories page)	LCD backlit	1 x NTC integrated; 1 x NTC remote; 1 x 4...20mA / 0-5V / 0-10V remote	CANbus; RS485; Ethernet
EVP3300/C/RH	EVP3500010B00	Panel (for wall-mounting see Accessories page)	LCD backlit	1 x NTC integrated; 1 x NTC remote; 1 x integrated %RH	CANbus; RS485; Ethernet

KEY: SELV = Safety Extra Low Voltage

Technical Data

	EVP3300/C	EVP3300/C/RH
format	160x96x10mm	160x96x10mm
display	LCD graphic display 128x64px backlit	LCD graphic display 128x64px backlit
power supply	24V~/~ - 48V~	24V~/~ - 48V~
analogue inputs	AI1 1 x integrated NTC	AI1 1 x integrated NTC
	AI2 1 x remote NTC / D.I.	AI2 1 x remote NTC / D.I.
	AI3 1 x 4...20mA / 0-5V / 0-10V remote	AI4 1 x integrated %RH
connectivity	CANBus: CANopen	CANBus: CANopen
	RS485: Modbus RTU, BACnet MSTP	RS485: Modbus RTU, BACnet MSTP
	Ethernet: Modbus TCP - BACnet IP - HTTP	Ethernet: Modbus TCP - BACnet IP - HTTP
operating temperature	-5...+55°C	-5...+55°C

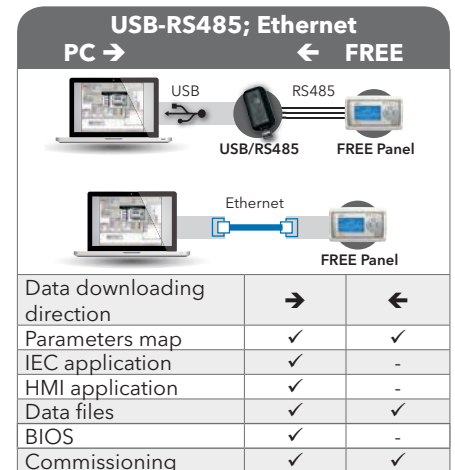

Wiring, assembly and connectivity diagrams

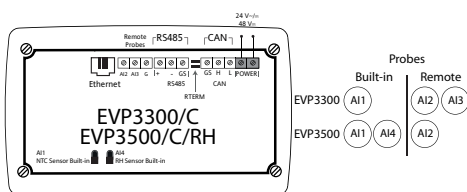
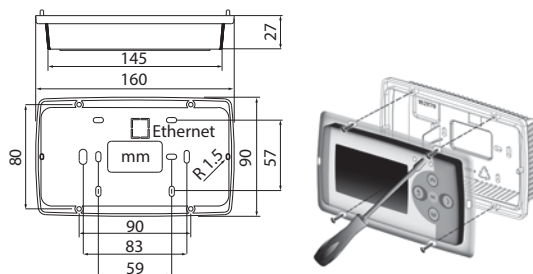

EVP3300/C - EVP3300/C/RH

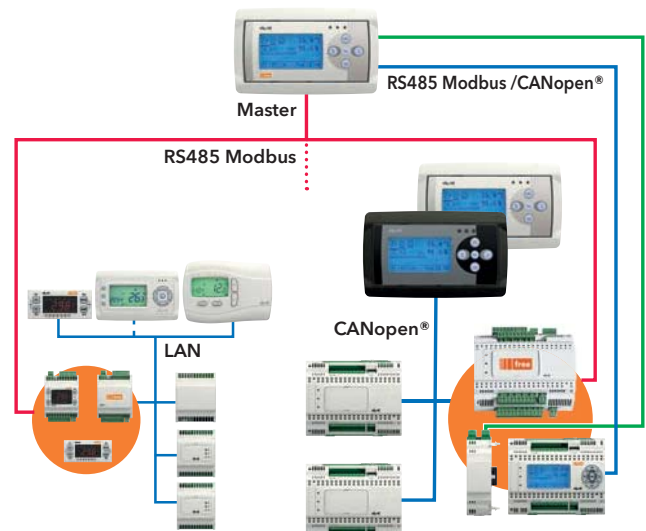

FREE Smart, FREE Panel and FREE Evolution connectivity

FREE Advance models



FREE Advance

FREE Advance models (**AVD** with display, **AVC** without display) are available in the 8 DIN rail-mounted version, with removable screw terminals to make installation easier and faster.

Each AVD or AVC can be expanded by CANbus (field) up to 12 expansion modules and 2 terminals (EVK). By CANbus (network) it is also possible to connect up to 10 controllers to one another.

Up to 127 devices can be managed with the Modbus Master, by RS485.

FREE Advance with or without display /C indicates the presence of the RTC - Real Time Clock; RS485 and CANbus integrated as standard

Model	Code	Relay outputs dangerous voltage	SSR Outputs	Analogue outputs low voltage SELV	Digital inputs safety extra low voltage SELV Including 2 high-speed pulse / frequency counters up to 2 kHz	Analogue inputs safety extra low voltage SELV
AVC8400/C/L/U	AVC8400060500	8		4	8	8
AVD8400/C/L/U	AVD8400060500	8		4	8	8
AVD8400/C/L/U/SSR	AVD84SS060500	6	2	4	8	8
AVC12600/C/L/U	AVC1260060500	12		6	12	12
AVD12600/C/L/U	AVD1260060500	12		6	12	12
AVD12600/C/L/U/SSR	AVD126S060500	10	2	6	12	12

Expansion modules RS485 (only EVE7500) and CANbus integrated as standard

Model	Code	Relay outputs dangerous voltage	SSR Outputs	Analogue outputs safety extra low voltage SELV A04/A05 configurable as Open Collector 12V \approx 100mA max each	Digital inputs safety extra low voltage SELV	Digital inputs no voltage	Analogue inputs safety extra low voltage SELV
EVE7500	EVE7500000B00	7	-	5	8	1*	6
EVE4200	EVE4200000500	4	-	2	4	-	4

*high-speed pulse/ frequency counter 1 kHz

Terminals

Model	Code	Installation	Dimensions	Display	Serial
EVK1000	EVK1000000B00	Panel (for wall-mounting see Accessories page)	160x96x10mm	Backlit LCD	CANBus

Plug-in 2DIN models; power supply from the base AVD / AVC

Model	Code	Output dangerous voltage	Connectivity protocol
EVS RS232	EVS10R2000000	1 x SPDT 5A 250V~	Modbus ASCII
EVS RS485	EVS00R4000000	-	Modbus RTU
EVS CAN	EVS00CA000000	-	CANopen
EVS BACnet	EVS00BM000000	-	Modbus RTU - BACnet MSTP
EVS LONWORKS	EVS0LON000000	-	LON

KEY: SSR = Solid State Relay; SELV = Safety Extra Low Voltage

Resources Available - FREE Advance

The IEC programmer includes the following resources:

CPU	120MHz, 32MB RAM
Available memory for Application	1 MByte
Available memory for User Interface	1.5 MByte
FLASH memory data	8 MByte
RAM memory - automatic mapping	512 KByte
RAM memory - Modbus mapping	5000 word
EEPROM variables	4000 word (application) + 10000 word (BACnet objects)

Minimum kit for the developer - FREE Advance

- FREE Studio installation setup.
- 1 FREE Advance AVD8400/C/L/U
- Mini-USB cable for PC connection
- Ethernet cable for network connection
- FREE Advance power transformer

FREE Advance connectivity

FREE Advance models have ETHERNET and RS-485 and CANbus serials as standard. They can be integrated into industrial systems and BMS and through the range of plug-ins and 2DIN modules that connect quickly and intuitively to the main AVD/AVC module.

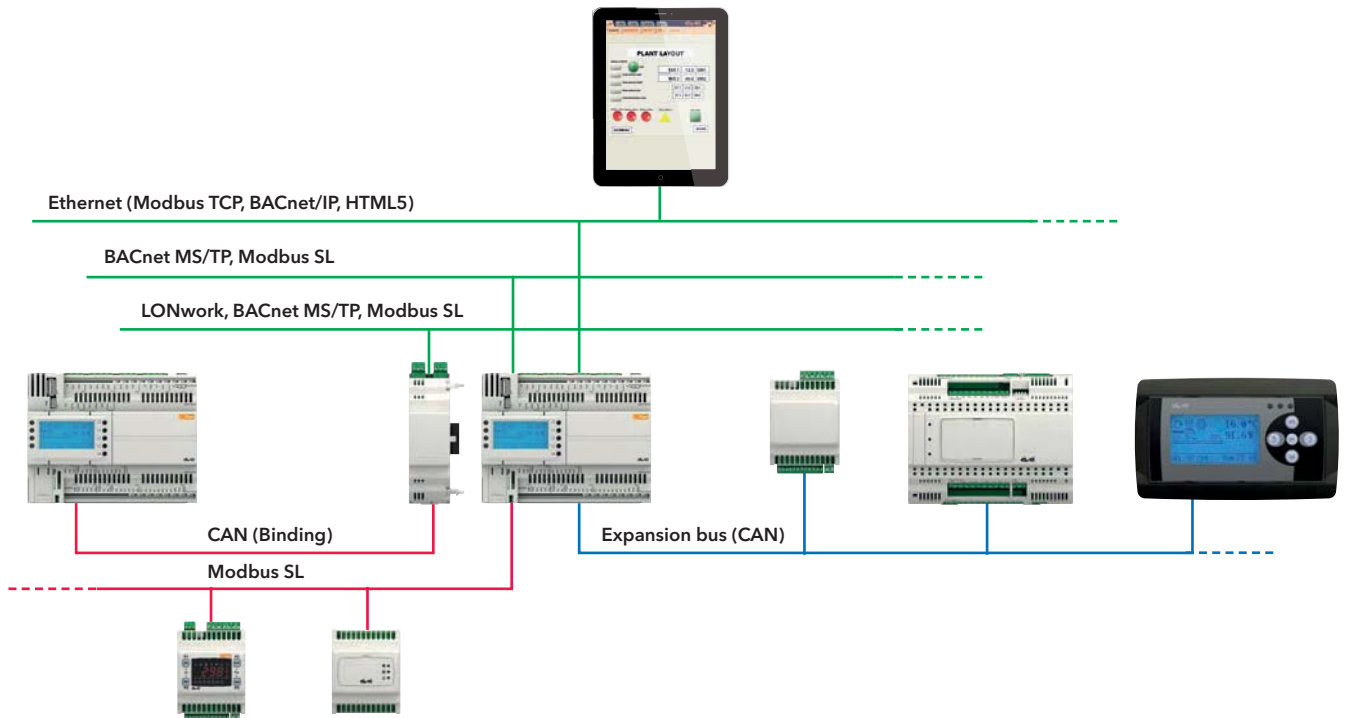

Connectivity and functionality

Advance FREE controllers are equipped with advanced capabilities, incorporating Ethernet, Modbus and BACnet IP protocols as standard, in addition to the optional LON protocol by plug-in.

Internet and integrated Web Server connection offer machine builders and system integrators complete remote access, drastically reducing support and maintenance costs.

This is also beneficial for end users, who can control their system from multiple devices.

- Integrated WebServer
- Local and remote system control, including alarms management and e-mail notifications.
- Remote reading and support.
- Preventive and predictive maintenance.
- Next generation system interface on PC, Tablet and Smartphone

SD card Datalogging
SD card → ← FREE

Data downloading direction	→	←
Parameters map	-	-
IEC application	✓	
HMI application		
Data files		
BIOS	-	-

USB Host
PC → ← FREE

Data downloading direction	→	←
Parameters map	✓	✓
IEC application	✓	✓
HMI application	✓	✓
Data files	✓	✓
BIOS	✓	-

Ethernet / USB Device / RS485
PC → ← FREE

Data downloading direction	→	←
Parameters map	✓	✓
IEC application	✓	-
HMI application	✓	-
Data files	✓	✓
BIOS	✓	-

AVD8400, AVD8400 SSR, AVC8400



AVD8400



AVD8400 SSR



AVC8400

Technical Data

	AVD8400	AVD8400 SSR	AVC8400
format	8DIN	8DIN	8DIN
display	128x64 pixel graphic LCD backlit	128x64 pixel graphic LCD backlit	-
power supply	+24V~ not insulated +20...+38VC not insulated	+24V~ not insulated +20...+38VC not insulated	+24V~ not insulated +20...+38VC not insulated
digital outputs	8: 7 x 3A, 1 x 1A 250V~ -	6: 5 x 3A, 1 x 1A 250V~ SSR: 2 x 0.5A 240V~	8: 7 x 3A, 1 x 1A 250V~ -
analogue outputs	4: 2 x 0-10V, 2 x 0-10V / 4...20mA / ON-OFF / PWM / O.C. 24VC 30mA max	4: 2 x 0-10V, 2 x 0-10V / 4...20mA / ON-OFF / PWM / O.C. 24VC 30mA max	4: 2 x 0-10V, 2 x 0-10V / 4...20mA / ON-OFF / PWM / O.C. 24VC 30mA max
digital inputs	6 x safety extra low voltage SELV 2 x pulse / frequency counter up to 2 kHz	6 x safety extra low voltage SELV 2 x pulse / frequency counter up to 2 kHz	6 x safety extra low voltage SELV 2 x pulse / frequency counter up to 2 kHz
analogue inputs	8 x NTC 103AT / NTC NK103 / D.I. / PTC KTY81 / Pt1000 / 0...20 mA / 4...20 mA / 0-10V / 0-5V	8 x NTC 103AT / NTC NK103 / D.I. / PTC KTY81 / Pt1000 / 0...20 mA / 4...20 mA / 0-10V / 0-5V	8 x NTC 103AT / NTC NK103 / D.I. / PTC KTY81 / Pt1000 / 0...20 mA / 4...20 mA / 0-10V / 0-5V
connectivity	USB; 1 x plug-in EVS ETHERNET: BACnet IP CANBus: CANopen 2 x RS485: Modbus RTU (including 1 x RS485: also BACnet MS/TP)	USB; 1 x plug-in EVS ETHERNET: BACnet IP CANBus: CANopen 2 x RS485: Modbus RTU (including 1 x RS485: also BACnet MS/TP)	USB; 1 x plug-in EVS ETHERNET: BACnet IP CANBus: CANopen 2 x RS485: Modbus RTU (including 1 x RS485: also BACnet MS/TP)
operating temperature	-20...+60°C	-20...+60°C	-20...+60°C

Wiring and assembly diagrams

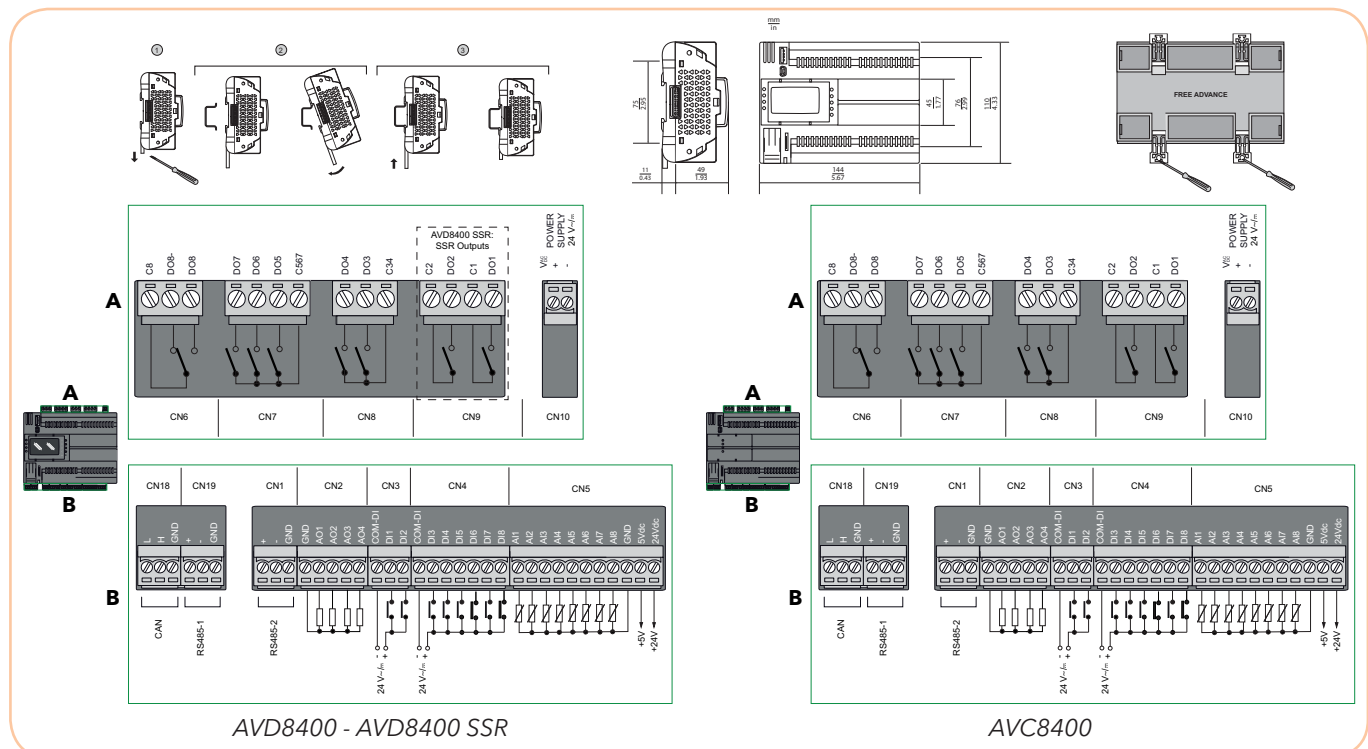

AVD12600, AVD12600 SSR, AVC12600



AVD12600



AVD12600 SSR



AVC12600

Technical Data

	AVD12600	AVD12600 SSR	AVC12600
format	8DIN	8DIN	8DIN
display	128x64 pixel graphic LCD backlit	128x64 pixel graphic LCD backlit	-
power supply	+24V~ not insulated +20...+38V~ not insulated	+24V~ not insulated +20...+38V~ not insulated	+24V~ not insulated +20...+38V~ not insulated
digital outputs	12 : 10 x 3A, 2 x 1A 250V~	10 : 8 x 3A, 2 x 1A 250V~ SSR : 2 x 0.5A 240V~	10 : 8 x 3A, 2 x 1A 250V~
analogue outputs	6 : 4 x 0-10V, 2 x 0-10V / 4...20mA / ON-OFF / PWM / O.C. 24V~ 30mA max	6 : 4 x 0-10V, 2 x 0-10V / 4...20mA / ON-OFF / PWM / O.C. 24V~ 30mA max	6 : 4 x 0-10V, 2 x 0-10V / 4...20mA / ON-OFF / PWM / O.C. 24V~ 30mA max
digital inputs	10 x safety extra low voltage SELV 2 x pulse / frequency counter up to 2 kHz	10 x safety extra low voltage SELV 2 x pulse / frequency counter up to 2 kHz	10 x safety extra low voltage SELV 2 x pulse / frequency counter up to 2 kHz
analogue inputs	12 x NTC 103AT / NTC NK103 / D.I. / PTC KTY81 / Pt1000 / 0...20 mA / 4...20 mA / 0-10V / 0-5V	12 x NTC 103AT / NTC NK103 / D.I. / PTC KTY81 / Pt1000 / 0...20 mA / 4...20 mA / 0-10V / 0-5V	12 x NTC 103AT / NTC NK103 / D.I. / PTC KTY81 / Pt1000 / 0...20 mA / 4...20 mA / 0-10V / 0-5V
connectivity	USB; 1 x plug-in EVS ETHERNET: BACnet IP CANBus: CANopen 2 x RS485: Modbus RTU (including 1 x RS485: also BACnet MS/TP)	USB; 1 x plug-in EVS ETHERNET: BACnet IP CANBus: CANopen 2 x RS485: Modbus RTU (including 1 x RS485: also BACnet MS/TP)	USB; 1 x plug-in EVS ETHERNET: BACnet IP CANBus: CANopen 2 x RS485: Modbus RTU (including 1 x RS485: also BACnet MS/TP)
operating temperature	-20...+60°C	-20...+60°C	-20...+60°C

Wiring and assembly diagrams

The diagrams illustrate the wiring and assembly for three device models: AVD12600, AVD12600 SSR, and AVC12600 SSR. They include terminal block layouts, connection points for power supply, digital outputs, analogue outputs, digital inputs, analogue inputs, and connectivity (CAN, RS485, Ethernet). Dimensions and assembly instructions are also provided.

AVD12600 - AVD12600 SSR

AVC12600 SSR

FREE Evolution models



FREE Evolution

FREE Evolution models (**EVD** with display, **EVC** without display) are available in the 8 DIN rail-mounted version, with removable screw terminals to make installation easier and faster.

Each EVD or EVC can be expanded by CANbus (field) up to 12 expansion modules and 2 terminals (EVK). By CANbus (network) it is also possible to connect up to 10 controllers to one another.

Up to 127 devices can be managed with the Modbus Master, by RS485.

FREE Evolution with or without display /C indicates the presence of the RTC - Real Time Clock; RS485 and CANbus integrated as standard

Model	Code	Relay outputs dangerous voltage	SSR Outputs	Analogue outputs safety extra low voltage SELV A04/A05 configurable as Open Collector 12V \approx 100mA max each	Digital inputs safety extra low voltage SELV	Digital inputs no voltage	Analogue inputs safety extra low voltage SELV
EVD7500/C/U	EVD7500060B00	7	-	5	8	1*	6
EVD75SS/C/U	EVD75SS060B00	5	2	5	8	1*	6
EVC7500/C/U	EVC7500060B00	7	-	5	8	1*	6

*Fast counter 1KHz

Expansion modules RS485 (only EVE7500) and CANbus integrated as standard

Model	Code	Relay outputs dangerous voltage	SSR Outputs	Analogue outputs safety extra low voltage SELV A04/A05 configurable as Open Collector 12V \approx 100mA max each	Digital inputs safety extra low voltage SELV	Digital inputs no voltage	Inputs inputs safety extra low voltage SELV
EVE7500	EVE7500000B00	7	-	5	8	1*	6
EVE4200	EVE4200000500	4	-	2	4	-	4

*Fast counter 1KHz

Terminals

Model	Code	Installation	Dimensions	Display	Serial
EVK1000	EVK1000000B00	Panel (for wall-mounting see Accessories page)	160x96x10mm	Backlit LCD	CANBus

Plug-in 2DIN models; power supply from the base EVD / EVC

Model	Code	Output dangerous voltage	Connectivity protocol
EVS RS232	EVS10R2000000	1 x SPDT 5A 250V~	Modbus ASCII
EVS RS485	EVS00R4000000	-	Modbus RTU
EVS CAN	EVS00CA000000	-	CANopen
EVS ETH	EVS00ET000000	-	Modbus TCP - BACnet IP - HTTP
EVS Profibus	EVS00PB000000	-	Profibus DP Slave-V0
EVS Bacnet	EVS00BM000000	-	Modbus RTU - BACnet MSTP
EVS ETH/RS485	EVS00EB000000	-	Modbus RTU - BACnet MSTP - Modbus TCP - BACnet IP - HTTP
EVS LONWORKS	EVS0LON000000	-	LON

KEY: SSR = Solid State Relay; SELV = Safety Extra Low Voltage

Resources available - FREE Panel, FREE Evolution

The IEC programmer includes the following resources:

CPU	72 MHz, 32MB RAM
Available memory for Application	1 MByte
Available memory for User Interface	1.5 MByte
FLASH memory data	128 MByte
RAM memory - automatic mapping	512 KByte
RAM memory - Modbus mapping	5000 word
EEPROM variables	4000 word (application) + 10000 word (BACnet objects)

Minimum kit for the developer - FREE Evolution

- FREE Studio installation setup.
- 1 FREE Evolution EVD7500/C/U
- USB/RS485 converter or Ethernet plug-in for PC connection
- FREE Evolution power transformer

FREE Evolution connectivity

FREE Evolution models have RS-485 and CANbus serials integrated as standard. They can be integrated into industrial systems, BMS and Ethernet networks through the range of plug-ins and 2DIN modules that connect quickly and intuitively to the main EVD/EVC module.

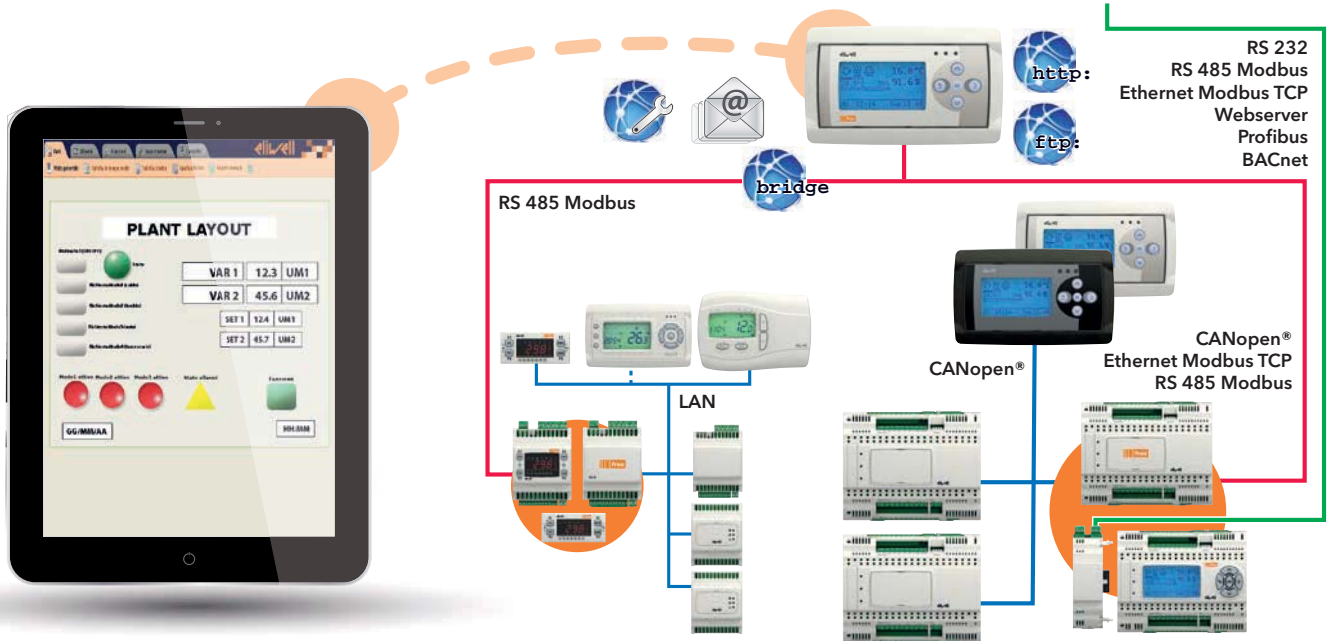

WEB functionalities

FREE Evolution and FREE Panel are WEB-enabled, giving machine manufacturers and system integrators integral remote access.

Having a web-based connection in machines significantly reduces support and maintenance costs.

This is also beneficial for end users, who can control their system from multiple devices.

- Web-based access.
- Remote reading and support.
- Local and remote system control, including alarms management.
- Preventive and predictive maintenance.
- Email alarm alerts.
- Next generation system interface on PC, Tablet and Smartphone

USB Host		FREE	
USB →	←		
Data downloading direction	→	←	
Parameters map	✓	✓	
IEC application	✓	✓	
HMI application	✓	✓	
Data files	✓	✓	
BIOS	✓	-	
Commissioning	-	-	

USB Device		FREE	
PC →	←		
Data downloading direction	→	←	
Parameters map	-	-	
IEC application	✓	✓	
HMI application	✓	✓	
Data files	✓	✓	
BIOS	✓	-	
Commissioning	✓	✓	

USB-RS485 / Ethernet + Plugin		FREE	
PC →	←		
Data downloading direction	→	←	
Parameters map	✓	✓	
IEC application	✓	-	
HMI application	✓	-	
Data files	✓	✓	
BIOS	✓	-	
Commissioning	✓	✓	

EVD7500, EVD75SS, EVC7500



EVD7500



EVD75SS



EVC7500

Technical Data

	EVD7500	EVD75SS	EVC7500
format	8DIN	8DIN	8DIN
display	128x64 pixel graphic LCD backlit	128x64 pixel graphic LCD backlit	-
power supply	24V~/- 48V~	24V~/- 48V~	24V~/- 48V~
digital outputs	7 : 2 x 8A, 5 x 5A 250V~	5 : 2 x 8A, 3 x 5A 250V~	7 : 2 x 8A, 5 x 5A 250V~
analogue outputs	5 x 0-10V / 4...20mA / (switch 0..20mA) A04/A05 configurable as O.C. 12V~ 100mA max each	5 x 0-10V / 4...20mA / (switch 0..20mA) A04/A05 configurable as O.C. 12V~ 100mA max each	5 x 0-10V / 4...20mA / (switch 0..20mA) A04/A05 configurable as O.C. 12V~ 100mA max each
digital inputs	8 safety extra low voltage SELV 1 x Fast voltage-free counter 1KHz	8 safety extra low voltage SELV 1 x Fast voltage-free counter 1KHz	8 safety extra low voltage SELV 1 x Fast voltage-free counter 1KHz
analogue inputs	2 x NTC 103AT / NTC NK103 / DI 4 x NTC 103AT / NTC NK103 / DI / Pt1000 / 4...20 mA / 0-10V / 0-5V	2 x NTC 103AT / NTC NK103 / DI 4 x NTC 103AT / NTC NK103 / DI / Pt1000 / 4...20 mA / 0-10V / 0-5V	2 x NTC 103AT / NTC NK103 / DI 4 x NTC 103AT / NTC NK103 / DI / Pt1000 / 4...20 mA / 0-10V / 0-5V
connectivity	USB; 1 x Plug-in EVS CANBus: CANopen RS485: Modbus RTU	USB; 1 x Plug-in EVS CANBus: CANopen RS485: Modbus RTU	USB; 1 x Plug-in EVS CANBus: CANopen RS485: Modbus RTU
operating temperature	-10...+55°C	-10...+55°C	-10...+55°C

Wiring and assembly diagrams

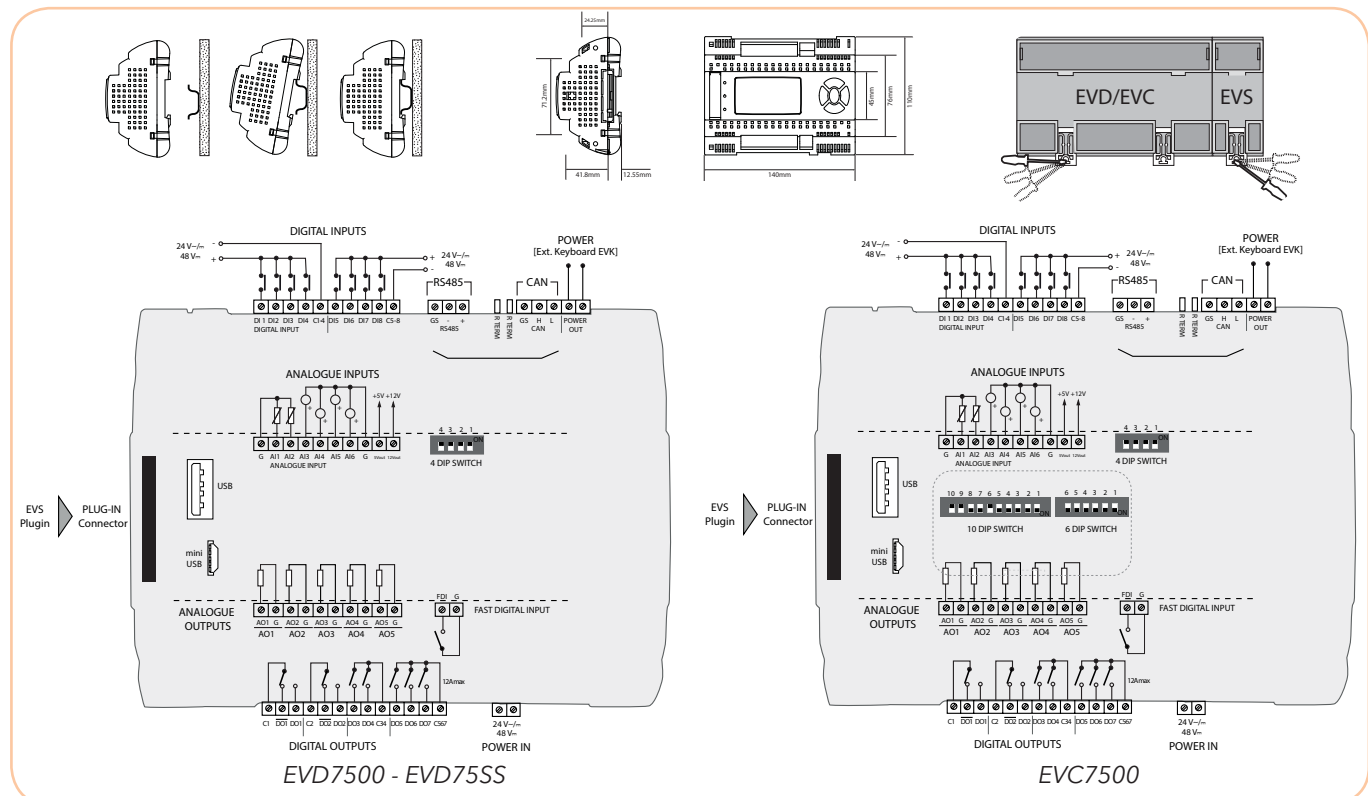

Expansion modules EVE, Terminal EVK, Plugin EVS



EVE7500



EVE4200



EVK1000



EVS

Technical Data

	EVE7500	EVE4200	EVK1000	EVS
format	8DIN	4DIN	160x96x10mm	see table pg. 13 (FREE Advance) pg. 17 (FREE Evolution)
mounting	on DIN rail	on DIN rail	panel-mounted (for wall-mounting see Accessories page)	
display	-	-	Backlit LCD	
power supply	24V~/± - 48V±	24V~/± not insulated	12...24V~ / 24V±	
digital outputs	2 x 8A 250V~ 5 x 5A 250V~	1 x 5A 250V~ 3 x 3A 250V~	-	
analogue outputs	5 x 0-10V / 4..20mA / switch 0..20mA	2 x 0-10V	-	
digital inputs	8 safety extra low voltage SELV 1 x Fast voltage-free counter 1KHz	4 safety extra low voltage SELV	-	
analogue inputs	2 x NTC 103AT / NTC NK103 / DI 4 x NTC 103AT / NTC NK103 / DI / Pt1000 / 4...20 mA / 0-10V / 0-5V	4 x NTC 103AT / NTC NK103 / DI / Pt1000 / PTC / 4...20 mA / 0-10V / 0-5V	-	
connectivity	CANBus: CANopen RS485: Modbus RTU 1 x EVS Plugin (solo EVS RS485, EVS CAN)	CANBus*: CANopen *CANbus / TTL not insulated	CANBus: CANopen	
operating temperature	-10...+55°C	-10...+55°C	-5...+55°C	

Wiring, assembly and dimensional diagrams

EVE7500

EVE4200

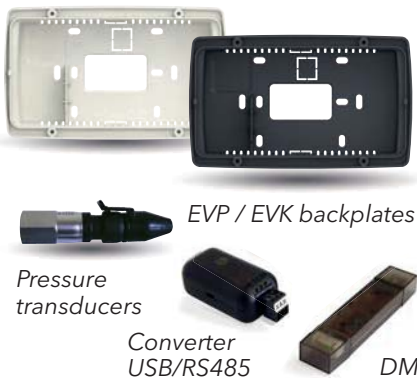

In association with FREE Smart, FREE Panel and FREE Evolution Eliwell supplies a wide range of accessories, from the protected transformer to IP68 temperature probes, pressure/ratiometric transducers and pressure switches.

Single-phase (with a current from 2 to 9A) and three-phase fan modules are also available.

The connection of ratiometric pressure sensors, external modules (e.g. fan modules) and terminals does not require the use of any other serial interfaces.

	Code	Description	Details
Converters, interfaces, programming keys			
	SAR0RA00X701	USB/485 MINI KIT converter	-
	EVA00USCA0000	USB/CAN converter	FREE Evolution / FREE Advance
	DMI1003002000	Interface module DMI100-3 Manufacturer	FREE Smart only
	MFK100T000000	MFK: programming key for uploading/downloading parameters, applications	FREE Smart only
Wiring			
	COLV0000E0100	Wiring for I/O connection - safety extra low voltage SELV - 1 m cable	FREE Smart only 12...24V
	COLV000035100	Wiring RS485	FREE Smart only 12...24V
	COLV000042100	Wiring AO3-4-5 - cable 1m	FREE Smart only 12...24V
Connectivity			
	BA1000R3700	BusAdapter 150 TTL-RS485	FREE Smart only
Backplates			
	EVA00WMRC0000	White backplate kit (4 pcs) for wall mounting.	For EVP/EVK
	EVA00WMRC0001	Black backplate kit (4 pcs) for wall mounting.	For EVP/EVK
Humidity module			
	KP100000	%RH Humidity module	For SKW terminal
Demo Case			
	VAL00031K	Demo Case for FREE Smart	-
	VAL00033K	Demo Case for FREE Evolution	-
Temperature probes*			
	SN8DED11502C0	NTC 103AT 5X20 1.5m TPE IP68	-
	SN8DAE11502C0	NTC 103AT 6X20 1.5m TPE IP68	-
	SN9DAE11502C6	Pt1000 6X20 1.5m IP68	FREE Smart 4500 / FREE Evolution / FREE Advance
	SN9DED11502C6	Pt1000 5X20 1.5m IP68	Evolution / FREE Advance
Transformers			
	TF411205	230V~/12V 6VA transformer (protected)	FREE Smart only
	TF411210	230V~/12V 11VA transformer (protected)	FREE Smart only
	TF111211	220V~/24V-24V 16VA transformer	FREE Smart only
	TF111202	230V~/24V 25VA transformer	FREE Evolution only
	TF111205	230V~/24V 35VA transformer. Mounting on DIN rail	FREE Evolution / FREE Advance
Pressure transducers			
	TD220050	EWPA050 4...20mA / 0...667 psi / 0..50bar IP54** 2m cable	1/4 SAE MALE
	TD220007	EWPA007 4...20mA / -7...101.5 psi / -0.5..7bar IP54** 2m cable	1/4 SAE MALE
	TD320050	EWPA050 4...20mA / 0...667 psi / 0..50bar IP54** 2m cable	1/4 SAE FEMALE
	TD320007	EWPA007 4...20mA / -7...101.5 psi / -0.5..7bar IP54** 2m cable	1/4 SAE FEMALE
Ratiometric transducers			
	TD420010	EWPA 010 R 0...145 psi / 0...10bar IP67 2m cable (Packard connector)	Female connector
	TD420030	EWPA 030 R 0...508 psi / 0...30bar IP67 2m cable (Packard connector)	Female connector
	TD420050	EWPA 050 R 0...667 psi / 0...50bar IP67 2m cable (Packard connector)	Female connector
Expansion modules, fan modules			
	MW320100	EXP11 250V 10A expansion module with DIN rail-mounted base	Open Collector Output
	MW991012	CFS05 TANDEM TRIAC 5+5A 250V	-
	CFS modules	CFS - Single-phase speed regulators for currents from 2A to 9A	Various codes available

KEY: SELV = Safety Extra Low Voltage

*different cable lengths available on request **version IP67 with optional Packard connector

Life Is On



Eliwell Controls Srl

Via dell'Industria, 15 Z. I. Paludi
32010 Pieve d'Alpago (BL) - ITALY
+39 0437 986 111

Sales

+39 0437 986 100 (Italy)
+39 0437 986 200 (other countries)
saleseliwell@schneider-electric.com

Technical support

+39 0437 986 250
eliwell.freeway@schneider-electric.com



CT123302 - EN - rel. 05/16
© Copyright Eliwell Controls s.r.l. 2016 - All rights reserved

Follow us on



www.eliwell.com

For more than 35 years, Eliwell has been offering control systems and services for refrigeration and air conditioning units, both commercial and industrial, with highly innovative and technologically advanced products. Eliwell is part of Schneider Electric. Subscribe to our newsletter on the site www.eliwell.com.