

EWPlus 961/971/974

Electronic controllers for refrigeration units



USER INTERFACE







EW^{PLUS} 961







EW^{PLUS} 971/974

NOTE:

When switched on, the device performs a Lamp Test; the display and LEDs will flash for several seconds to check that they all function correctly.

	Reduced SET / Economy LED Permanently on: Energy Saving active Flashing: Reduced SET active Quick flashing: access to level2 parameters Off: otherwise		Fans LED Permanently on: fans active Off: otherwise
	Compressor LED Permanently on: compressor active Flashing: a delay, a protection or a locked start-up Off: otherwise	AUX	Aux LED Permanently on: Aux output active Flashing: Deep Cooling cycle active Off: Aux output not active
	Defrost LED Permanently on: defrost active Flashing: manual or D.I. activation Off: otherwise	1	HEAT mode LED Permanently on: compressor in HEAT mode Off: otherwise (only EWPlus 961)
°C	°C LED Permanently on: °C setting (dro = 0) Off: otherwise	NOTE: If the instrument is set in the COOL mode, in order to use it in the HEAT mode it is necessary to reprogramme the instrument by using the properly programmed Copycard. The same procedure should be followed to pass from the HEAT mode to the COOL mode.	
°F	°F LED Permanently on: °F setting (dro = 1) Off: otherwise		
	Alarm LED Permanently on: alarm active Flashing: alarm acknowledged Off: otherwise	2	NOT USED (only EWPlus 961)

KEYs

			
UP Press and release • Scroll menu items • Increases values Press for at least 5 sec • Activates the Manual Defrost function	DOWN Press and release • Scroll menu items • Decrease values Press for at least 5 sec • Function can be configured by the user ((see parameter H32))	STAND-BY (ESC) Press and release • Returns to the previous menu level • Confirms parameter value Press for at least 5 sec • Attiva la funzione Stand-by (OFF) (quando non sono all'interno dei menu)	SET (ENTER) Press and release • Displays alarms (if active) • Opens Machine Status menu Press for at least 5 sec • Opens Programming menu • Confirm commands

MOUNTING - DIMENSIONS

The device is designed for panel mounting. Drill a 29x71 mm hole and insert the instrument; secure it with the special brackets provided. Do not install the instrument in damp and/or dirty places; in fact, it is suitable for use in places with ordinary or normal levels of pollution. Keep the area around the instrument cooling slots adequately ventilated.

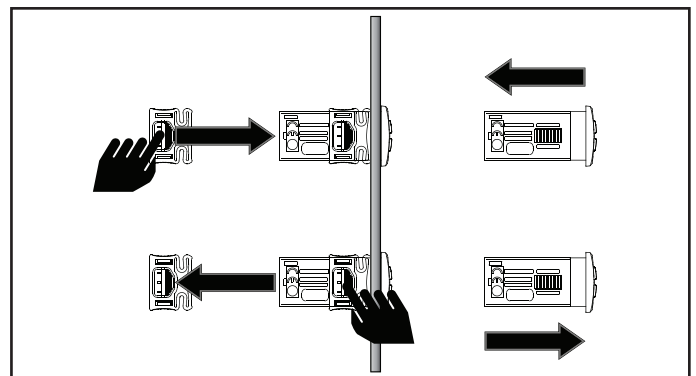
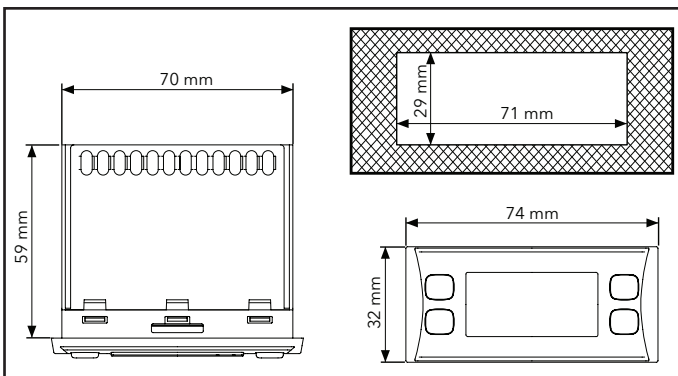

CONNECTIONS

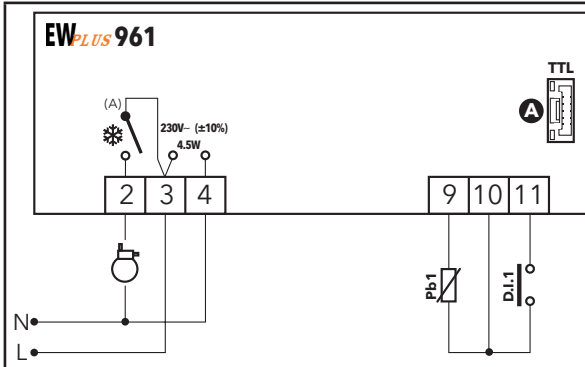

EWPlus 961 TERMINALS	
3-2	Compressor relay (❄️)
3-4	230V~ power supply input
10-9	Pb1 probe
10-11	Digital Input 1
N-L	230V~ power supply
TTL	TTL input

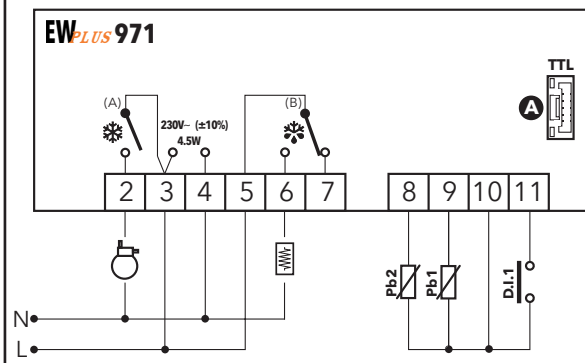

EWPlus 971 TERMINALS	
3-2	Compressor relay (❄️)
3-4	230V~ power supply input
5-6	N.O. Defrost relay (❄️)
5-7	N.C. Defrost relay (❄️)
10-8	Pb2 probe
10-9	Pb1 probe
10-11	Digital Input 1
N-L	230V~ power supply
TTL	TTL input

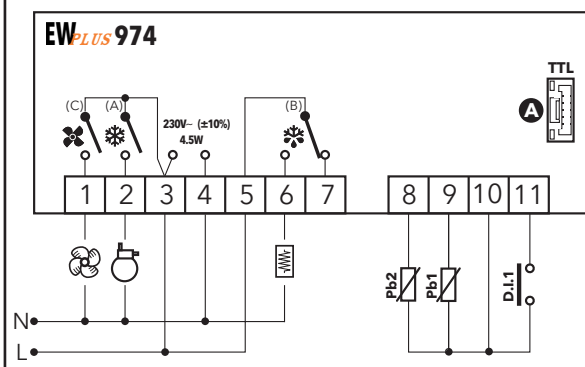

EWPlus 974 TERMINALS	
3-1	Fans relay (🌀)
3-2	Compressor relay (❄️)
3-4	230V~ power supply input
5-6	N.O. Defrost relay (❄️)
5-7	N.C. Defrost relay (❄️)
10-8	Pb2 probe
10-9	Pb1 probe
10-11	Digital Input 1
N-L	230V~ power supply
TTL	TTL input

ECPLUS + EWPLUS CONNECTIONS

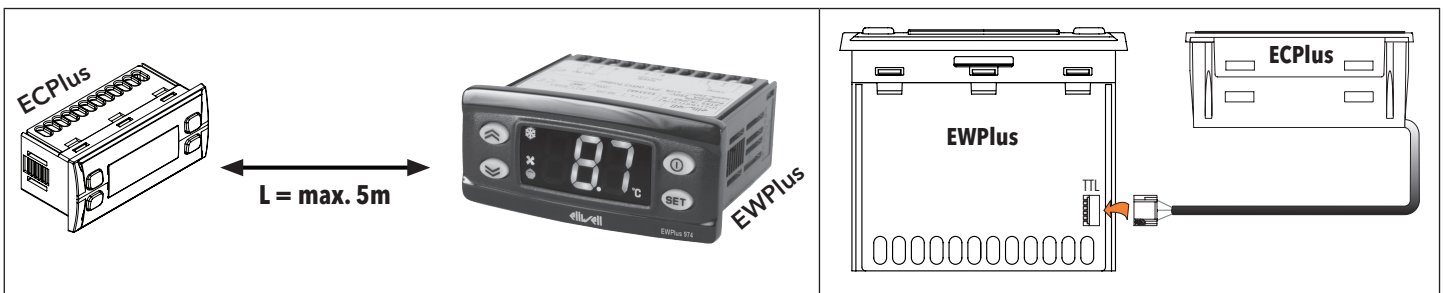

PASSWORD

Password PA1: used to access "User" parameters. The password is not enabled by default (**PA1=0**).

To enable it (**PA1≠0**): press and hold **set** for longer than 5 seconds, scroll through the parameters using **⏪** and **⏩** until you see the label **PS1**, press **set** to display the value, modify it using **⏪** and **⏩**, then save it by pressing **set** or **⏻**.
If enabled, it will be required in order to access the User parameters.

Password PA2: used to access "Installer" parameters. The password is enabled by default (**PA2=15**).

To modify it (**PA2≠15**): press and hold **set** for longer than 5 seconds, scroll through the parameters using **⏪** and **⏩** until you see the label **PA2**, press **set**, set the value to "15" using **⏪** and **⏩**, then confirm using **set**. Scroll through the folders until you find the label **dis** and press **set** to enter. Scroll through the parameters using **⏪** and **⏩** until you see the label **PS2**, press **set** to display the value, modify it using **⏪** and **⏩**, then save it by pressing **set** or **⏻**. The visibility of **PA2** is as follows:

- PA1 & PA2 ≠ 0:** Press and hold **set** for longer than 5 seconds to display **PA1** and **PA2**. It will then be possible to decide whether to access the "User" parameters (**PA1**) or the "Installer" parameters (**PA2**).
- Otherwise:** The password **PA2** is amongst the level1 parameters. If enabled, it will be required when accessing the Installer parameters; to enter it, proceed as instructed for password **PA1**.

NOTE: If the password entered is incorrect, the label **PA1/PA2** will be displayed again and the procedure will need to be repeated.

ACCESSO E USO DEI MENU

Resources are organised into 2 menus which are accessed as explained below:

- "Machine Status" menu: press and release the **set** key.
- "Programming" menu: press for at least 5 secs the **set** key.

Either do not press any keys for 15 seconds (time-out) or press the **ⓘ**, key once, to confirm the last value displayed and return to the previous screen.

"MACHINE STATUS" MENU

Access the Machine Status menu by pressing **set** and releasing the key. If no alarms are active, the "SEt" label appears. Use the keys **⏪** and **⏩** to scroll through all the folders in the "Machine Status" menu:

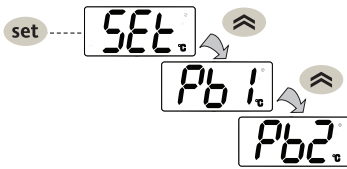

- AL: alarms folder (**visibile solo se ci sono allarmi attivi**);
- SEt: Setpoint setting folder;
- Pb1: probe 1 - Pb1 folder;
- Pb2: probe 2 - Pb2* folder (**EWPlus 971/974 models only**);
* **folder displayed if Pb2 present (H42 = y)**

SETPOINT SETTING:

To display the Setpoint value press the **set** key when the "SEt" label is displayed. The Setpoint value appears on the display. To change the Setpoint value, press the **⏪** and **⏩** keys within 15 seconds. Press **set** to confirm the modification.

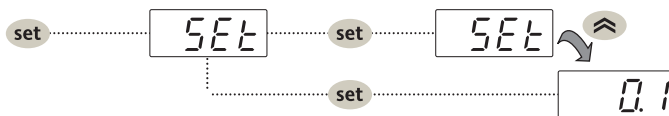

LOCK SETPOINT MODIFICATION: The keypad can be locked by programming the 'LOC' parameter.

With the keypad locked you can still access the 'Machine Status' menu by pressing **set** to display the Set point, but you cannot edit them. To disable the keypad lock, repeat the locking procedure.

DISPLAYING THE PROBES:

When labels Pb1 or Pb2* are present, press the **set** key to view the value measured by the corresponding probe. **N.B.: 1) Pb2 is only present on EWPlus 971/974 models. 2) the value cannot be modified.**

MENU' DI PROGRAMMAZIONE

To access the "Programming" menu, press the **set** key for more than 5 seconds. If specified, an access PASSWORD will be requested: **PA1** for "User" parameters and **PA2** for "Installer" parameters (see "PASSWORD" paragraph).

"User" parameters: When accessed, the display will show the first parameter (e.g. "dF1").

Press **⏪** and **⏩** to scroll through all the parameters on the current level. Select the desired parameter by pressing **set**. Press **⏪** and **⏩** to modify it and **set** to save the changes.

"Installer" parameters: When accessed, the display will show the first folder (e.g. "CP"). Press **⏪** and **⏩** to scroll through the folders on the current level. Select the desired folder using **set**. Press **⏪** and **⏩** to scroll through the parameters in the current folder and select the parameter using **set**. Press **⏪** and **⏩** to modify it and **set** to save the changes.

NOTE: Make sure you switch the instrument off and on again each time the parameter configuration is changed, in order to prevent malfunctioning in the configuration and/or timing in progress.

SET POINT EDIT LOCK

It is possible to disable the keypad on this device. The keypad can be locked by programming the 'LOC' parameter. With the keypad locked you can still access the 'Machine Status' menu by pressing **set** to display the Set point, but you cannot edit them. To disable the keypad lock, repeat the locking procedure.

USING THE UNICARD/COPYCARD

The Unicard/Copycard is connected to the serial port (TTL) and allows rapid programming of the instrument parameters. Access "Installer" parameters by entering **PA2**, scroll through the folders using **⏪** and **⏩** until folder **FPr** appears. Select it using **set**, scroll through the parameters using **⏪** and **⏩**, then select the function using **set** (e.g. **UL**).

- **Upload (UL):** select UL and press **set**. This function uploads the programming parameters from the instrument to the card. If the procedure is a success, "y", will appear on the display, otherwise "n" will appear.
- **Format (Fr):** This command is used to format the Unicard/Copycard, (recommended when using the card for the first time). **IMPORTANT:** the **Fr** parameter deletes all data present. This operation cannot be cancelled.
- **Download:** Connect the Unicard/Copycard when the instrument is switched off. At power-on, data is downloaded from the Unicard/Copycard to the instrument automatically. At the end of the lamp test, the display will show "dLy" if the operation was successful and "dLn" if not.

NOTE:

After downloading, the instrument works with the settings of the new map just downloaded.

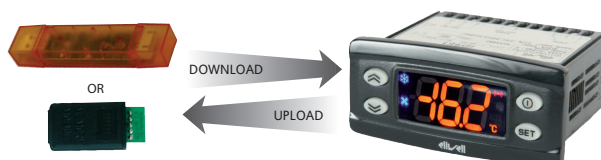

MANUAL DEFROST CYCLE ACTIVATION

To manually activate the defrost cycle, hold down the  key for 5 seconds.

If the defrost conditions are not satisfied:

- parameter OdO \neq 0 (**EWPlus 961/971/974**)
- probe Pb2 temperature is higher than the defrost end temperature (**EWPlus 971/974**)

the display will flash 3 times, to indicate that the operation will not be carried out.

DIAGNOSTICS

Alarms are always indicated by the buzzer (if present) and the alarm icon ().

To switch off the buzzer, press and release any key; the corresponding icon will continue to flash.

NOTE: If alarm exclusion times have been set (see "AL" folder in the parameters table) the alarm will not be signalled.

- **E1:** in the event of cold room probe faulty (Pb1), the indication "E1" will appear on the display.
- **E2:** in the event of defrost probe faulty (Pb2), the indication "E2" will appear on the display (**EWPlus 971/974 models only**).

ALARMS

Label	Fault	Cause	Effects	Remedy
E1	Probe1 faulty (cold room)	<ul style="list-style-type: none"> • measured values are outside operating range • Probe faulty / short-circuited / open 	<ul style="list-style-type: none"> • Display label E1 • Alarm icon permanently on • Disable max/min alarm controller • Compressor operation based on parameters "Ont" and "OFt". 	<ul style="list-style-type: none"> • check probe type (NTC) • check probe wiring • replace probe
E2	Probe2 faulty (defrost) only on EWPlus 971/974	<ul style="list-style-type: none"> • measured values are outside operating range • Probe faulty / short-circuited / open 	<ul style="list-style-type: none"> • Display label E2 • Alarm icon permanently on • The Defrost cycle will end due to Timeout (dEt) • The evaporator fans will work in Duty Cycle mode. 	<ul style="list-style-type: none"> • check probe type (NTC) • check probe wiring • replace probe
AH1	Alarm for HIGH Pb1 temperature	value read by Pb1 > HAL after time of tAO . (see "MAX/MIN TEMPERATURE ALARMS")	<ul style="list-style-type: none"> • Recording of label AH1 in folder AL • No effect on regulation 	<ul style="list-style-type: none"> • Wait until value read by Pb1 returns below HAL-AFd.
AL1	Alarm for LOW Pb1 temperature	value read by Pb1 < LAL after time of tAO . (see "MAX/MIN TEMPERATURE ALARMS")	<ul style="list-style-type: none"> • Recording of label AL1 in folder AL • No effect on regulation 	<ul style="list-style-type: none"> • Wait until value read by Pb1 returns above LAL+AFd.
EA	External alarm	digital input activation (H11 = \pm5)	<ul style="list-style-type: none"> • Recording of label EA in folder AL • Alarm icon permanently on • Regulation locked if rLO = y 	<ul style="list-style-type: none"> • check and remove the external cause which triggered the alarm on the D.I.
OPd	Door open alarm	digital input activation (H11 = \pm4) (for longer than tdO)	<ul style="list-style-type: none"> • Recording of label OPd in folder AL • Alarm icon permanently on • Controller locked 	<ul style="list-style-type: none"> • close the door • delay function defined by OAO
Ad2	end of defrost cycle due to timeout	end of defrost cycle due to timeout rather than due to defrost end temperature being recorded by probe Pb2.	<ul style="list-style-type: none"> • Recording of label Ad2 in folder AL • Alarm icon permanently on 	<ul style="list-style-type: none"> • wait for the next defrost cycle for automatic return

MAX/MIN TEMPERATURE ALARMS

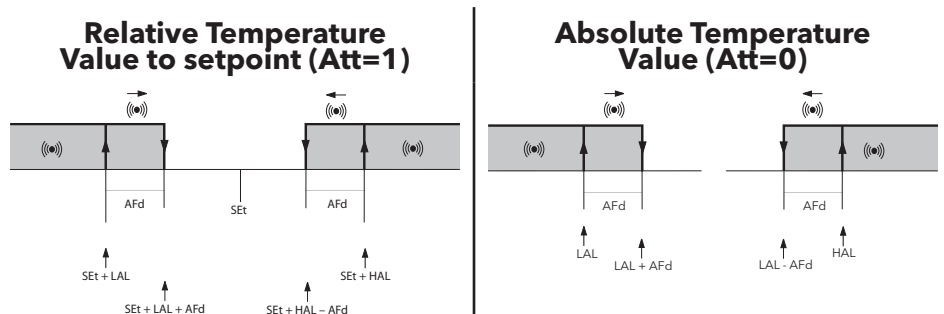

Minimum temperature alarm	Temp. \leq Set + LAL *	Temp. \leq LAL (LAL with sign)
Maximum temperature alarm	Temp. \geq Set + HAL **	Temp. \geq HAL (HAL with sign)
Returning from minimum temperature alarm	Temp. \geq Set + LAL + AFd or \geq Set - LAL + AFd (LAL < 0)	Temp. \geq LAL + AFd
Returning from maximum temperature alarm	Temp. \leq Set + HAL - AFd (HAL > 0)	Temp. \leq HAL - AFd
	* if LAL is negative, Set + LAL < Set **if HAL is negative, Set + HAL < Set	

TECHNICAL DATA (EN 60730-2-9)

Classification:	control device (not safety) to integrate
Mounting:	panel mounting with 71x29 mm (+0.2/-0.1 mm) drilling template
Control type:	1.B
Pollution rating:	2
Material class:	IIIa
Overvoltage category class:	II
Nominal impulsive voltage:	2500V
Temperature:	Operating: -5 ... +55 °C - Storage: -30 ... +85 °C
Power Supply:	230V~ (±10%) 50/60 Hz
Consumption:	4.5W max
Digital Output (relays):	please refer to the device label
Fire resistance class:	D
Software class:	A

NOTE: check the power supply specified on the instrument label; for relay, power supply capacities and PTC probes, contact the Sales Office.

FURTHER INFORMATIONS

Input Characteristics

Display Range:	NTC: -50.0°C ... +110°C; PTC: -55.0°C ... +140°C	(on display with 3 digit + sign)
Accuracy:	Better than 0,5% of full-scale + 1 digit	
Resolution:	0,1 °C	
Buzzer:	YES (it depends from model)	
Analogue Input:	1 NTC input (EWPlus 961) or 2 NTC inputs (EWPlus 971/974)	
Digital Input:	1 voltage-free digital input (D.I.1)	

Output Characteristics

Digital Output:	EWPlus 961:	1 Compressor relay: UL60730	2 Hp (12FLA - 72LRA) max 240V~
	EWPlus 971:	1 Defrost relay: N.A. 8(4)A - N.C. 6(3)A max 250V~	
		1 Compressor relay: UL60730	2 Hp (12FLA - 72LRA) max 240V~
	EWPlus 974:	1 Defrost relay: N.A. 8(4)A - N.C. 6(3)A max 250V~	
		1 Compressor relay: UL60730	1.5 Hp (10FLA - 60LRA) max 240V~
		1 Fans relay: 5(2)A max 250V~	

Mechanical Characteristics

Casing:	PC+ABS UL94 V-0 resin casing, polycarbonate window, thermoplastic resin keys
Dimensions:	front panel 74x32 mm, depth 59 mm (without terminals)
Terminals:	screw/disconnectable terminals for cables with a diameter of 2.5mm ²
Connectors:	TTL for connection of Unicard / Copy Card
Humidity:	Operating / Storage: 10...90 % RH (non-condensing)

Regulations

Electromagnetic compatibility:	The device conforms to Directive 2004/108/EC
Safety:	The device conforms to Directive 2006/95/EC
Food Safety:	The device complies with standard EN13485 as follows: <ul style="list-style-type: none">- suitable for storage- application: air- climate range A- measurement class 1 in the range from -25°C to 15°C (exclusively using Eliwell NTC probes)

NOTE: The technical specifications given in this document regarding measurement (range, accuracy, resolution, etc.) refer to the instrument and not to any accessories provided, such as the probes. This means, for example, that the error introduced by the probe must be added to the typical error of the instrument.

ELECTRICAL CONNECTIONS

Attention! Make sure the machine is switched off before working on the electrical connections.

The instrument is equipped with screw or disconnectable terminal blocks for connecting electrical cables with a max. diameter of 2.5 mm² (one wire per terminal for power connections): for the terminal ratings, see the label on the instrument. Do not exceed the maximum permissible current; in case of higher loads, use a suitably rated contactor. Make sure the power supply voltage complies with that required by the instrument. Probes have no connection polarity and can be extended using a normal bipolar cable (note that the extension of the probes influences the electromagnetic compatibility - EMC - of the instrument: take great care with the wiring). Probe cables, power supply cables and the TTL serial cable should be routed separately from power cables.

TABLE OF "INSTALLER" MENU PARAMETERS

PAR.	DESCRIPTION	RANGE	M.U.	EWPlus 961	EWPlus 971	EWPlus 974	LEVEL	
SEt	Temperature control SEtpoint. The SEtpoint is visible from the "machine status" menu only.	LSE ... HSE	°C/°F	0.0	0.0	0.0		
COMPRESSOR ('CP' folder)								
dF1	diFFerential. Compressor relay activation differential. N.B.: diF cannot be equal to 0.	0.1 ... 30.0	°C/°F	2.0	2.0	2.0	1&2	
HSE	Maximum value that can be assigned to the Setpoint. N.B.: The two Setpoints are interdependent: HSE cannot be less than LSE and vice-versa.	LSE ... 320	°C/°F	99.0	99.0	99.0	1&2	
LSE	Minimum value that can be assigned to the Setpoint. N.B.: The two Setpoints are interdependent: LSE cannot be higher than HSE and vice-versa.	-67.0 ... HSE	°C/°F	-50.0	-50.0	-50.0	1&2	
HC	The regulator will go to HOT operating mode ('H') or COLD operating mode ('C')	C/F	flag	C			2	
Ont	Controller ON time for faulty probe. - if Ont = 1 and OFt = 0, the compressor remains ON - if Ont > 0 and OFt > 0, it runs in duty cycle mode.	0 ... 250	min	0	0	0	2	
OFt	Controller OFF time for faulty probe. - if OFt = 1 and Ont = 0, the compressor remains OFF - if Ont > 0 and OFt > 0, it runs in duty cycle mode.	0 ... 250	min	1	1	1	2	
dOn	Compressor relay activation delay after request.	0 ... 250	secs	0	0	0	2	
dOF	Delay after switching off and subsequent activation.	0 ... 250	min	0	0	0	2	
dbi	Delay between two consecutive compressor activations.	0 ... 250	min	0	0	0	2	
OdO (!)	Delay in activating outputs after the instrument is switched on or after a power failure. 0 = not active.	0 ... 250	min	0	0	0	2	
DEFROST ('DEF' folder)								
dty	Type of defrost. 0 = electric defrost - compressor OFF during defrost cycle 1 = cycle inversion defrost (hot gas) - compressor ON during defrost cycle 2 = 'Free': defrosting independently of compressor	0/1/2	num		0	0	1&2	
dit	Interval between the start of two consecutive defrost cycles. 0 = function disabled (defrosting NEVER performed)	0 ... 250	hours	6	6	6	1&2	
dCt	Selects the count mode for the defrost interval: 0 = compressor hours of operation (DIGIFROST® method); Defrost active ONLY when the compressor is on. NOTE: compressor operation time is counted separately from the evaporator probe (count active also when evaporator probe missing or faulty). 1 = appliance running hours = the defrost count is always active when the machine is on and starts at each power-on; 2 = compressor stop Every time the compressor stops, a defrost cycle is performed according to parameter dTY; 3 = temperature.	0/1/2/3	num	1	1	1	2	
dOH	Defrost start delay time after request.	0 ... 59	min	0	0	0	2	
dEt	Defrost time-out; determines the maximum defrost duration.	1 ... 250	min	30	30	30	1&2	
dS1	Defrost end temperature (determined by the evaporator probe).	-67.0 ... 320	°C/°F		8.0	8.0	1&2	
dPO	Determines whether the instrument must enter defrost mode (if the temperature measured by the evaporator allows this operation). n = no; y = yes.	n/y	flag	n	n	n	2	
FANS ('FAn' folder)								
Fpt	Characterizes the "FSt" parameter that can be expressed or as an absolute temperature value or as a value related to Setpoint. 0 = absolute; 1 = relative.	0/1	flag			0	2	
FSt	Fan lock temperature; if Pb2 > FSt , the fans are stopped. The value is either positive or negative and, depending on parameter Fpt , can be either the absolute temperature or the temperature relative to the Setpoint.	-67.0 ... 320	°C/°F			50.0	1&2	
FAd	Fan starting differential (see parameter FSt).	1.0 ... 50.0	°C/°F			2.0	2	
Fdt	Delay time in activating fans after a defrost operation.	0 ... 250	min			0	1&2	
dt	drainage time. Dripping time.	0 ... 250	min		0	0	1&2	
dFd	Allows to select the evaporator fans exclusion during defrost. y = yes; n = no.	n/y	flag			y	1&2	
FCO	Evaporator fans operating mode. The state of the fans will be:							
		DAY		NIGHT				
		H42	FCO	COMPRESSOR ON	COMPRESSOR OFF	COMPRESSOR ON	COMPRESSOR OFF	
	H42 = y	0		Regulated by Pb2	OFF	Regulated by Pb2	OFF	
		1		Regulated by Pb2	Regulated by Pb2	Regulated by Pb2	Regulated by Pb2	
		2		Regulated by Pb2	Dutycycle Day	Regulated by Pb2	Dutycycle Night	
	H42 = n	3		Dutycycle Day	Dutycycle Day	Dutycycle Night	Dutycycle Night	
		0		ON	OFF	ON	OFF	
		1		ON	Dutycycle Day	ON	Dutycycle Night	
		2		ON	Dutycycle Day	ON	Dutycycle Night	
3		Dutycycle Day	Dutycycle Day	Dutycycle Night	Dutycycle Night			
Dutycycle Day: controlled by means of parameters " Fon " and " FoF ". Dutycycle Night: controlled by means of parameters " Fnn " and " FnF ".								
ALARMS ('AL' folder)								
Att	Parameters HAL and LAL intended as the absolute temperature value or differential in relation to the setpoint. 0 = absolute value; 1 = relative value.	0/1	num	1	1	1	2	
AFd	Alarm differential.	1.0 ... 50.0	°C/°F	2.0	2.0	2.0	2	

PAR.	DESCRIPTION	RANGE	M.U.	EWPlus 961	EWPlus 971	EWPlus 974	LEVEL
HAL (!)	Maximum temperature alarm. Temperature value (intended either as distance from Setpoint or as an absolute value based on Att) which, if exceeded in an upward direction, triggers the activation of the alarm signal. See "Max/Min Temperature Alarms" .	LAL ... 320	°C/°F	50.0	50.0	50.0	1&2
LAL (!)	Minimum temperature alarm. Temperature value (intended as distance from the set point or as an absolute value based on Att) which, when exceeded downwards, triggers the activation of the alarm signal. See "Max/Min Temperature Alarms" .	-67.0 ... HAL	°C/°F	-50.0	-50.0	-50.0	1&2
PAO (!)	Alarm exclusion time after instrument switch on, after a power failure. This parameter refers to high/low temperature alarms only.	0 ... 10	ore	0	0	0	2
dAO	Temperature alarm exclusion time after defrost.	0 ... 999	min	0	0	0	2
OA0	Alarm signaling delay after digital input disabling (door close). This parameter refers to high/low temperature alarms only.	0 ... 10	ore	0	0	0	2
tdO	Alarm activation delay time open door.	0 ... 250	min	0	0	0	2
tAO	Temperature alarm signal delay time. This parameter refers to high/low temperature alarms only.	0 ... 250	min	0	0	0	1&2
dAt	Alarm for defrosting ended due to time out. n = alarm deactivated; y = alarm activated.	n/y	flag		n	n	2
rLO	External alarm locks controllers. n = does not lock; y = locks.	n/y	flag	n	n	n	2
LIGHTS & DIGITAL INPUTS ('Lit' folder)							
dOd	Enable utility switch-off on activation of door switch. 0 = disabled; 1 = disables fans; 2 = disables compressor; 3 = disables fans and compressor.	0/1/2/3	num	0	0	0	2
dAd	Activation delay for digital input.	0 ... 255	min	0	0	0	2
ENERGY SAVING ('EnS' folder)							
OSP	Offset on setpoint.	-30.0 ... 30.0	°C/°F	1.0	1.0	1.0	2
DISPLAY ('dis' folder)							
LOC	LOCK. Setpoint change shutdown. There is still the possibility to enter into parameters programming and modify these, including the status of this parameter to permit keyboard shutdown. n = no; y = yes.	n/y	flag	n	n	n	1&2
PS1	PASsword 1. When enabled (PS1 ≠ 0), this is the access key to level 1 parameters (User).	0...250	num	0	0	0	1&2
PS2	PASsword 2. When enabled (PS2 ≠ 0), this is the access key to level 2 parameters (Installer).	0...250	num	15	15	15	2
ndt	Display with decimal point. n = no (integers only); y = yes.	n/y	flag	y	y	y	2
CA1	Calibration 1. Positive or negative temperature value added to the value read by Pb1 . This sum is used both for the temperature displayed and for regulation.	-12.0 ... 12.0	°C/°F	0.0	0.0	0.0	1&2
CA2	Calibration 2. Positive or negative temperature value added to the value read by Pb2 . This sum is used both for the temperature displayed and for regulation.	-12.0 ... 12.0	°C/°F		0.0	0.0	1&2
ddl	Display mode during defrost. 0 = display the temperature read by Pb1 ; 1 = locks the reading on the temperature value read by Pb1 when defrosting starts, and until the next time the SEt value is reached; 2 = displays the label deF during defrosting, and until the next time the SEt value is reached.	0/1/2	num	1	1	1	1&2
dro	Select °C or °F for displaying the temperature read by probes. 0 = °C, 1 = °F. NOTE: switching between °C and °F or vice-versa DOES NOT modify the SEt, diF values, etc. (e.g. Setpoint=10°C becomes 10°F).	0/1	num	0	0	0	2
ddd	Selection of type of value to be displayed. 0 = Setpoint; 1 = probe Pb1; 2 = probe Pb2; 3 = not used; 4 = Display "ON"; 5 = not used.	0 ... 5	num	1	1	1	2
dde	Selection of value to display on ECHO (ECPlus). 0 = Disabled (not present); 1 = probe Pb1; 2 = probe Pb2; 3 = not used; 4 = Setpoint.	0 ... 4	num	1	1	1	2
CONFIGURATION ('CnF' folder) - NOTE: the instrument must be switched off and then on again each time folder CnF parameter configuration is modified to prevent any malfunction of the configuration and/or current timer operations.							
H08	Stand-by operating mode. 0 = display switch off; the loads are active and the device reactivates the display to signal any alarms; 1 = display switch off, loads and alarms stopped; 2 = display with OFF label, loads and alarms stopped.	0/1/2	num	2	2	2	2
H11	Configuration of digital input 1/polarity (D.I.1). 0 = disabled; ±1 = defrost; ±2 = reduced SET; ±3 = AUX; ±4 = door switch; ±5 = external alarm; ±6 = stand-by (ON-OFF); ±7 = not used; ±8 = deep cooling; ±9 = not used; ±10 = not used. NOTE: - the '+' sign indicates that the input is active if the contact is closed - the '-' sign indicates that the input is active if the contact is open	-10 ... 10	num	0	0	0	2
H21	Configurability of digital output 1 (A). 0 = disabled; 1 = compressor; 2 = defrost; 3 = fans; 4 = alarm; 5 = AUX; 6 = Stand-by; 7 = not used; 8 = condenser fan change rotation; 9 = Heater; 10 = defrost on 2nd evaporator; 11 = 2nd compressor.	0 ... 11	num	1	1	1	2
H22	Configurability of digital output 2 (B). Same as H21.	0 ... 11	num		2	2	2
H23	Configurability of digital output 3 (C). Same as H21.	0 ... 11	num			3	2
H32	Configurability of DOWN key. 0 = disabled; 1 = defrost; 2 = AUX; 3 = reduced SET; 4 = Stand-by; 5 = deep cooling; 6 = not used.	0 ... 6	num	0	0	0	2
H42	Evaporator probe present (Pb2). n = not present; y = present.	n/y	flag		y	y	1&2
reL	release firmware. Device version: read-only parameter.	/	/	/	/	/	1&2
tAb	tAble of parameters. Reserved: read-only parameter.	/	/	/	/	/	1&2

PAR.	DESCRIPTION	RANGE	M.U.	EWPlus 961	EWPlus 971	EWPlus 974	LEVEL
COPY CARD ('Fpr' folder)							
UL	Upload. Programming parameter transfer from instrument to Copy Card.	/	/	/	/	/	
Fr	Format Copy Card. Erase all data contained in the Copy Card ATTENTION: If parameter "Fr" is used, the data entered will be permanently lost. This operation cannot be cancelled.	/	/	/	/	/	

LIABILITY AND RESIDUAL RISKS

ELIWELL CONTROLS SRL declines any liability for damage due to:

- installation/uses different from those specified and, in particular, not complying with the safety regulations and/or instructions given in this document;
- use on panels that do not provide adequate protection against electric shocks, water or dust when assembled;
- use on panels allowing access to dangerous parts without the use of tools;
- tampering with and/or modifying the product;
- installation/use on panels not complying with current standards and regulations.

DISCLAIMER

This document is the exclusive property of ELIWELL CONTROLS SRL and may not be reproduced or circulated unless expressly authorised by ELIWELL CONTROLS SRL itself. Every care has been taken in preparing this document; nevertheless ELIWELL CONTROLS SRL cannot accept liability for any damage resulting from its use.

The same applies to any person or company involved in preparing and editing this document.

ELIWELL CONTROLS SRL reserves the right to make aesthetic or functional changes at any time without notice.

CONDITIONS OF USE

Permitted use

For safety reasons, the instrument must be installed and used according to the instructions supplied and, in particular, parts under dangerous voltages must not be accessible in normal conditions. The device must be adequately protected from water and dust with regard to its application, and must only be accessible using tools (except for the front panel).

The device is suitable for use in household refrigeration appliances and/or similar equipment and has been tested for safety aspects in accordance with the harmonised European reference standards.

Improper use

Any use other than that expressly permitted is prohibited. The relay contacts provided are of a functional type and subject to failure: any protection devices required by product standards, or suggested by common sense for obvious safety requirements, must be installed externally to the instrument.

eliwell

Eliwell Controls s.r.l.

Via dell'Industria, 15 • Z.I. Paludi
32010 Pieve d'Alpago (BL) ITALY
Telephone: +39 0437 986 111
Fax: +39 0437 989 066

www.eliwell.com

Technical Customer Support:

Technical helpline: +39 0437 986 300
E-mail: techsuppeliwell@invensys.com

Sales:

Telephone: +39 0437 986 100 (Italy)
+39 0437 986 200 (other countries)
E-mail: saleseliwell@invensys.com



ISO 9001

